

S1C17 Manual errata

ITEM:			
Object manuals	Document codes	Items	Pages
S5U1C17001H User Manual (ICDmini Ver1.0 and 1.1)	411153602	4.1.1 Target Interface Connector	9
Same as above	Same as above	8.3 Notes on Use of S5U1C17001H	21

(Error)

4.1.1 Target Interface Connector

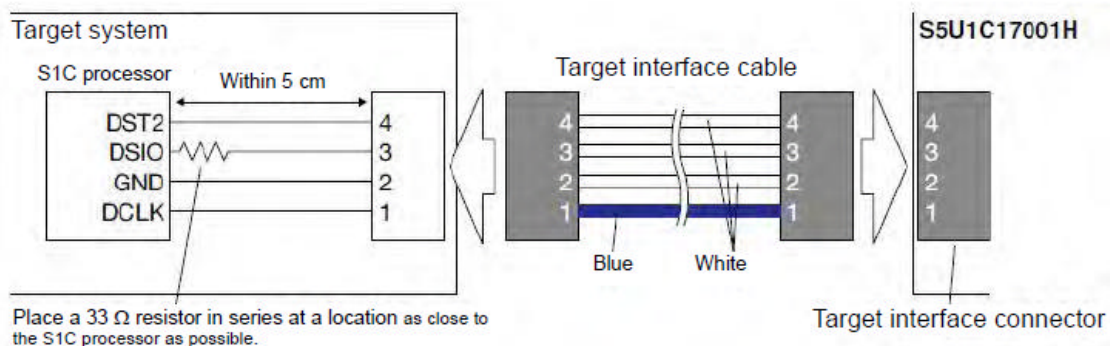

Figure 4.1.1.1 Connecting the Target System

Notes:

- When wiring the S1C processor to the target connector for connecting the S5U1C17001H, insert a 33ohm resistor in series between the S1C processor DSIO pin and the connector. This resistor must be placed as close to the S1C processor as possible. Although the system can operate without this 33ohm resistor, we recommend inserting this resistor to prevent malfunctions. The other pins are connected directly. A low-level input to the DSIO pin issues a forced break to set the S1C processor into debug mode. Although this signal is pulled up through about 100k ohm internally, when not debugging, we recommend either removing the 33ohm resistor to reduce noise and other problems or pulling this line up to the VDD level.

8.3 Notes on Use of S5U1C17001H

Wiring between the S1C processor and target connector

When wiring the S1C processor to the target system connector for connecting the S5U1C17001H, insert a 33ohm resistor in series between the S1C processor DSIO pin and the connector. This resistor must be placed as close to the S1C processor as possible. If the reset line is not connected, the system can be operated without this 33ohm resistor. However, we recommend inserting this resistor to prevent malfunctions. The other pins are connected directly. The total length of the line must be under 5 cm. A low-level input to the DSIO pin issues a forced break to set the S1C processor into debug mode. Although this signal is pulled up through about 100k ohm internally, when not debugging, we recommend either removing the 33ohm resistor to reduce noise and other problems or pulling this line up to the VDD level.

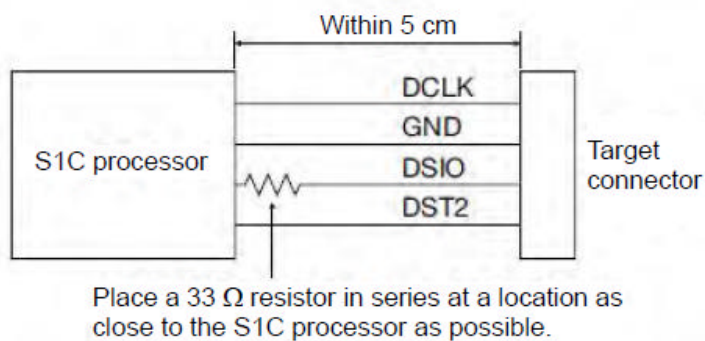

Figure 8.3.1 Wiring between S1C Processor and Target Connector

(Correct)

4.1.1 Target Interface Connector

Figure 4.1.1.1 Connecting the Target System

Notes:

- Please refer to a technical manual of each model for the connection method with the target system.

8.3 Notes on Use of S5U1C17001H

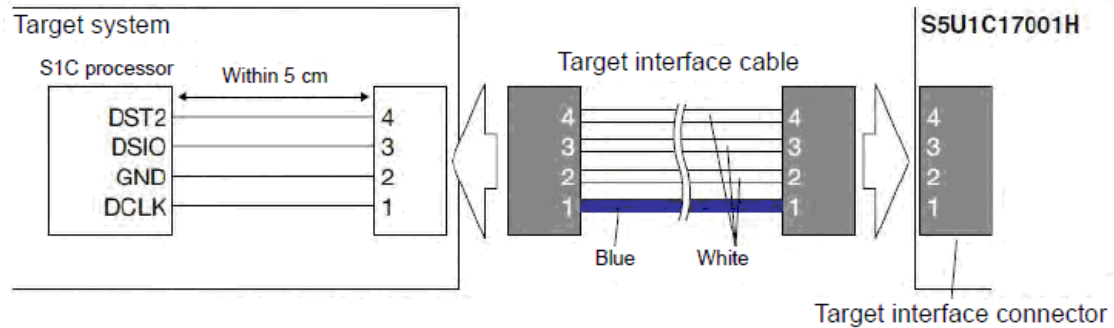
Wiring between the S1C processor and target connector

Please refer to a technical manual of each model for the connection method with the target system. Moreover, The total length of the line must be under 5 cm.

(Delete Figure 8.3.1)

S1C17 Manual errata

ITEM:			
Object manuals	Document codes	Items	Pages
S5U1C17001H User Manual (ICDmini Ver1.0 and 1.1)	411153602	8.3 Notes on Use of S5U1C17001H	33
(Error) There is no description.			
(Correct) <p>About how to put this product Please use this product with the rubber foot below.</p> <p>About the accessory Please use the USB cable attached to this product.</p> <p>About the using environment requirements Please use this product indoors.</p>			

S1C17 Manual errata

ITEM:			
Object manuals	Document codes	Items	Pages
S5U1C17001H User Manual	411153602	7. Firmware Update	17
(Error) Added.			
(Correct) (5) Check the current firmware version, and enter the following commands if you need to update the firmware. (gdb) c17 fwe 0 (gdb) c17 fwe 1 (gdb) c17 firmupdate <i>path</i> \ <i>filename</i> .saf <i>path</i> : Path of the new firmware <i>filename.saf</i> : File name of the new firmware After entering the commands, the following will be displayed. (gdb) c17 fwe 0 Erase flash data ...done (gdb) c17 fwe 1 Erase flash erase/write program ...done (gdb) c17 firmupdate <i>path</i> \ <i>filename</i> .saf Erase flash data ...done Load flash datadone ICD firmware update ...done Please quit gdb, and power off ICD when LED2/LED3/LED4 is green. (LED is green in the case of SVT17701). This procedure may take about 15 minutes. While updating the firmware, DO NOT reset S5U1C17001H or turn off the power. Otherwise S5U1C17001H may not start up.			

S1C17 Manual errata

ITEM:			
Object manuals	Document codes	Items	Pages
S5U1C17001H User Manual (ICDmini Ver1.0 and 1.1)	411153602	4.1.2.1 Target reset signal output (TARGET RST OUT)	10
<p>(Error) Target reset signal output (TARGET RST OUT)</p> <p>When using the TARGET RST OUT output, a reset circuit as shown in the figure below is recommended.</p> <div style="text-align: center; margin: 10px 0;"> </div> <p style="text-align: center;">Figure 4.1.2.1 Example of Target Reset Circuit</p>			

(Correct) **Target reset signal output (TARGET RST OUT)**

The TARGET RST OUT terminal of S5U1C17001H is the following circuits.

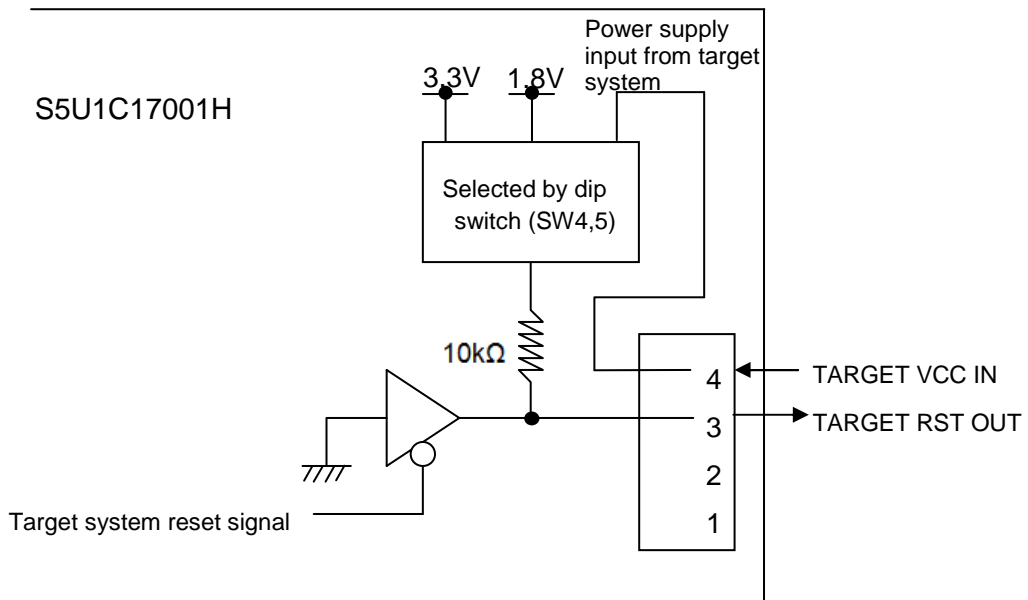

Figure 4.1. 2.1 Target reset terminal output circuit

The reset pulse is the following waveforms. Please note that the rising up waveform changes by the load situation of the target board.

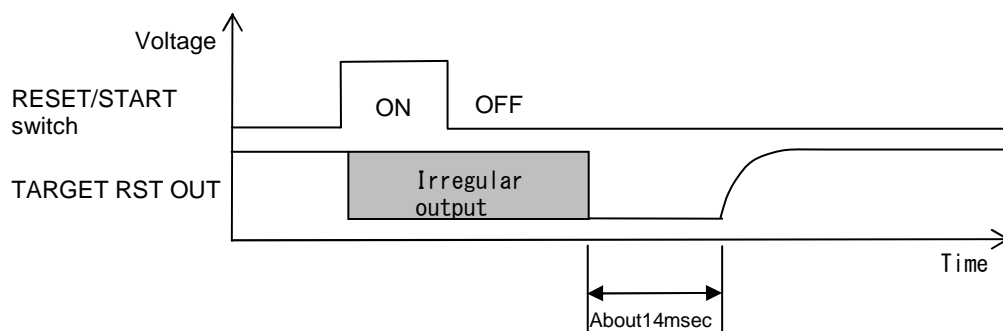

Figure 4.1.2.2(a) Reset terminal output waveform

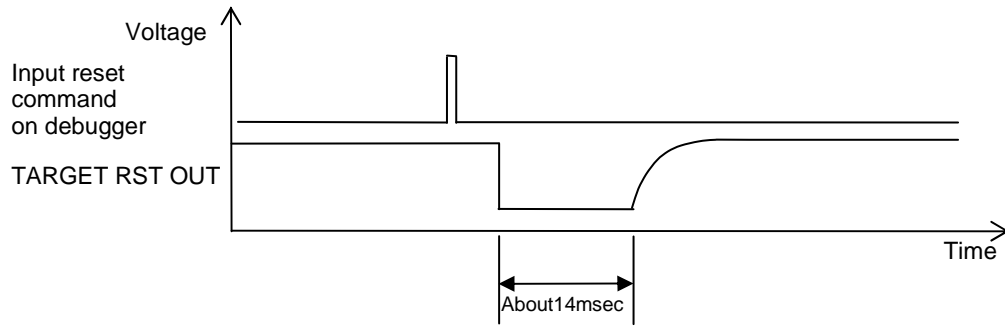

Figure 4.1.2.2(b) Reset terminal output waveform