

## Low ESR, 1.6 x 1.0 mm size

### 32.768 kHz Crystal unit: FC1610BN

#### Features

- Package size: 1.6 x 1.0 mm, t = 0.5 mm Max.
- Nominal frequency range: 32.768 kHz
- Frequency tolerance:  $\pm 20 \times 10^{-6}$  (+25 °C)
- Operating temperature: -40 °C to +105 °C
- ESR: 45 k $\Omega$  Typ. (+25 °C)  
60 k $\Omega$  Max. (-40 °C to +85 °C)  
70 k $\Omega$  Max. (-40 °C to +105 °C)

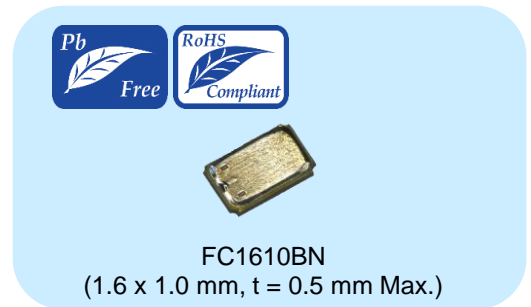

#### Applications

- Wearable products
- MCUs for sub-clock
- Wireless modules for sub-clock
- FA equipment

#### Description

FC1610BN is a small size (1.6 mm x 1.0 mm) and low ESR (70 k $\Omega$ ) 32.768 kHz crystal unit. Ideal for IoT (BLE, LPWA, etc.) sleep clocks that require small size and low power, clocks for wearable devices, sub clocks for microcomputers, etc. The operating temperature range is supported up to +105°C.

Epson is a leading supplier of kHz-band crystal units and offers a lineup of oscillators with built-in oscillator circuit ICs and real-time clock modules with built-in real-time clock ICs, in addition to crystal units. Epson is committed to providing the lowest power solution for our customers.

#### Outline Drawing and Terminal Assignment

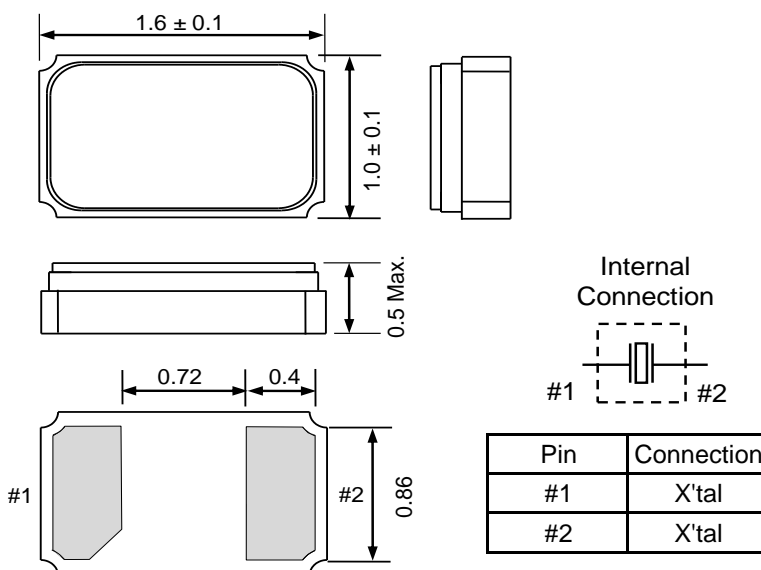

## [ 1 ] Product Number / Product Name

(1-1) Product Number

X1A000191xxxx18 (Please contact Epson for details)

(1-2) Product Name (Standard Form)

FC1610BN 32.768000kHz 12.5 +20.0-20.0

a b c d

a: Model b: Frequency c: Load capacitance (pF) d: Frequency tolerance ( $\times 10^{-6}$ , +25 °C)

## [ 2 ] Absolute Maximum Ratings

Item	Symbol	Rating value			Unit	Note
		Min.	Typ.	Max.		
Storage temperature range	T_stg	-55	-	+125	°C	
Maximum level of drive	GL	-	-	0.5	$\mu$ W	

## [ 3 ] Operating Conditions

Item	Symbol	Rating value			Unit	Note
		Min.	Typ.	Max.		
Operating temperature range	T_use	-40	-	+105	°C	
Level of drive	DL	0.01	0.1	0.5	$\mu$ W	
Load capacitance	CL	7.0, 9.0, 12.5			pF	Please contact us for other CL values

## [ 4 ] Static Characteristics

Item	Symbol	Specifications	Unit	Condition / Remarks
Nominal frequency range	f_nom	32.768	kHz	
Frequency tolerance	f_tol	$\pm 20$	$\times 10^{-6}$	T_use = +25 °C $\pm$ 3 °C DL = 0.1 $\mu$ W Does not include frequency aging
Turnover temperature	Ti	+25 $\pm$ 5	°C	
Parabolic coefficient	B	-0.04 Max.	$\times 10^{-6} / ^\circ\text{C}^2$	
Motional resistance(ESR)	R1	45 Typ. (+25 °C)	k $\Omega$	Measuring instrument: Keysight 4294A DL = 0.5 $\mu$ W
		60 Max. (-40 °C to +85 °C)		
		70 Max. (-40 °C to +105 °C)		
Motional capacitance	C1	7.9 Typ.	fF	
Shunt capacitance	C0	1.5 Typ.	pF	
Isolation resistance	IR	200 Min.	M $\Omega$	
Frequency aging	f_age	$\pm 3$	$\times 10^{-6}$	T_use = +25 °C $\pm$ 3 °C, First year, DL = 0.1 $\mu$ W

[ 5 ] Frequency vs. Temperature Characteristics

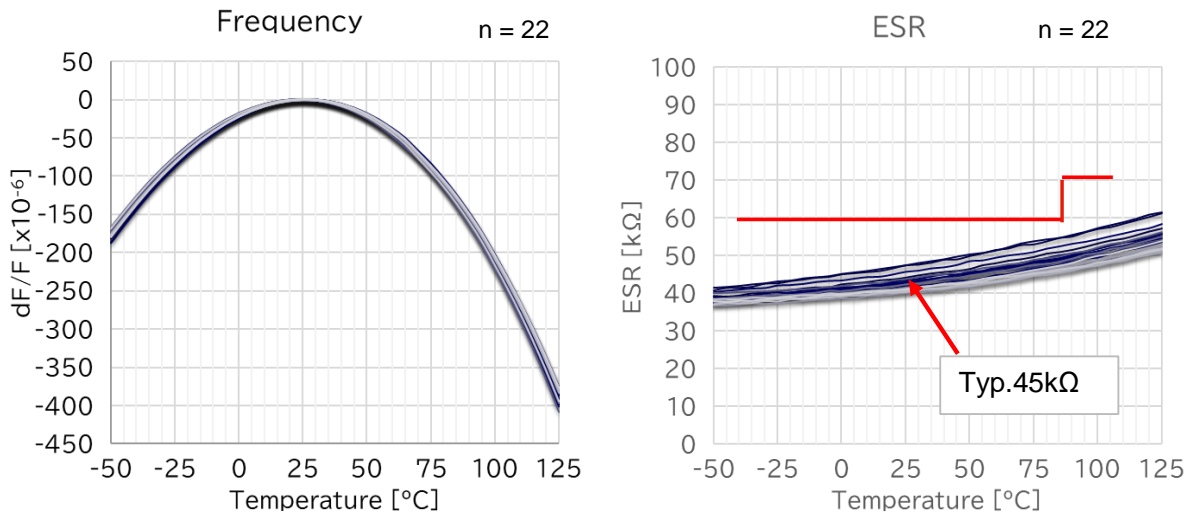

[ 6 ] Marking Description

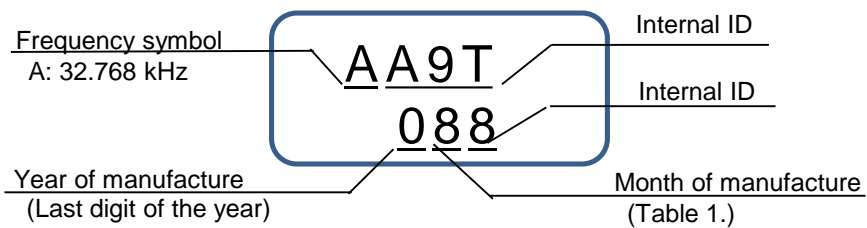
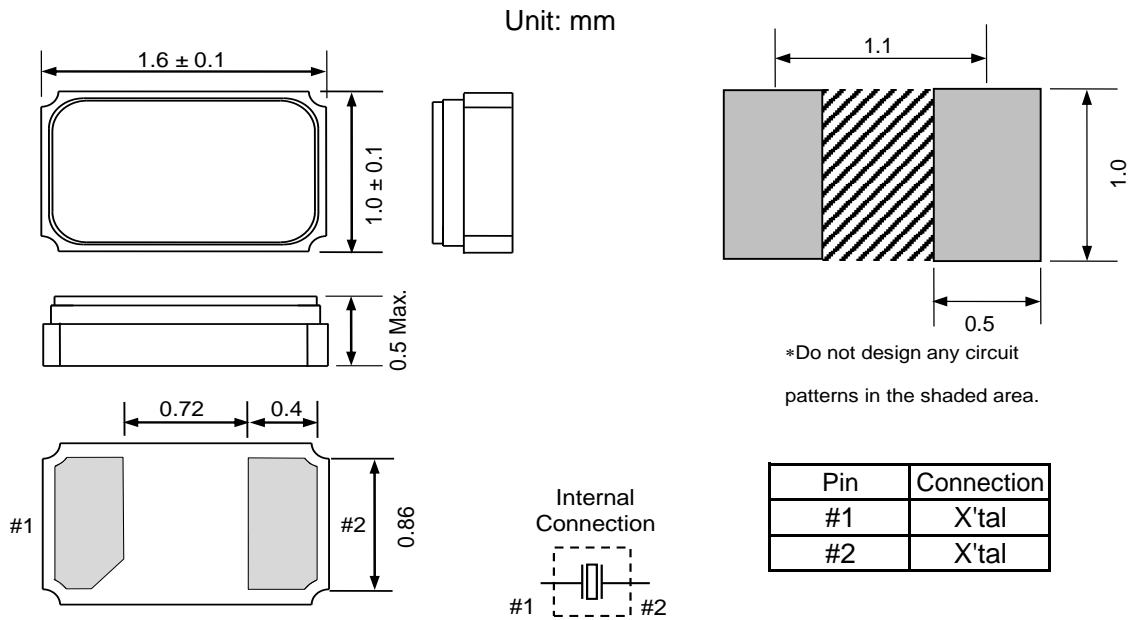

Table 1. Month of manufacture

Month	Jan	Feb	Mar	Apr	May	Jun	Jul	Aug	Sep	Oct	Nov	Dec
Code	1	2	3	4	5	6	7	8	9	X	Y	Z

[ 7 ] Outline Drawing and Recommended Footprint



Reference weight: Typ.2.6 mg

Terminal coating: Au plating

[ 8 ] Moisture Sensitivity Level

Parameter	Specification	Conditions
MSL	LEVEL1	IPC/JEDEC J-STD-020D.1

[ 9 ] Reflow Profile (IPC/JEDEC J-STD-020D.1)

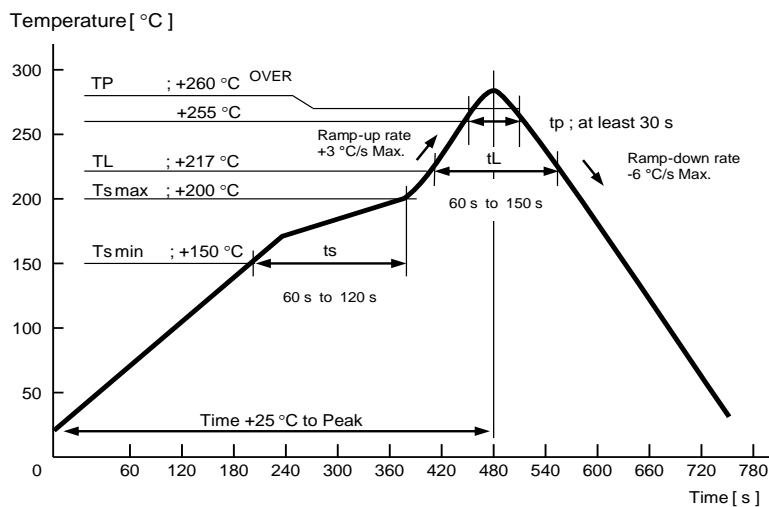

## [ 10 ] Packing Information

## (1) Packing Quantity

The last two digits of the Product Number (X1A000191xxxx18) are a code that defines the packing quantity.  
The standard is "18" for a 5 000 pcs/Reel.

## (2) Taping Specification

Compliant to EIA-481, IEC 60286

## (2-1) Tape Dimensions

Carrier Tape Material : PS (Polystyrene)

Top Tape Material : PET (Polyethylene Terephthalate) +PE (Polyethylene)

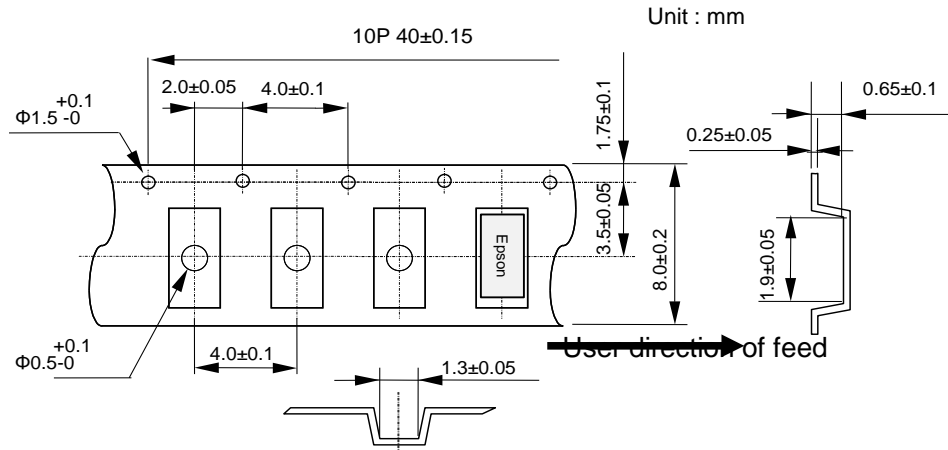

## (2-2) Reel Dimensions

Center Material : PS (Polystyrene)

Reel Material : PS (Polystyrene)

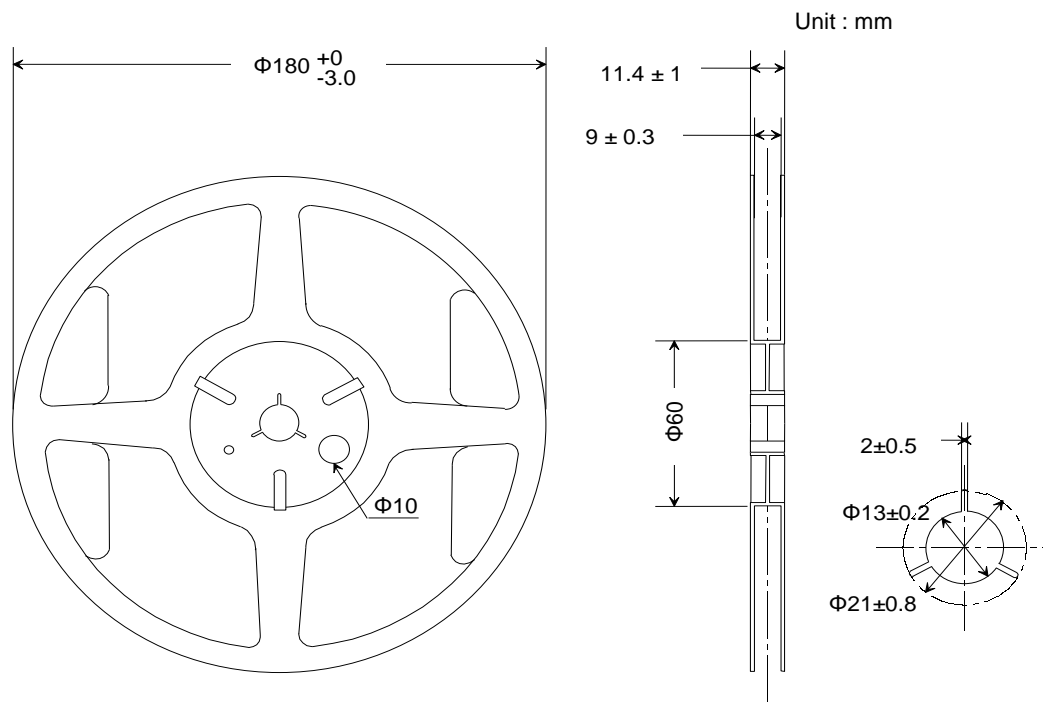

## [ 11 ] Handling Precautions

Please review the "Handling Precautions" on our website for proper handling and behavior to ensure the performance of your equipment/product.  
(<https://www5.epsondevice.com/en/information/#precaution>) In addition to the "Handling Precautions" on the website, please also pay attention to the following to avoid deterioration of product performance.

1. Max three (3) times reflow is allowed.  
In case of rework by soldering iron, its condition should be +350 °C max. + within 5 sec.
2. Applying excessive shock or vibration to the crystal unit may causes deterioration damage.  
The product may be damaged depends on the condition such as shock in assembly machine.  
Please check if your condition is safe in advance.  
And in case of assembly condition change, please check it again in advance.
3. Shortest line pattern on PCB is recommended.  
Too long line on PCB may causes abnormal oscillation.
4. Failures covered by free warranty period are limited to the cases where the product is used under the usage and environment described in the specifications. In addition, products that have been opened (including partially opened, modified, or intended to be opened) are not covered. In order to ensure frequency accuracy and prevent moisture condensation due to sudden temperature changes, it is recommended to store and use in normal room temperature and humidity.  
If the product is stored for a long period (one year or more), please check solderability of the terminals before use.
5. Ultrasonic cleaning may cause resonant damage of the crystal unit depend on its condition.  
Since we are unable to specify the conditions (type of cleaning unit, power, time, condition inside the bath, etc.) at your company, we cannot guarantee the performance of the product when it is cleaned by ultrasonic cleaner.
6. Condensation on oscillator circuit board may causes frequency shift or oscillation stop.  
Please use the product under the condition there is no condensation.
7. If excessive drive level is applied to the crystal unit, it may cause performance deterioration and damages. Please design appropriate drive level on the circuit.
8. Characteristics differences between our measurement and your company's measurement may occur depending on measurement method and conditions. Please check it thoroughly before use.
9. Do not place signal lines, power lines, or GND lines in mounting area of the product, its inner layer, or its back side. In order to avoid malfunction due to induction of other signal lines, please do not place signal lines near the product. It may affect product characteristics.
10. If there is no margin in negative resistance of the oscillator circuit, the crystal unit may not oscillate or may take a long time to oscillate. Therefore, negative resistance in the oscillator circuit should be at least five times of the crystal unit's equivalent series resistance. Please follow this circuit design rule.
11. Aging specifications are estimated value of frequency shift from reliability test results. It does not mean to guarantee product lifecycle.
12. If customer wants to use our product contrary to this caution and advice, please use it at your own risk.

<How to check the negative resistance>

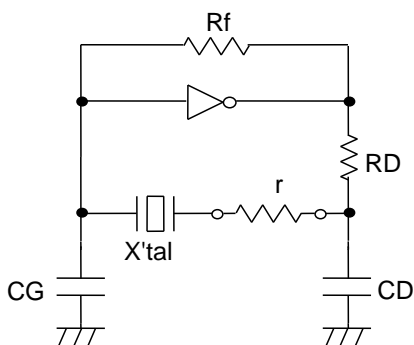

- 1) Insert a pure resistance " r " in series with the crystal oscillator.
- 2) Adjust " r " to find the maximum " r " value that starts oscillation
- 3) Look at the value of " r " in the oscillation state of 2).

Negative resistance of the circuit  $|-R| =$

$r +$  crystal unit series resistance value R1

Guideline for negative resistance  $|-R|$ :

$|-R| > R1 \text{ Max. } \times 5$

## PROMOTION OF ENVIRONMENTAL MANAGEMENT SYSTEM CONFORMING TO INTERNATIONAL STANDARDS

At Seiko Epson, all environmental initiatives operate under the Plan-Do-Check-Action (PDCA) cycle designed to achieve continuous improvements. The environmental management system (EMS) operates under the ISO 14001 environmental management standard.

All of our major manufacturing and non-manufacturing sites, in Japan and overseas, completed the acquisition of ISO 14001 certification.



ISO 14000 is an international standard for environmental management that was established by the International Standards Organization in 1996 against the background of growing concern regarding global warming, destruction of the ozone layer, and global deforestation.

## WORKING FOR HIGH QUALITY

In order provide high quality and reliable products and services than meet customer needs, Seiko Epson made early efforts towards obtaining ISO9000 series certification and has acquired ISO9001 for all business establishments in Japan and abroad. We have also acquired IATF 16949 certification that is requested strongly by major manufacturers as standard.

IATF 16949 is the international standard that added the sector-specific supplemental requirements for automotive industry based on ISO9001.

### ■ Explanation of marks used in this datasheet

	<p>●Pb free.</p>
	<p>●Complies with EU RoHS directive. *About the products without the Pb-free mark. Contains Pb in products exempted by EU RoHS directive (Contains Pb in sealing glass, high melting temperature type solder or other)</p>

NOTICE: PLEASE READ CAREFULLY BELOW BEFORE THE USE OF THIS DOCUMENT ©Seiko Epson Corporation 2020

- The content of this document is subject to change without notice.** Before purchasing or using Epson products, please contact with sales representative of Seiko Epson Corporation ("Epson") for the latest information and be always sure to check the latest information published on Epson's official web sites and resources.
- This document may not be copied, reproduced, or used for any other purposes, in whole or in part, without Epson's prior consent.
- Information provided in this document including, but not limited to application circuits, programs and usage, is for reference purpose only. Epson makes no guarantees against any infringements or damages to any third parties' intellectual property rights or any other rights resulting from the information. This document does not grant you any licenses, any intellectual property rights or any other rights with respect to Epson products owned by Epson or any third parties.
- Using Epson products, you shall be responsible for safe design in your products; that is, your hardware, software, and/or systems shall be designed enough to prevent any critical harm or damages to life, health or property, even if any malfunction or failure might be caused by Epson products. In designing your products with Epson products, please be sure to check and comply with the latest information regarding Epson products (including, but not limited to this document, specifications, data sheets, manuals, and Epson's web site). Using technical contents such as product data, graphic and chart, and technical information, including programs, algorithms and application circuit examples under this document, you shall evaluate your products thoroughly both in stand-alone basis and within your overall systems. You shall be solely responsible for deciding whether to adopt/use Epson products with your products.
- Epson has prepared this document carefully to be accurate and dependable, but Epson does not guarantee that the information is always accurate and complete. Epson assumes no responsibility for any damages you incurred due to any misinformation in this document.
- No dismantling, analysis, reverse engineering, modification, alteration, adaptation, reproduction, etc., of Epson products is allowed.
- Epson products have been designed, developed and manufactured to be used in general electronic applications and specifically requires particular quality or extremely high reliability in order to refrain from causing any malfunction or failure leading to critical harm to life and health, serious property damage, or severe impact on society, including, but not limited to listed below ("Specific Purpose"). Therefore, you are strongly advised to use Epson products only for the Anticipated Purpose.  
Should you desire to purchase and use Epson products for Specific Purpose, Epson makes no warranty and disclaims with respect to Epson products, whether express or implied, including without limitation any implied warranty of merchantability or fitness for any Specific Purpose. Please be sure to contact our sales representative in advance, if you desire Epson products for Specific Purpose:  
Space equipment (artificial satellites, rockets, etc.) / Transportation vehicles and their control equipment (automobiles, aircraft, trains, ships, etc.) / Medical equipment / Relay equipment to be placed on sea floor / Power station control equipment / Disaster or crime prevention equipment / Traffic control equipment/ Financial equipment.  
Other applications requiring similar levels of reliability as the above.
- Epson products listed in this document and our associated technologies shall not be used in any equipment or systems that laws and regulations in Japan or any other countries prohibit to manufacture, use or sell. Furthermore, Epson products and our associated technologies shall not be used for the purposes of military weapons development (e.g. mass destruction weapons), military use, or any other military applications. If exporting Epson products or our associated technologies, please be sure to comply with the Foreign Exchange and Foreign Trade Control Act in Japan, Export Administration Regulations in the U.S.A (EAR) and other export-related laws and regulations in Japan and any other countries and to follow their required procedures.
- Epson assumes no responsibility for any damages (whether direct or indirect) caused by or in relation with your non-compliance with the terms and conditions in this document or for any damages (whether direct or indirect) incurred by any third party that you give, transfer or assign Epson products.
- For more details or other concerns about this document, please contact our sales representative.
- Company names and product names listed in this document are trademarks or registered trademarks of their respective companies.