

Application Manual

Real Time Clock Module

RX6110SA B
(Tolerance B : $5 \pm 23 \times 10^{-6}$)

NOTICE

- This material is subject to change without notice.
- Any part of this material may not be reproduced or duplicated in any form or any means without the written permission of Seiko Epson.
- The information about applied circuitry, software, usage, etc. written in this material is intended for reference only. Seiko Epson does not assume any liability for the occurrence of infringing on any patent or copyright of a third party. This material does not authorize the licensing for any patent or intellectual copyrights.
- When exporting the products or technology described in this material, you should comply with the applicable export control laws and regulations and follow the procedures required by such laws and regulations.
- You are requested not to use the products (and any technical information furnished, if any) for the development and/or manufacture of weapon of mass destruction or for other military purposes. You are also requested that you would not make the products available to any third party who may use the products for such prohibited purposes.
- These products are intended for general use in electronic equipment. When using them in specific applications that require extremely high reliability, such as the applications stated below, you must obtain permission from Seiko Epson in advance.
 - / Space equipment (artificial satellites, rockets, etc.) / Transportation vehicles and related (automobiles, aircraft, trains, vessels, etc.) / Medical instruments to sustain life / Submarine transmitters / Power stations and related / Fire work equipment and security equipment / traffic control equipment / and others requiring equivalent reliability.
- All brands or product names mentioned herein are trademarks and/or registered trademarks of their respective.

ETM40E Revision History

Rev No.	Date	Page	Description
ETM40E-01	02.Dec.2013		Release
ETM40E-02	15.Oct.2014	10,33	Corrected a power-on reset procedure by the software command.
		30,31	Added a 14.9. Digital offset function
		6	Added a Low-level output voltage VOL6
		15,17,28 29,32	An exhibition of an IOCUTEN function and a flow chart review with it. (bit4 of address 31h(I2C),bit4 of address 1 of BANK3(SPI))
		17	Added a comment to 13.3.7. Reserved bit
ETM40E-03	12.Apr.2016	5	Added a rank of the frequency tolerance [tolerance B].
			Corrected a condition of the frequency / voltage characteristic.
		6	Corrected a condition of the current consumption.
		10	Corrected a [10.2.2. Characteristic for the fluctuation of the power supply].
		13	Added a [11.2. Reference characteristic data (Typical)]
		14	Added a [(6) Installation of charged battery.] in [12. Application notes]
		16,18	Added a rank of the frequency tolerance [tolerance B] in Register table .
29	Added a description in [14.8.2. Related register of Battery backup switchover function].		

Contents

1. Overview.....	1
2. Block Diagram	1
3. Terminal description	2
4. External connection example	3
5. External Dimensions / Marking Layout.....	4
6. Absolute Maximum Ratings	5
7. Recommended Operating Conditions	5
8. Frequency Characteristics	5
9. Electrical Characteristics	6
10. Matters that demand special attention on use.....	9
11. Reference information	12
12. Application notes	14
13. Overview of Functions and Description of Registers.....	15
13.1. Overview of Functions	15
13.2. Register table	16
13.3. Description of registers.....	17
14. How to use.....	19
14.1. Clock calendar explanation	19
14.2. Fixed-cycle Timer Interrupt Function	20
14.3. Alarm Interrupt Function	24
14.4. Time Update Interrupt Function.....	26
14.5. Frequency stop detection function	27
14.6. 1Hz output function.....	28
14.7. FOUT function [clock output function]	28
14.8. Battery backup switchover function	29
14.9. Digital offset function	31
14.10. Flow-chart.....	33
14.11. Reading/Writing Data via the I ² C Bus Interface	37
14.12. Reading/Writing Data via the SPI Bus Interface.....	40

Low current consumption
SERIAL-INTERFACE REAL TIME CLOCK MODULE

RX 6110 SA B

- Built in frequency adjusted 32.768-kHz crystal unit.
- Real-time clock function : Clock/calendar function, Long timer function, alarm interrupt function, etc.
- User RAM : Built in 128 bit RAM
- 32.768 kHz output function : C-MOS or N-ch Open drain
- Interface type : Selectable I2C-Bus and SPI-Bus by pin.
- Interface voltage range : 1.6 V ~ 5.5 V
- Timekeeper voltage range : 1.1 V ~ 5.5 V
- Built-in Backup switchover circuit : Battery backup switchover function is the automatic switchover circuit.
- Interface power supply input pin. : Power supply can use the backup charge voltage and the interface voltage with the other voltage
- Backup current consumption : 130 nA _{Typ} / 3 V

The I²C-Bus is a trademark of NXP Semiconductors.

1. Overview

This is a real-time clock module of the serial interface system that incorporates a 32.768 kHz crystal oscillator. The real-time clock function incorporates not only a calendar and clock counter for the year, month, day, day of the week, hour, minute, and second, but also a time alarm, interval timer, and time update interruption, among other features. By the battery backup switchover function and the interface power supply input pin, RX6110SA can support various power supply circuitries. All of these many functions are implemented in a thin, compact SOP package, which makes it suitable for various kinds of small electronic devices.

2. Block Diagram

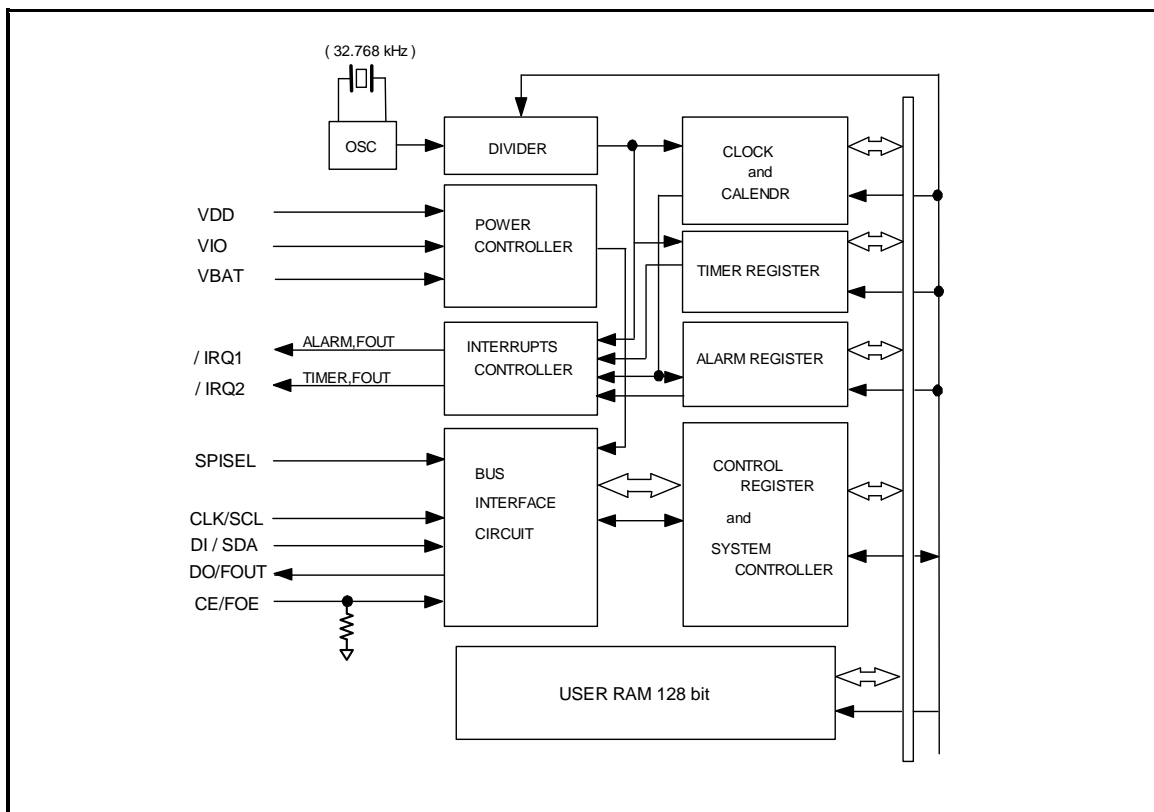

3. Terminal description

3.1. Terminal connections

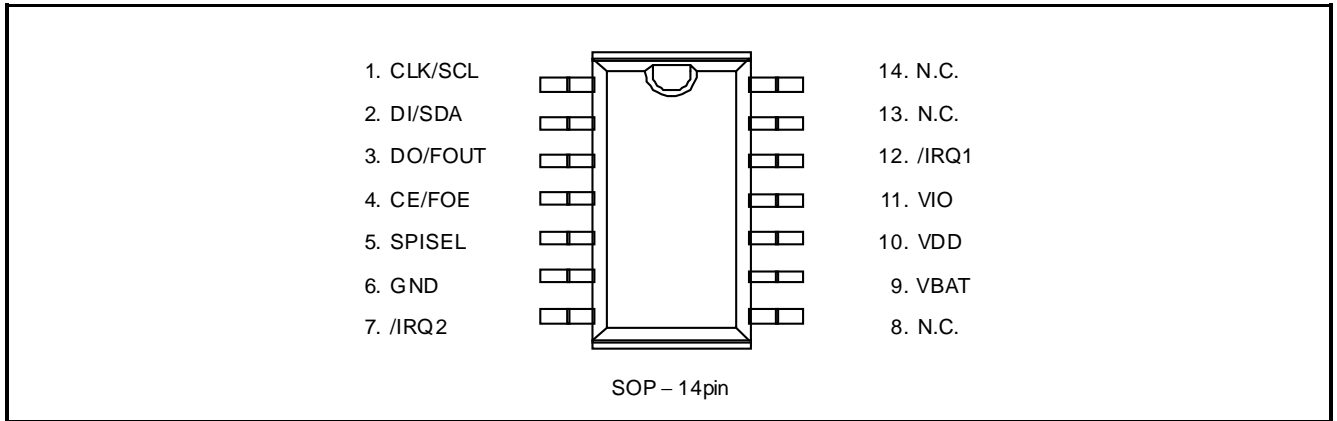

3.2. Pin Functions

Signal name	I/O	Function
SPISEL	Input	Interface selection pin. SPI is chosen at a "H" level (V _{IO} voltage). I ² C is chosen at a "L" level (GND voltage). Slave address [0110010]
CE/FOE	Input	SPI: Should be held high to allow access to the CPU. Incorporates a pull-down resistor. I ² C: It is an input pin for controlling the DO/FOUT output. When the frequency output from a DO/FOUT pin does not need, CE/FOE pin must be connected to GND.
CLK/SCL	Input	This is a shift clock input pin for serial data transmission.
DI/SDA	Input/Output	SPI: This is the data input pin for serial data transfer. I ² C: This is the data input/output pin for serial data transfer.
DO/FOUT	Output	SPI: This is the data output pin for serial data transfer. I ² C: This is the C-MOS output pin with output control provided via the CE/FOE pin. (frequency selection: 32.768 kHz / 1024 Hz / 1Hz / Hi-z)
/ IRQ1	Output	This pin outputs interrupt signals ("L" level) for alarm, timer, time update, and FOUT. This is an N-ch open-drain output. This pin can output even a backup mode.
/ IRQ2	Output	This pin outputs interrupt signals ("L" level) for timer and FOUT. This is an C-MOS output. This pin becomes Hi-z in less than V _{DD} =1.6V.
V _{DD}	Supply	This is a power-supply pin. It can impress the voltage unlike V _{IO} .
V _{IO}	Supply	This is a interface power supply pin. This is a pin to supply the voltage same as a host.
V _{BAT}	Supply	This is a power supply pin for backup battery. This is a pin to connect a large-capacity capacitor, a secondary battery. When the battery switchover function does not need, V _{BAT} must be connected to V _{DD} .
GND	Supply	This pin is connected to a ground.

Note: Input pins are able to input up to 5.5V regardless of V_{IO} applied voltage.

Note: Open drain pins are able to Pull-up to 5.5V regardless of V_{IO} applied voltage.

Note: Connect a bypass capacitor rated at least 0.1μF between power supply pins and GND pin.

4. External connection example

4.1. Interface connection example

Ex.1. I²C-Bus

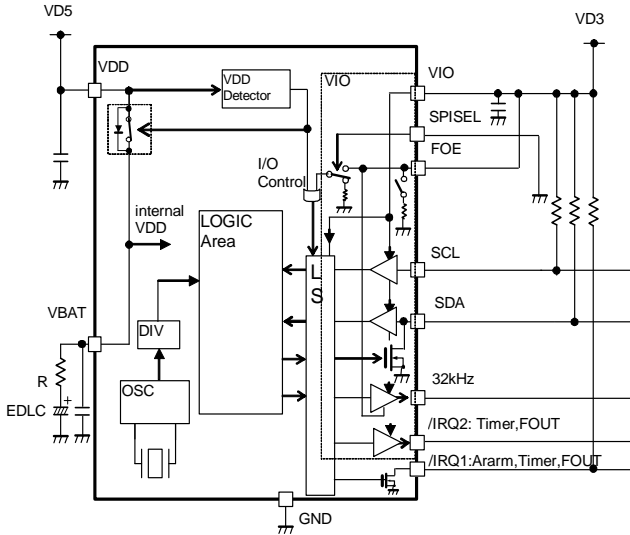

Ex.2 SPI-Bus

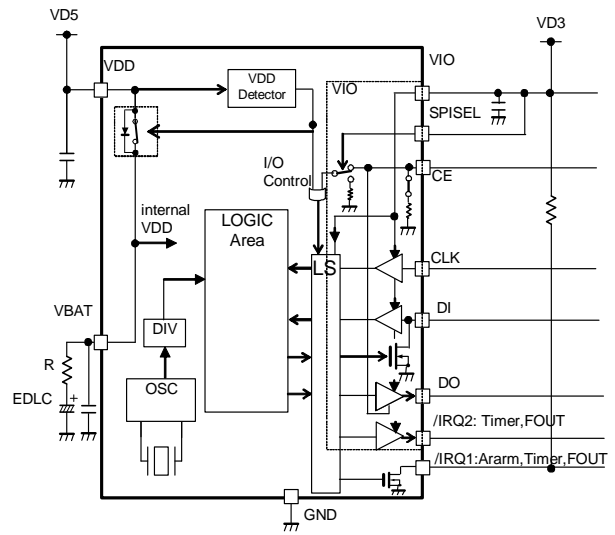

4.2. Power supply connection example

Ex1. The circuit which charges battery by high voltage

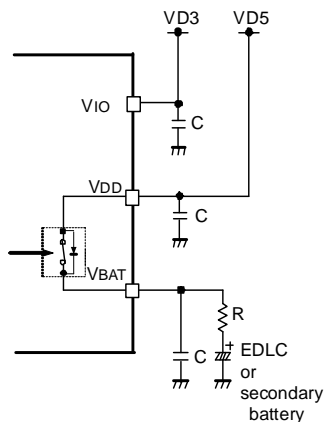

Ex.2 A circuit to use with the same system power supply

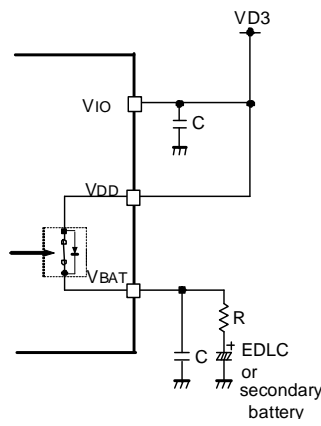

Ex.3 A circuit to connect a primary cell

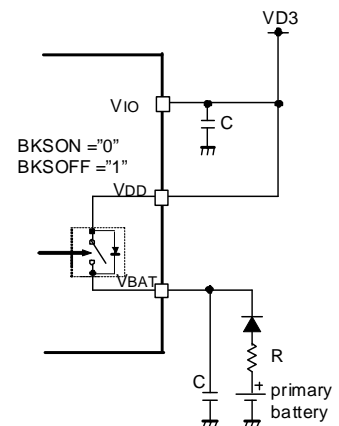

Ex.4 The circuit where backup is unnecessary

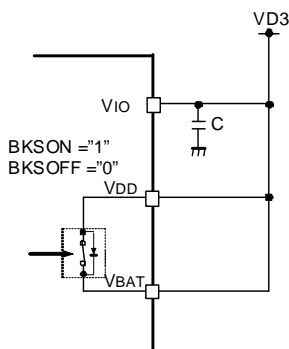

5. External Dimensions / Marking Layout

5.1. External Dimensions

RX6110 SA B (SOP – 14 pin)

- External dimensions
- Recommended soldering pattern

The technical drawings include:

- Top view:** Shows a rectangular component with a width of 10.1 ± 0.2 mm and a height of 7.4 ± 0.2 mm. Pin #14 is on the left and pin #8 is on the right. Pin #1 is at the bottom left and pin #7 is at the bottom right. A dashed circle indicates the location of a crystal oscillator cylinder.
- Side view:** Shows the component's profile with a lead angle of $0^\circ - 10^\circ$. The lead height is 0.6 mm and the lead thickness is 0.15 mm.
- Bottom view:** Shows the component's thickness of 3.2 ± 0.1 mm. The lead thickness is 0.05 mm (minimum). Pin spacing dimensions are 0.35 mm, 1.27 mm, and 1.2 mm.
- Recommended soldering pattern:** Shows the soldering area with a height of 1.4 mm and a width of $1.27 \times 6 = 7.62$ mm. The distance between the soldering area and the component body is 5.4 mm.

Unit : mm

* The cylinder of the crystal oscillator can be seen in this area (front), but it has no affect on the performance of the device.

5.2. Marking Layout

RX6110 SA B (SOP – 14 pin)

The marking layout diagram shows a rectangular component with the following markings:

- Type:** R 6110
- Logo:** E A123B
- Production lot:** (indicated by a line pointing to the right)

* Contents displayed indicate the general markings and display, but are not the standards for the fonts, sizes and positioning.

6. Absolute Maximum Ratings

GND = 0 V

Item	Symbol	Condition	Rating	Unit
Supply voltage 1	VDD	Between VDD and GND	-0.3 ~ +6.5	V
Supply voltage 2	VIO	Between VIO and GND	-0.3 ~ +6.5	V
Supply voltage 3	VBAT	Between VBAT and GND	-0.3 ~ +6.5	V
Input voltage	VIN	SPISEL, CE/FOE, CLK/SCLK	-0.3 ~ +6.5	V
Output voltage 1	VOUT1	DO/FOUT, /IRQ2	-0.3 ~ VIO+0.3	V
Output voltage 2	VOUT2	DI/SDA, /IRQ1 A case of the Open drain output pin setting	-0.3 ~ +6.5	V
Storage temperature	TSTG	When stored separately, without packaging	-55 to +125	°C

7. Recommended Operating Conditions

*Unless otherwise specified, GND = 0 V, Ta = -40 °C to +85 °C

Item	Symbol	Condition	Min.	Typ.	Max.	Unit
Operating supply voltage	VACC	VDD, VIO pin	1.6	3.0	5.5	V
Clock supply voltage	VCLK	VDD, VBAT pin	1.1	3.0	5.5	V
Main power supply Low voltage detection	VDET+	VDD pin, Rise	1.15	1.35	1.60	V
	VDET-	VDD pin, Fall	1.10	1.30	1.55	V
Backup power supply Low voltage detection	VLOW	VBAT pin			1.10	V
Applied voltage when OFF	VPUP	DI/SDA, /IRQ1pin			5.5 *	V
Operating temperature	TOPR	No condensation	-40	+25	+85	°C

*Minimum value of Clock supply voltage VCLK is the timekeeping continuation lower limit value that initialized RX6110 in operating supply voltage VACC.

*The tolerance level of the power supply voltage that can connect with the pulling up in the state that VDD, VIO are power off.

8. Frequency Characteristics

*Unless otherwise specified, GND = 0 V, Ta = -40 °C to +85 °C

Item	Symbol	Condition	Min.	Typ.	Max.	Unit
Output frequency	fo			32.768 (Typ.)		kHz
Frequency tolerance	$\Delta f / f$	Ta = +25 °C VDD = 3.0 V	tolerance B: $5 \pm 23^{(*1)}$			$\times 10^{-6}$
Frequency/voltage characteristics	f / V	Ta = +25 °C VDD = 1.1 V ~ 5.5 V	-2		+2	$\times 10^{-6} / V$
Frequency/temperature characteristics	Top	Ta = -20 °C ~ +70 °C VDD = 3.0 V ; +25 °C reference	-120		+10	$\times 10^{-6}$
Oscillation start time	tSTA	Ta = ± 0 °C ~ +50 °C VDD = 1.6 V ~ 5.5 V		0.3	1.0	s
		Ta = -40 °C ~ +85 °C VDD = 1.6 V ~ 5.5 V			3.0	s
Aging	fa	Ta = +25 °C, VBAT = 3.0 V ; first year	-5		+5	$\times 10^{-6} / \text{year}$

*1) The monthly error is equal to one minute. (excluding offset)

9. Electrical Characteristics

9.1. DC characteristics

9.1.1. DC characteristics (1)

*Unless otherwise specified, GND = 0 V , V_{BAT}=V_{DD} = 1.1 V ~ 5.5 V , V_{IO}= 1.6 V ~ 5.5 V ,
T_a = -40°C ~ +85°C

Item	Symbol	Condition		Min.	Typ.	Max.	Unit
Current consumption (1)	I _{DD1}	Input pins are "L" , V _{DD} = 0 V DO/FOUT=OFF f _{CLK} = 0 Hz, /IRQ1,2 = OFF TSEL2=1,		V _{BAT} = 5 V		270	nA
Current consumption (2)	I _{DD2}	It include an OFF leak current of SW between the power supply (V _{BAT} -V _{DD})		V _{BAT} = 3 V		130 250	nA
Current consumption (4)	I _{DD4}	f _{CLK} = 0 Hz, /IRQ1,2 = OFF, CE/FOE = V _{IO} , DO/FOUT : 32.768 kHz ON ,		V _{DD} = 5 V V _{IO} = 5 V	2.5	3.3	μA
Current consumption (5)	I _{DD5}	CL = 0 pF Total current V _{DD} and V _{IO} pin.		V _{DD} = 3 V V _{IO} = 3 V	1.5	2.1	
Current consumption (6)	I _{DD6}	f _{CLK} = 0 Hz, /IRQ1,2 = OFF, CE/FOE = V _{IO} , DO/FOUT : 32.768 kHz = ON ,		V _{DD} = 5 V V _{IO} = 5 V	5.5	7.0	μA
Current consumption (7)	I _{DD7}	CL = 15 pF Total current V _{DD} and V _{IO} pin.		V _{DD} = 3 V V _{IO} = 3 V	3.0	4.0	
High-level input voltage	V _{IH}	SPISEL, CE/FOE pin		0.7 × V _{IO}		5.5	V
	V _{IHSPI}	CLK/SCL, DI/SDA pin, SPISEL=V _{IO} *		0.7 × V _{IO}		5.5	V
	V _{IHI2C}	CLK/SCL, DI/SDA pin, SPISEL=GND*		0.8 × V _{IO}		5.5	V
Low-level input voltage	V _{IL}	SPISEL, CE/FOE pin		GND - 0.3		0.3 × V _{IO}	V
	V _{ILSPI}	CLK/SCL, DI/SDA pin, SPISEL=V _{IO}		GND - 0.3		0.3 × V _{IO}	V
	V _{ILI2C}	CLK/SCL, DI/SDA pin, SPISEL=GND		GND - 0.3		0.2 × V _{IO}	V
High-level output voltage	V _{OH1}	DO/FOUT pin	V _{IO} =5 V, I _{OH} =-1 mA	4.5		5.0	V
	V _{OH2}	/IRQ2 pin	V _{IO} =3 V, I _{OH} =-0.5 mA	2.7		3.0	
Low-level output voltage	V _{OL1}	DO/FOUT pin	V _{IO} =5 V, I _{OL} =1 mA	GND		GND +0.5	V
	V _{OL2}	/IRQ2 pin	V _{IO} =3 V, I _{OL} =0.5 mA	GND		GND +0.3	
	V _{OL4}	/IRQ1 pin	V _{BAT} =5 V, I _{OL} =1 mA	GND		GND +0.25	V
	V _{OL5}		V _{BAT} =3 V, I _{OL} =1 mA	GND		GND +0.4	
	V _{OL6}	DI/SDA pin	V _{IO} ≥ 2 V, I _{OL} =3.0 mA	GND		GND +0.4	V
Input leakage current	I _{LK}	Input pins(excluding CE/FOE), V _{IN} = V _{IO} or GND		-0.1		0.1	μA
	I _{LKPD}	CE/FOE pin, V _{IN} = GND		-0.1		0.1	
Input leakage current	I _{OZ}	Output pins, V _{OUT} = V _{IO} or GND		-0.1		0.1	μA
SW - ON * resistance	R _{SWON}	SW - ON resistance between V _{DD} and V _{BAT}		V _{DD} = 5V	250	500	Ω
				V _{DD} = 3V	400	650	
Input resistance(1)	R _{DWN1}	Pull-down resistance of CE/FOE pin.		V _{DD} = 5V	75	150	kΩ
Input resistance(2)	R _{DWN2}	V _{IN} = V _{IO}		V _{DD} = 3V	150	300	

* When a DI/SDA pin connects with a DO/FOUT pin, Maximum value of High-level input voltage of the DI/SDA pin becomes the V_{IO}+0.3 V.

* The current consumption are target specifications.

* SW-ON resistance between V_{DD} and V_{BAT} of Backup switchover circuit

9.2. AC characteristics

9.2.1. AC characteristics (1) I²C-Bus interface (SPISEL pin = "L")

*Unless otherwise specified, GND = 0 V , V_{IO} = 1.6 V ~ 5.5 V , T_a = -40°C ~ +85°C

Item	Symbol	Standard-Mode (f _{SCL} =100kHz)		Fast-Mode (f _{SCL} =400kHz)		Unit
		Min.	Max.	Min.	Max.	
SCL clock frequency	f _{SCL}		100		400	kHz
Start condition setup time	t _{SU} ;STA	4.7		0.6		μs
Start condition hold time	t _{HD} ;STA	4.0		0.6		μs
Data setup time	t _{SU} ;DAT	250		100		ns
Data hold time	t _{HD} ;DAT	0		0		ns
Stop condition setup time	t _{SU} ;STO	4.0		0.6		μs
Bus idle time between start condition and stop condition	t _{BUF}	4.7		1.3		μs
Time when SCL = "L"	t _{LOW}	4.7		1.3		μs
Time when SCL = "H"	t _{HIGH}	4.0		0.6		μs
Rise time for SCL and SDA	t _r		1.0		0.3	μs
Fall time for SCL and SDA	t _f		0.3		0.3	μs
Allowable spike time on bus	t _{SP}		50		50	ns

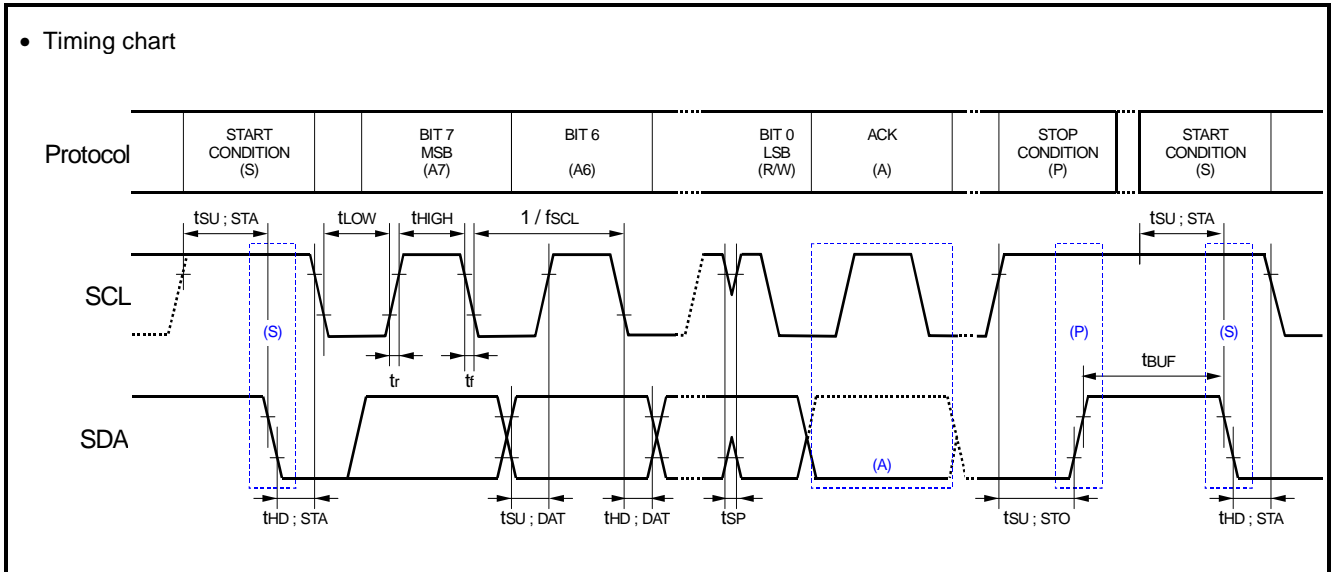

Caution:When accessing this device, all communication from transmitting the start condition to transmitting the stop condition after access should be completed within 0.95 seconds.
If such communication requires 0.95 seconds or longer, the I²C bus interface is reset by the internal bus timeout function.

9.2.1. AC characteristics (2) SPI-Bus interface (SPISEL pin = "H")

*Unless otherwise specified, GND = 0 V , VDD = 1.6 V ~ 5.5 V , Ta = -40°C ~ +85°C

Item	Symbol	Condition	VIO=1.8V ±0.2V		VIO=3.0V ±10%		VIO=5.0V ±10%		Unit
			Min.	Max.	Min.	Max.	Min.	Max.	
CLK clock cycle	tCLK		1000	-	500	-	350	-	ns
CLK H pulse width	tWH		450	-	250	-	175	-	ns
CLK L pulse width	tWL		450	-	250	-	175	-	ns
CLK rise and fall time	tRF		-	100	-	100	-	50	ns
CLK setup time	tCLKS		100	-	50	-	30	-	ns
CE setup time	tCS		400	-	200	-	150	-	ns
CE hold time	tCH		400	-	200	-	100	-	ns
CE recovery time	tCR		500	-	300	-	200	-	ns
CE enable time	tWCE		-	0.95	-	0.95	-	0.95	s
Write data setup time	tCERF		-	-	-	100	-	50	ns
Write data hold time	tDS		200	-	100	-	50	-	ns
Read data delay time	tDH		200	-	100	-	50	-	ns
DO output switching time	tRD	CL = 50 pF	0	400	-	200	-	150	ns
DO output disable time	tRZ	CL = 50 pF RL = 10 kΩ	0	400	-	200	-	120	ns
DI/DO conflict avoiding time	tZZ		0	-	0	-	0	-	ns

- Caution: 1. Please refer to a standard of VIO = 1.8V ±0.2V for VIO = 2.0 V ~ 2.7 V.
 2. Please refer to a standard of VIO = 3.0V ±10% for VIO = 3.3 V ~ 4.5 V.
 3. The access to this device must be finished within 0.95 seconds(CE enable time).
 When access continues more than 0.95 seconds, second update fails.

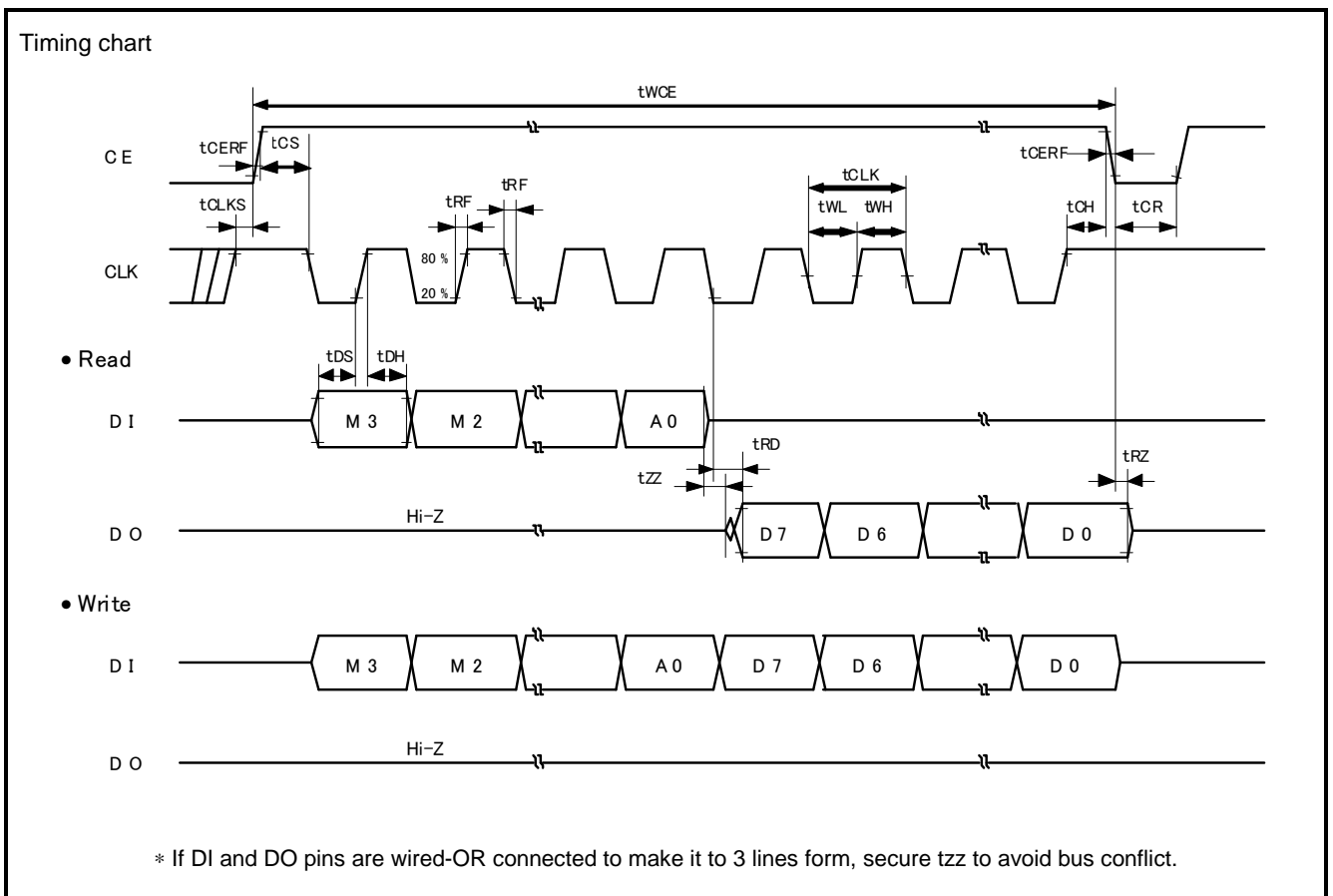

9.2.2. AC characteristics (3)

*Unless otherwise specified, GND = 0 V , V_{IO} = 1.6 V ~ 5.5 V , T_a = -40°C ~ +85°C

Item	Symbol	Condition	Min.	Typ.	Max.	Unit
FOUT symmetry	SYM	50% V _{IO} Level	40	50	60	%

10. Matters that demand special attention on use

10.2. Instructions in the power on

10.2.1. Procedure of the power-on

V_{DD} and V_{IO} separate and can give different power supplies.
 In specifications range, the voltage relations(V_{DD} and V_{IO}) are free.

In the status that the voltage more than V_{DET+} was supplied to main power-source V_{DD}, if power-source V_{IO} for an interface becomes unstable with the middle electric potential between GND-V_{DD}, a through current will flow. V_{IO} becomes unsettled, and an electric current of about 10uA flows when a through current flows by voltage relations of V_{DD} and V_{IO}. When the V_{IO} voltage comes to stabilize, the through current of 10uA does not flow. If can permit this 10uA, V_{DD} and V_{IO} and V_{BAT} completely impress it by an independent timing and do not have any problem. By this through current, RTC does not destroy it and the malfunction does not occur.

If can not permit this 10uA, the following power-up is recommended.
 When the power-source supply of V_{DD} is carried out earlier than V_{IO}, please start V_{IO} from a GND level not to become unstable.

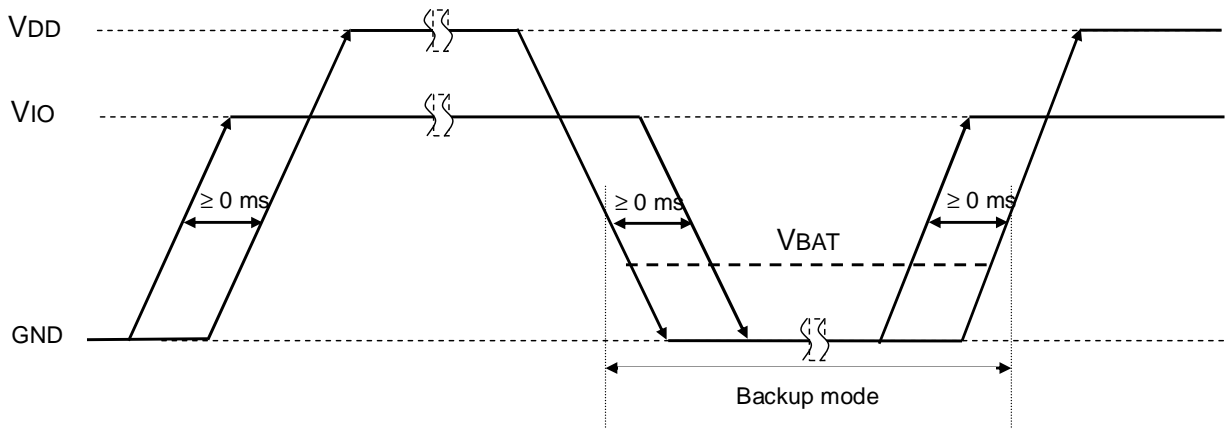

10.2.2. Characteristic for the fluctuation of the power supply

*tR1 is restrictions to validate power-on reset. When cannot keep this standard, power-on reset does not work normally. It is necessary to initial setting by the software command.

Repeated ON/OFF of the power supply in short term, the power-on reset becomes unstable. After power-OFF, keep a state of VBAT=GND more than 60 seconds to validate power-on reset. When it is impossible, please perform initial setting by the software command.

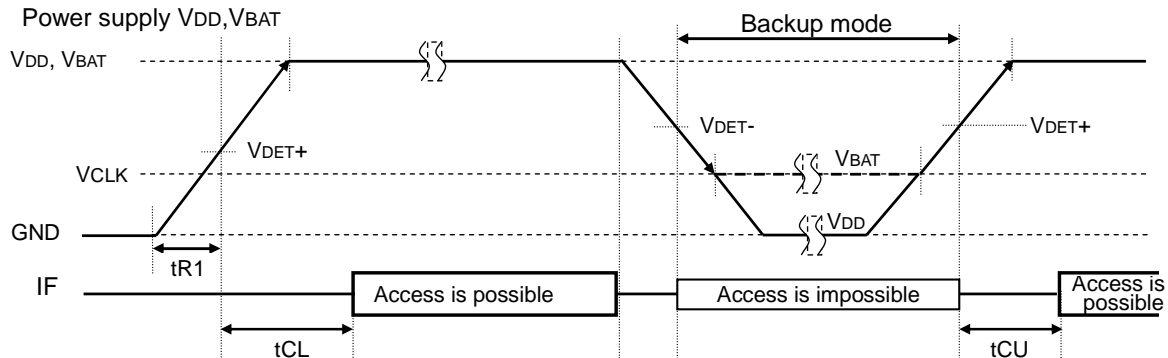

Item	Symbol	Condition	Min.	Typ.	Max.	Unit
Power supply rise time	tR1	VDD rise time :GND – VDET+ VBAT rise time: GND – VCLK	1	-	100	μs / V
access wait time (Initial power on)	tCL	VDD > VDET+, VBAT > VCLK	40	-	-	ms
access wait time (Normal power on)	tCU	VDD > VDET+, VBAT > VCLK	40	-	-	ms

A power-on reset procedure by the software command

I²C-Bus interface (SPISEL pin = "L")

SPI-Bus interface (SPISEL pin = "H")

- | | |
|---|---|
| <ol style="list-style-type: none"> 1) Power- on 2) Wait: At least 40ms. 3) Dummy read. *1 4) Check VLF bit = "1" 5) Write 00[h] Address:Reg-31[h] *2 6) Write 00[h] Address:Reg-1F[h] 7) Write 80[h] Address:Reg-1F[h] 8) Write D3[h] Address:Reg-60[h] 9) Write 03[h] Address:Reg-66[h] 10) Write 02[h] Address:Reg-6B[h] 11) Write 01[h] Address:Reg-6B[h] 12) Wait: At least 2ms *3 <p>END</p> | <ol style="list-style-type: none"> 1) Power- on 2) Wait: At least 40ms. 3) Check VLF bit = "1" 4) Write 00[h] Address SPI: BANK3 Reg-1[h] *2 5) Write 00[h] Address SPI: BANK1 Reg-F[h] 6) Write 80[h] Address SPI: BANK1 Reg-F[h] 7) Write D3[h] Address SPI: BANK6 Reg-0[h] 8) Write 03[h] Address SPI: BANK6 Reg-6[h] 9) Write 02[h] Address SPI: BANK6 Reg-B[h] 10) Write 01[h] Address SPI: BANK6 Reg-B[h] 11) Wait: At least 2ms *3 <p>END</p> |
|---|---|

*1 Dummy read(I²C-Bus Only)

The location of the address is arbitrary.Do not check ACK/NACK from RX6110.

*2 This command must be sent when executing the soft reset, even if the VLF="0". (There is not influence even if it transmit at the time of VLF="1")

*3 This wait time is necessary before transmitting the command for clearing VLF bit after software reset command transmission.

*4 SPI-Bus setting code (Please refer to [14.12. Reading/Writing Data via the SPI Bus Interface] for the details.)

Mode	Bank1	Bank6
Read	9h	Eh
Write	1h	6h

A disappearance of the FOUT output when the voltage sharply went up and down.

For example, VBAT voltage is come and go between Main power and backup battery.

The clock output from output pins and internal clock disappears then during several milli-seconds when a sharp voltage change happens.

Please check that there is not a problem by this characteristic on your system.

An reference example of a power up and down timing without affect to FOUT.

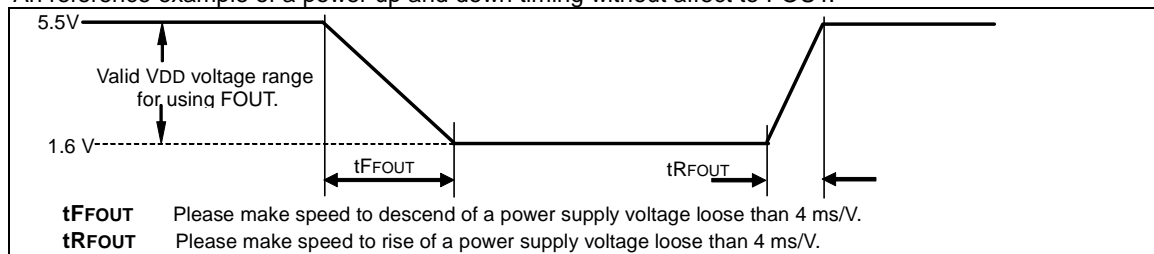

10.3. Restrictions on Access Operations During Power-on Initialization and Recovery from Backup

- RTC-register operations are linked to the internal quartz oscillator's clock signal, so normal operation is not possible if there is no internal oscillation (= oscillation is stopped).
Therefore, we recommend that the initial setting to be set during power-on initialization or backup and restore operations (i.e., when the power supply voltage is recovered after oscillation has stopped due to a voltage drop, etc.) should be "first start internal oscillation, then wait for the oscillation stabilization time (see tSTA standard) to elapse".
- Note the following caution points concerning access operations during power-on initialization or when restoring the power supply voltage from backup mode (hereafter referred to as "switching to the operating voltage").
 - 1) Before switching to the operating voltage, read the VLF-bit (which indicates the RTC error status).
 - 2) Initialization is required when the value read from the VLF-bit is "VLF = 1 (error status)".
Before initializing in response to this VLF = "1" result, we recommend first waiting for the internal oscillation stabilization time (see the tSTA standard) to elapse.

Initialization is required when the status after reading a VLF-bit value of "1" is either of the following.
 (Status 1) During power-on initialization
 (Status 2) When the clock setting is invalid, such as due to a voltage drop during backup

* Access timing during power-on initialization and when recovering the power supply voltage after a drop in the voltage used to maintain the clock

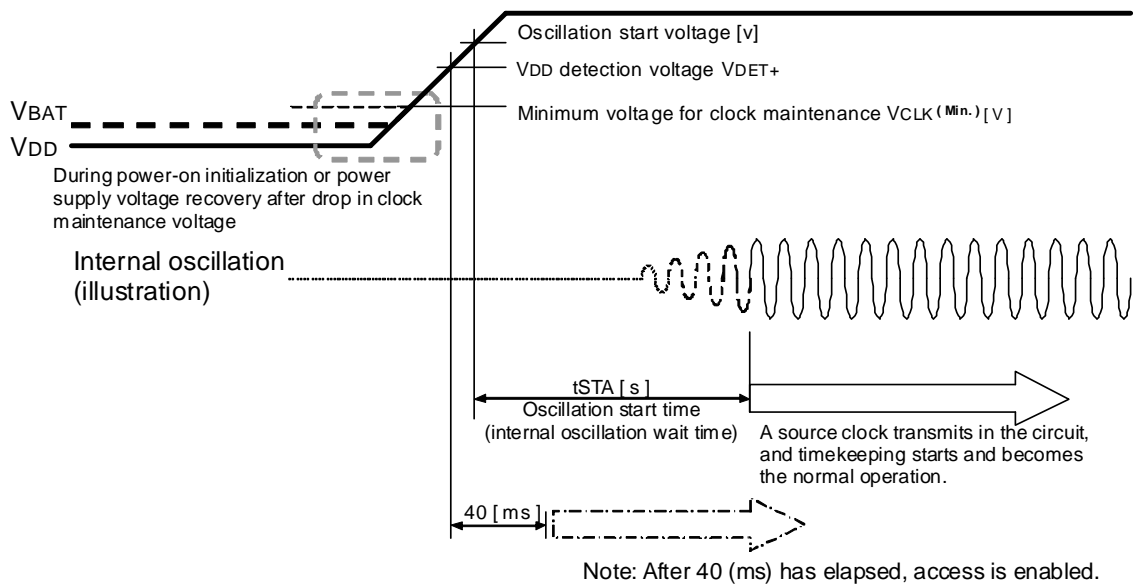

• Recovery from Backup

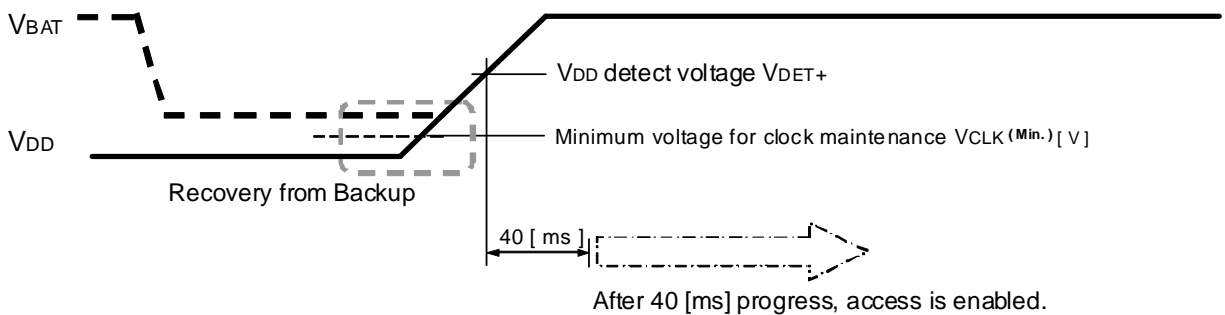

Because interface disable before 40 [ms], reading data are indefinite.

11. Reference information

11.1. Reference Data

(1) Example of frequency and temperature characteristics

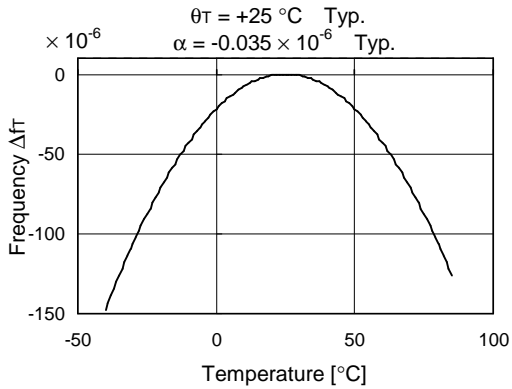

[Finding the frequency stability]

1. Frequency and temperature characteristics can be approximated using the following equations.

$$\Delta f_T = \alpha (\theta_T - \theta_x)^2$$

- Δf_T : Frequency deviation in any temperature
- $\alpha [1 / \text{ }^\circ\text{C}^2]$: Coefficient of secondary temperature
 $(-0.035 \pm 0.005) \times 10^{-6} / \text{ }^\circ\text{C}^2$
- $\theta_T [\text{ }^\circ\text{C}]$: Ultimate temperature ($+25 \pm 5 \text{ }^\circ\text{C}$)
- $\theta_x [\text{ }^\circ\text{C}]$: Any temperature

2. To determine overall clock accuracy, add the frequency precision and voltage characteristics.

$$\Delta f/f = \Delta f/f_0 + \Delta f_T + \Delta f_V$$

- $\Delta f/f$: Clock accuracy (stable frequency) in any temperature and voltage.
- $\Delta f/f_0$: Frequency precision
- Δf_T : Frequency deviation in any temperature.
- Δf_V : Frequency deviation in any voltage.

3. How to find the date difference

$$\text{Date Difference} = \Delta f/f \times 86400(\text{Sec})$$

* For example: $\Delta f/f = 11.574 \times 10^{-6}$ is an error of approximately 1 second/day.

11.2. Reference characteristic data (Typical)

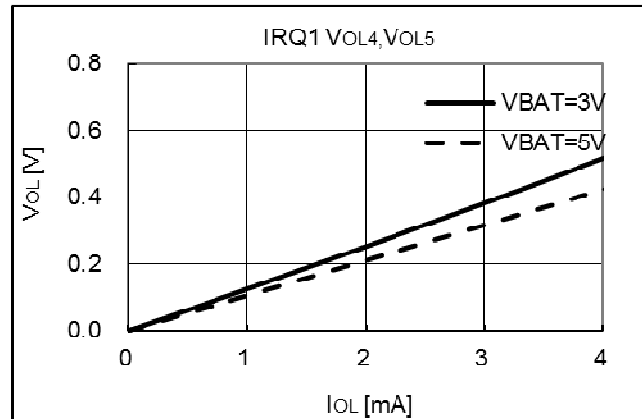
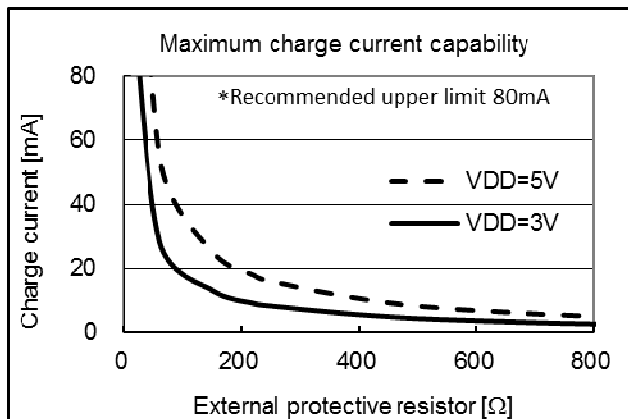
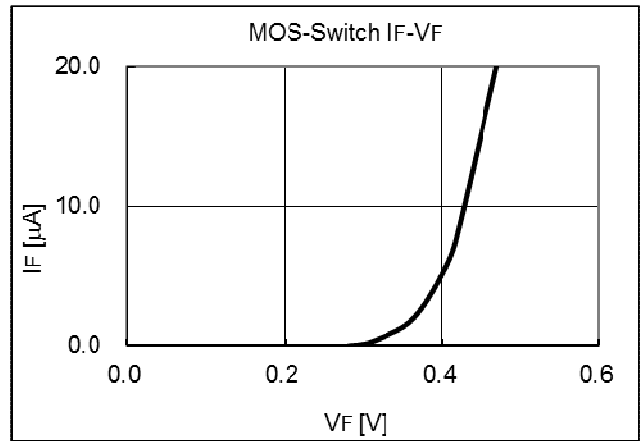
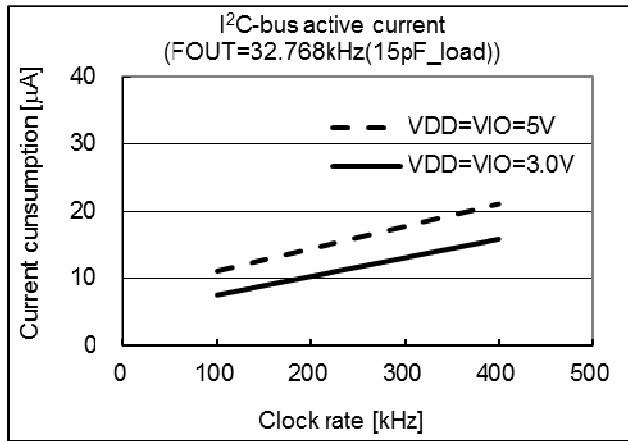
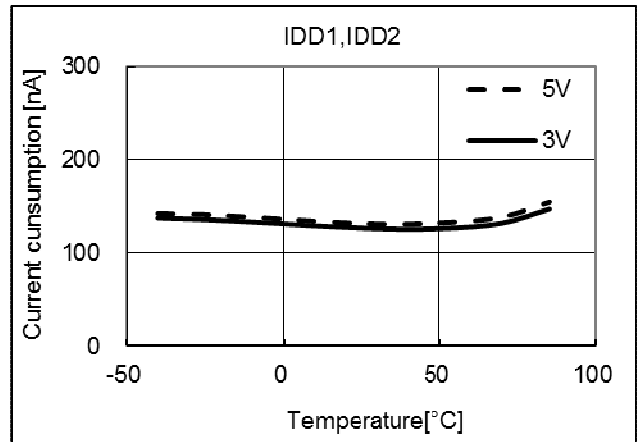
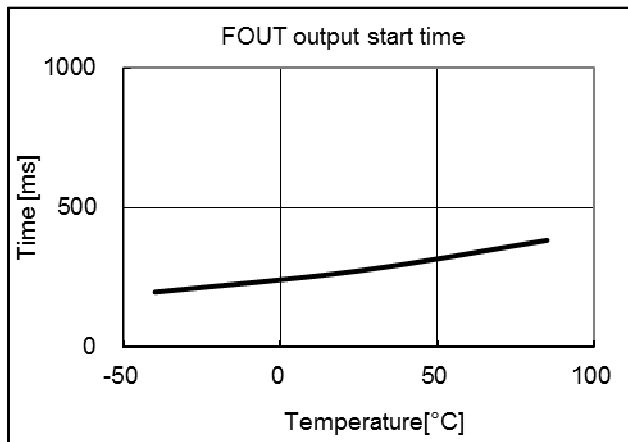
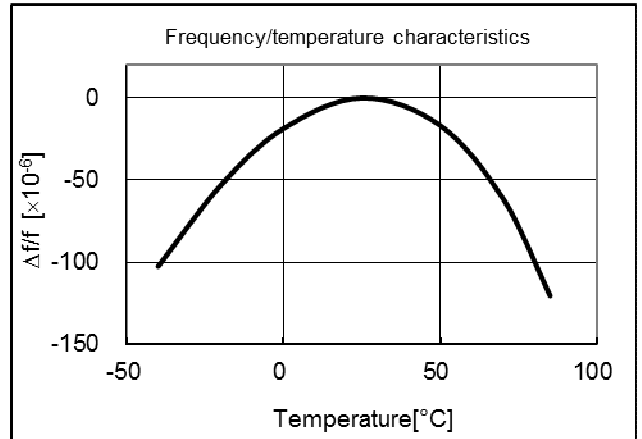
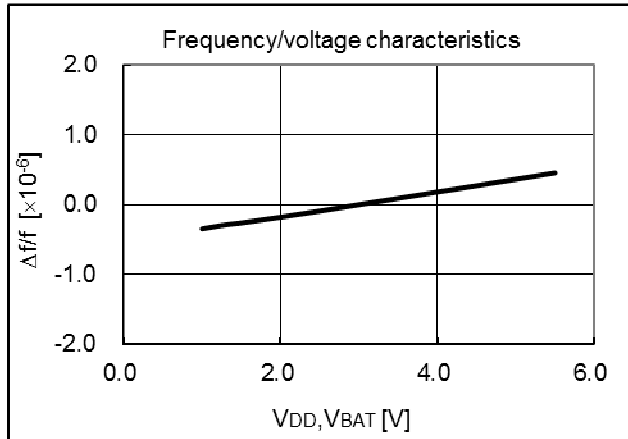

12. Application notes

1) Notes on handling

This module uses a C-MOS IC to realize low power consumption. Carefully note the following cautions when handling.

(1) Static electricity

While this module has built-in circuitry designed to protect it against electrostatic discharge, the chip could still be damaged by a large discharge of static electricity. Containers used for packing and transport should be constructed of conductive materials. In addition, only soldering irons, measurement circuits, and other such devices which do not leak high voltage should be used with this module, which should also be grounded when such devices are being used.

(2) Noise

If a signal with excessive external noise is applied to the power supply or input pins, the device may malfunction or "latch up." In order to ensure stable operation, connect a filter capacitor (preferably ceramic) of greater than 0.1 μF as close as possible to the power supply pins. Also, avoid placing any device that generates high level of electronic noise near this module.

* Do not connect signal lines to the shaded area in the figure shown in Fig. 1 and, if possible, embed this area in a GND land.

(3) Voltage levels of input pins

When the input pins are at the mid-level, this will cause increased current consumption and a reduced noise margin, and can impair the functioning of the device. Therefore, try as much as possible to apply the voltage level close to VIO or GND.

(4) Handling of unused pins

Since the input impedance of the input pins is extremely high, operating the device with these pins in the open circuit state can lead to unstable voltage level and malfunctions due to noise. Therefore, try as much as possible to apply the voltage level close to VIO or GND.

2) Notes on packaging

(1) Soldering heat resistance.

If the temperature within the package exceeds +260 °C, the characteristics of the crystal oscillator will be degraded and it may be damaged. The reflow conditions within our reflow profile is recommended. Therefore, always check the mounting temperature and time before mounting this device. Also, check again if the mounting conditions are later changed.

* See Fig. 2 profile for our evaluation of Soldering heat resistance for reference.

(2) Mounting equipment

While this module can be used with general-purpose mounting equipment, the internal crystal oscillator may be damaged in some circumstances, depending on the equipment and conditions. Therefore, be sure to check this. In addition, if the mounting conditions are later changed, the same check should be performed again.

(3) Ultrasonic cleaning

Depending on the usage conditions, there is a possibility that the crystal oscillator will be damaged by resonance during ultrasonic cleaning. Since the conditions under which ultrasonic cleaning is carried out (the type of cleaner, power level, time, state of the inside of the cleaning vessel, etc.) vary widely, this device is not warranted against damage during ultrasonic cleaning.

(4) Mounting orientation

This device can be damaged if it is mounted in the wrong orientation. Always confirm the orientation of the device before mounting.

(5) Leakage between pins

Leakage between pins may occur if the power is turned on while the device has condensation or dirt on it. Make sure the device is dry and clean before supplying power to it.

(6) Installation of charged battery.

When a charged backup battery is installed by soldering, battery connection terminal of this device should connect to GND, beforehand.

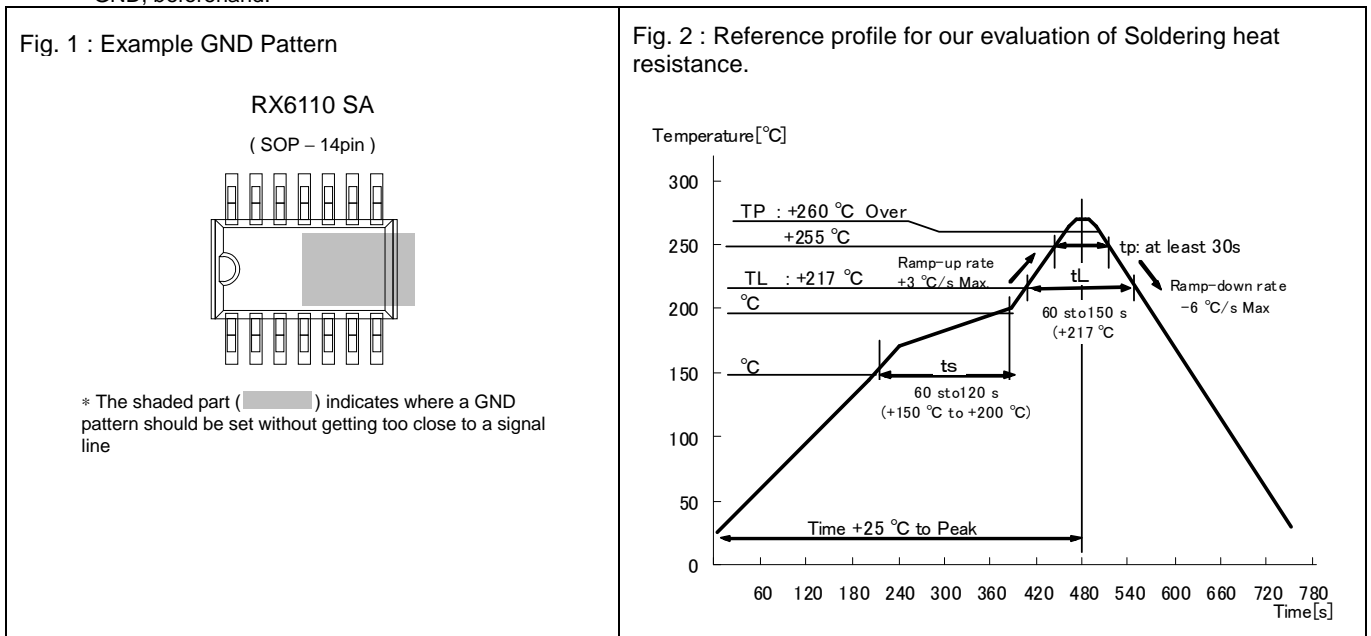

13. Overview of Functions and Description of Registers

Note:

The initialization of the register is necessary about the unused function and Reserved bit

13.1. Overview of Functions

1) Clock functions

This function is used to set and read out month, day, hour, date, minute, second, and year (last two digits) data. Any (two-digit) year that is a multiple of 4 is treated as a leap year and calculated automatically as such until the year 2099.

At the time of a communication start, the Clock & Calendar data are fixed (hold the carry operation), and it is automatically revised at the time of the communication end.

2) Fixed-cycle Timer Interrupt function

The fixed-cycle timer interrupt function generates an interrupt event periodically at any fixed cycle set between 244.14 μ s and 65535 hours.

When an interrupt event is generated, the /IRQ2 pin goes to low level ("L") and "1" is set to the TF bit to report that an event has occurred.

3) Long-Timer function

It is able to use fixed cycle timer interrupt function as Long-Timer.

This function selects the operation time with the main power supply or the operation time with the backup power supply and can automatically multiply it.

4) Alarm interrupt function

The alarm interrupt function generates interrupt events for alarm settings such as date, day, hour, and minute settings. When an interrupt event occurs, the AF bit value is set to "1" and the /IRQ1 pin goes to low level to indicate that an event has occurred.

5) Time Update Interrupt Function

The time update interrupt function generates interrupt events at one-second or one-minute intervals, according to the timing of the internal clock. When an interrupt event is generated, the /IRQ1 pin goes to low level ("L") and "1" is set to the UF bit to report that an event has occurred.

6) Voltage low detection function (VLF-bit)

This flag bit indicates the retained status of clock operations or internal data. Its value changes from "0" to "1" when data loss occurs, such as due to a supply voltage drop.

7) Clock output function

A clock with the same frequency (32.768 kHz) as the built-in crystal resonator can be output from the DO/FOUT, /IRQ1, /IRQ2 pin.

8) User RAM

RAM register is read/write accessible for any data.

9) 1Hz Output function

/IRQ1 pin outputs the Fixed-cycle pulse of one period of =1s(Hi-z = 31.25ms)

13.2. Register table

Address [h]		Function	bit 7	bit 6	bit 5	bit 4	bit 3	bit 2	bit 1	bit 0
SPI	I ² C									
BANK 1										
0	10	SEC	○	40	20	10	8	4	2	1
1	11	MIN	○	40	20	10	8	4	2	1
2	12	HOUR	○	○	20	10	8	4	2	1
3	13	WEEK	○	6	5	4	3	2	1	0
4	14	DAY	○	○	20	10	8	4	2	1
5	15	MONTH	○	○	○	10	8	4	2	1
6	16	YEAR	80	40	20	10	8	4	2	1
7	17	Reserved	-	-	-	-	-	-	-	-
		<i>(For tolerance B setting data)</i>	1	0	1	0	1	0	0	0
8	18	MIN Alarm	AE	40	20	10	8	4	2	1
9	19	HOUR Alarm	AE	•	20	10	8	4	2	1
A	1A	WEEK Alarm	AE	6	5	4	3	2	1	0
		DAY Alarm		•	20	10	8	4	2	1
B	1B	Timer Counter 0	128	64	32	16	8	4	2	1
C	1C	Timer Counter 1	32768	16384	8192	4096	2048	1024	512	256
D	1D	Extension Register	FSEL1	FSEL0	USEL	TE	WADA	TSEL2	TSEL1	TSEL0
E	1E	Flag Register	○	○	UF	TF	AF	○	VLF	○
F	1F	Control Register	TEST	STOP	UIE	TIE	AIE	TSTP	TBKON	TBKE

Address [h]		Function	bit 7	bit 6	bit 5	bit 4	bit 3	bit 2	bit 1	bit 0
SPI	I ² C									
BANK 2										
1 F	20 2F	RAM	User Register 128 bit (16 word x 8 bit)							

Address [h]		Function	bit 7	bit 6	bit 5	bit 4	bit 3	bit 2	bit 1	bit 0
SPI	I ² C									
BANK 3										
0	30	Digital Tuning	DTE	L7	L6	L5	L4	L3	L2	L1
1	31	Reserved	○	○	○	IOCUT EN	BK SON	BK SOFF	BK SMP1	BK SMP0
		<i>(Setting data)</i>	0	0	0	IOCUT EN	BK SON	BK SOFF	BK SMP1	BK SMP0
2	32	IRQ Control	○	-	-	TMREC	○	TMPIN	FOPIN1	FOPIN0
		<i>(Setting data)</i>	0	0	0	TMREC	0	TMPIN	FOPIN1	FOPIN0

Note During the initial power-on (from 0 V) and if the value of the VLF bit is "1" when the VLF bit is read, be sure to initialize all registers before using them.
When doing this, be careful to avoid setting incorrect data as the date or time, as timed operations cannot be guaranteed if incorrect date or time data has been set.

- *1. During the initial power-on (from 0 V), the power-on reset function sets "1" to the VLF bit.
* Since the value of other registers is undefined at this time, be sure to reset all registers before using them.
- *2. The **TEST** bit are Epson test bits.
* Be sure to write "0" by initializing before using the clock module. Afterward, be sure to set "0" when writing.
- *3. The '○' mark indicates a write-prohibited bit, which returns a "0" when read.
- *4. The '•' mark indicates a read/write-accessible RAM bit for any data.
- *5. The '-' mark has to write in specified fixed value in the case of initialization by all means.
- *6. User Register is a free register.

13.3. Description of registers

13.3.1. Clock and calendar counter (SPI:BANK1 Reg - 0[h] ~ 6[h] / I²C Reg - 10[h] ~ 16[h])

This is counter registers from a second to year.

* Please refer to [14.1 Clock calendar explanation] for the details.

13.3.2. RAM registers (SPI:BANK2 Reg - 0[h] ~ F[h] / I²C Reg - 20[h] ~ 2F[h])

This RAM register is read/write accessible for any data in the range from 00 h to FF h.

13.3.3. Alarm registers (SPI:BANK1 Reg - 8[h] ~ A[h] / I²C Reg - 18[h] ~ 1A[h])

The alarm interrupt function is used, along with the AE, AF, and WADA bits, to set alarms for specified date, day, hour, and minute values.

* Please refer to [14.3. Alarm Interrupt Function] for the details.

13.3.4. Timer setting and Timer counter register (SPI:BANK1 Reg - B[h] ~ C[h] / I²C Reg - 1B[h] ~ 1C[h])

This register is used to set the default (preset) value for the counter.

To use the fixed-cycle timer interrupt function, TE, TF, TIE, TSEL2, TSEL1, TSEL0, TBKON, TBKE, TMPIN bits are set and used. When the fixed-cycle timer interrupt function is not being used, the fixed-cycle timer control register can be used as a RAM register. In such cases, stop the fixed-cycle timer function by writing "0" to the TE and TIE bits.

* Please refer to [14.2. Fixed-cycle Timer Interrupt Function] for the details.

13.3.5. Function-related register 1 (SPI:BANK1 Reg - D[h] ~ F[h] / I²C Reg - 1D[h] ~ 1F[h])

1) FSEL1, FSEL0 bit

A combination of the FSEL1 and FSEL0 bits is used to select the frequency to be output.

The choice is possible by a combination of FSEL-bits and CE/FOE-pin, select the frequency of clock output or inhibit the clock output.

* Please refer to [14.6. FOUT Function] for the details.

2) USEL , UF, UIE bit

This bit is used to specify either "second update" or "minute update" as the update generation timing of the time update interrupt function.

* Please refer to [14.4. Update interrupt function] for the details.

3) TE, TF, TIE, TSEL2, TSEL1, TSEL0, TSTP, TBKON, TBKE bit

These bits are used to control operation of the fixed-cycle timer interrupt function.

4) WADA, AF, AIE bit

These bits are used to control operation of the alarm interrupt function.

5) TEST bit

Those bits are the manufacturer's test bit. Always leave this bit value as "0" except when testing.

6) VLF bit

This flag bit indicates the retained status of clock operations or internal data. Its value changes from "0" to "1" when data loss occurs, such as due to a supply voltage drop.

* Please refer to [14.5. Frequency stop detection function] for the details.

7) STOP bit

This bit is to stop a timekeeping operation. In the case of "STOP bit = 1", working is as follows a function .

* 1) All the update of timekeeping and the calendar operation stops.

With it, an update interrupt event does not occur at an alarm interrupt and the time.

* 2) The part of the fixed-cycle timer interrupt function stops.

A count stops the source clock setting of the timer in case of "64Hz, 1Hz, 1min, 1h".

* 3) Note 3: The effect of STOP bit to FOUT functions.

When STOP = "1", 32768Hz and 1024Hz output is possible.

But 1Hz output is disabled.

* 4) Switchover function cannot work in order that the VDD voltage drop detection stops even if a main power supply falls.

13.3.6. Function-related register 2 (SPI: BANK2 Reg - 0[h] ~ 2[h] / I²C Reg - 30[h] ~ 32[h])

1) BKSON, BKSOFF, BKSMP1, BKSMP0 bit

These are the setting of the MOS switch between VDD - VBAT and setting of the operation mode of the low voltage detect circuit of VDD.

* Please refer to [14.8. Battery Backup switchover function] for the details.

2) FOPIN1, FOPIN0 bit

This bit selects destination (/IRQ1 or /IRQ2) of FOUT.

3) TMPIN bit

This bit selects destination (/IRQ1 or /IRQ2) of fixed-cycle timer function.

4) TMREC bit

The /IRQ1 pin outputs the Fixed-cycle pulse of one period of =1s(Hi-z = 31.25ms) by this bit.

5) IOCUTEN bit

This bit selects whether to stop interface and FOUT /IRQ2 in backup mode.

13.3.7. Reserved bit

The '-' mark has to write in specified fixed value in the case of initialization by all means.

Writing data as follows. *Setting for this frequency tolerance B products.

Address [h]		Function	bit 7	bit 6	bit 5	bit 4	bit 3	bit 2	bit 1	bit 0
SPI	I ² C									
BANK 1										
7	17	Reserved	-	-	-	-	-	-	-	-
		<i>(For tolerance B setting data)</i>	1	0	1	0	1	0	0	0

Address [h]		Function	bit 7	bit 6	bit 5	bit 4	bit 3	bit 2	bit 1	bit 0
SPI	I ² C									
BANK 3										
1	31	Reserved	○	○	○	IOCUT EN	BK SON	BK SOFF	BK SMP1	BK SMP0
		<i>(Setting data)</i>	0	0	0	IOCUT EN	BK SON	BK SOFF	BK SMP1	BK SMP0
2	32	IRQ Control	○	-	-	TMREC	○	TMPIN	FOPIN1	FOPIN0
		<i>(Setting data)</i>	0	0	0	TMREC	0	TMPIN	FOPIN1	FOPIN0

14. How to use

14.1. Clock calendar explanation

At the time of a communication start, the Clock & Calendar data are fixed (hold the carry operation), and it is automatically revised at the time of the communication end. Therefore it recommends that the access to a clock calendar has continuous access by the auto increment function.

Setting example: Sun, 29-Feb-88 17:39:45 (leap year)

Address [h]		Function	bit 7	bit 6	bit 5	bit 4	bit 3	bit 2	bit 1	bit 0
SPI BANK 1	I ² C									
0	10	SEC	0	1	0	0	0	1	0	1
1	11	MIN	0	0	1	1	1	0	0	1
2	12	HOUR	0	0	0	1	0	1	1	1
3	13	WEEK	0	0	0	0	0	0	0	1
4	14	DAY	0	0	1	0	1	0	0	1
5	15	MONTH	0	0	0	0	0	0	1	0
6	16	YEAR	1	0	0	0	1	0	0	0

* Note with caution that writing non-existent time data may interfere with normal operation of the clock counter.

14.1.1. Clock counter

1) [SEC] [MIN] register

These registers are 60-base BCD counters. These registers are incremented at the timing when carry is generated from a lower register. At the timing when the lower register changes from 59 to 00, carry is generated to the higher register and thus incremented.

When writing is performed to [SEC] register, Internal-count-down-chain less than one second (512Hz ~ 1 Hz) is cleared to 0.

2) [HOUR] register

This register is a 24-base BCD counter (24 hour format). These registers are incremented at the timing when carry is generated from a lower register.

14.1.2. Week counter

The day (of the week) is indicated by 7 bits, bit 0 to bit 6.

The day data values are counted as: Day 01h → Day 02h → Day 04h → Day 08h → Day 10h → Day 20h → Day 40h → Day 01h → Day 02h, etc.

It is incremented when carry is generated from the HOUR register. This register does not generate carry to a higher register. Since this register is not connected with the YEAR, MONTH and DAY registers, it needs to be set again with the matching day of the week if any of the YEAR, MONTH or DAY registers have been changed.

The setting example of the week register value.

Day	bit 7	bit 6	bit 5	bit 4	bit 3	bit 2	bit 1	bit 0	Data [h]
Sunday	0	0	0	0	0	0	0	1	01 h
Monday	0	0	0	0	0	0	1	0	02 h
Tuesday	0	0	0	0	0	1	0	0	04 h
Wednesday	0	0	0	0	1	0	0	0	08 h
Thursday	0	0	0	1	0	0	0	0	10 h
Friday	0	0	1	0	0	0	0	0	20 h
Saturday	0	1	0	0	0	0	0	0	40 h

* Do not set "1" to more than one day at the same time.

14.1.3. Calendar counter

1) [DAY], [MONTH] register

The DAY register is a variable (between 28-base and 31-base) BCD counter that is influenced by the month and the leap year. The MONTH register is 12-base BCD counter. when carry is generated from a lower register.

		Jan.	Feb.	Mar	Apr.	May	June	July	Aug.	Sep.	Oct.	Nov.	Dec.
Days	Normal year	31	28	31	30	31	30	31	31	30	31	30	31
	Leap year		29										

2) [YEAR] register

This register is a BCD counter for years 00 to 99.

The leap year is automatically determined, which reflects in the DAY register.

14.2. Fixed-cycle Timer Interrupt Function

The fixed-cycle timer interrupt function generates an interrupt event periodically at any fixed cycle set between 244.14 μs and 65535 hours. This function can stop at one time and is available as an accumulative timer. After the interrupt occurs, the /IRQ status is automatically cleared.

14.2.2. Related registers for function of fixed-cycle timer interrupt function

Address [h]		Function	bit 7	bit 6	bit 5	bit 4	bit 3	bit 2	bit 1	bit 0
SPI BANK 1	I ² C									
B	1B	Timer Counter 0	128	64	32	16	8	4	2	1
C	1C	Timer Counter 1	32768	16384	8192	4096	2048	1024	512	256
D	1D	Extension Register	FSEL1	FSEL0	USEL	TE	WADA	TSEL2	TSEL1	TSEL0
E	1E	Flag Register	○	○	UF	TF	AF	○	VLF	○
F	1F	Control Register	TEST	STOP	UIE	TIE	AIE	TSTP	TBKON	TBKE

Address [h]		Function	bit 7	bit 6	bit 5	bit 4	bit 3	bit 2	bit 1	bit 0
SPI BANK 3	I ² C									
2	32	IRQ Control	○	-	-	TMREC	○	TMPIN	FOPIN1	FOPIN0

- * Before entering operation settings, we recommend first clearing the TE bit to "0" .
- * When the fixed-cycle timer function is not being used, the fixed-cycle Timer Counter0,1 register can be used as a RAM register. In such cases, stop the fixed-cycle timer function by writing "0" to the TE and TIE bits.

1) Down counter for fixed-cycle timer (Timer Counter 1, 0)

This register is used to set the default (preset) value for the counter. Any count value from 1 (0001 h) to 65535 (FFFFh) can be set.

Be sure to write "0" to the TE bit before writing the preset value.

- * When TE=0, read out data of timer counter is default(Preset) value.
- And when TE=1, read out data of timer counter is just counting value.
- But, when access to timer counter data, counting value is not held.
- Therefore, for example, perform twice read access to obtain right data, and a way to adopt the case that two data accorded is necessary.

2) TSEL2, TSEL1, TSEL0 bit

The combination of these three bits is used to set the countdown period (source clock) for this function.

TSEL2 (bit 2)	TSEL1 (bit 1)	TSEL0 (bit 0)	Source clock	Auto reset time tRTN
0	0	0	4096 Hz /Once per 244.14 μs	122 μs
0	0	1	64 Hz /Once per 15.625 ms	7.813 ms
0	1	0	1 Hz /Once per second	7.813 ms
0	1	1	1/60 Hz /Once per minute	7.813 ms
1	0	0	1/3600 Hz /Once per hour	7.813 ms

- *1) The /IRQ pin's auto reset time (tRTN) varies as shown above according to the source clock setting.
- *2) The first countdown shortens than a source clock.
When selected 4,096Hz / 64HZ / 1Hz as a source clock, one period of error occurs at the maximum.
When selected 1/60Hz / 1/3600Hz as a source clock, 1Hz of error occurs at the maximum.

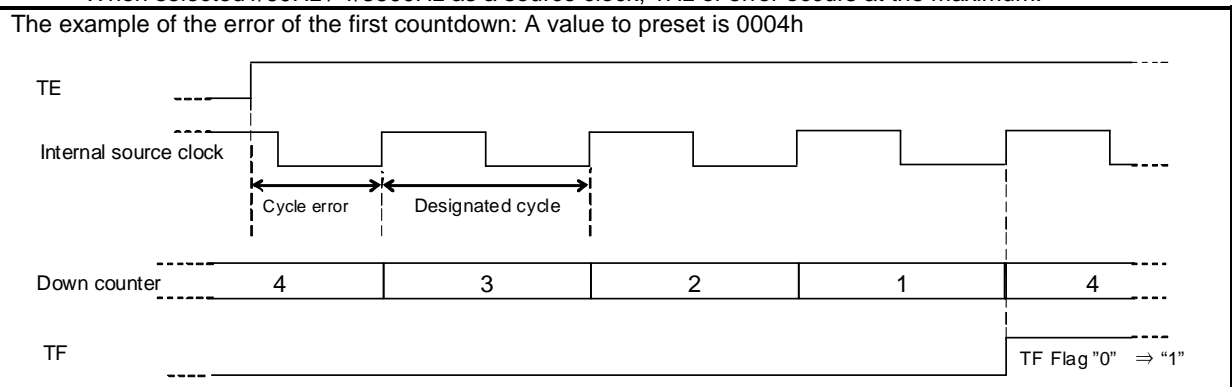

Inside counter block diagram

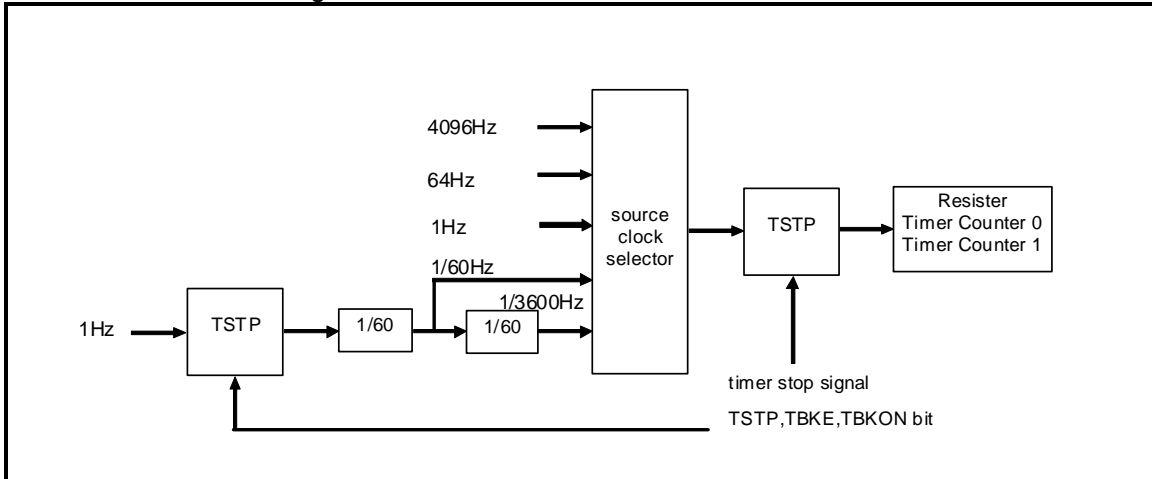

* Cannot read the count value that is lower than a selected source clock.

3) TE bit (Timer Enable)

When TE bit is "0", the default (preset) can be checked by reading this register.

TE	Data	Description
Write	0	Stops fixed-cycle timer interrupt function. * Clearing this bit to zero does not enable the /IRQ low output status to be cleared (to Hi-z).
	1	Starts fixed-cycle timer interrupt function. * The countdown that starts when the TE bit value changes from "0" to "1" always begins from the preset value.

4) TF bit (Timer Flag)

This is a flag bit that retains the result when a fixed-cycle timer interrupt event is detected.

TF	Data	Description
Write	0	The TF bit is cleared to zero to prepare for the next status detection * Clearing this bit to zero does not enable the /IRQ low output status to be cleared (to Hi-z).
	1	This bit is invalid after a "1" has been written to it.
Read	0	-
	1	Fixed-cycle timer interrupt events are detected. (Result is retained until this bit is cleared to zero.)

5) TIE bit (Timer Interrupt Enable)

This bit is used to control output of interrupt signals from the /IRQ1 or /IRQ2 pin when a fixed-cycle timer interrupt event has occurred.

TIE	Data	Description
Write	0	1) When a fixed-cycle timer interrupt event occurs, an interrupt signal is not generated. 2) When a fixed-cycle timer interrupt event occurs, the interrupt signal is canceled (/IRQ status changes from low to Hi-z).
	1	When a fixed-cycle timer interrupt event occurs, an interrupt signal is generated (/IRQ status changes from Hi-z to low).

6) TBKON, TBKE bit

This function selects the operation time with the main power supply or the operation time with the backup power supply. The count value is added.

operation	TBKE	TBKON	Description
Write	0	X	This setting counts normal mode and backup mode.
	1	0	This setting counts it at time of normal mode(VDD ≥ VDET-)
		1	This setting counts it at time of backup mode (VBAT operation)

7) TSTP bit (Timer Stop)

This bit is used to stop fixed-cycle timer count down.

operation	STOP	TBKE	TSTP	Description
Write	0	0	0	Writing a "0" to this bit cancels stop status (restarts timer count down). *The reopening value of the countdown is a stopping value
			1	Count stops.
	1	1	X	Setting of TSTP value becomes invalid, and the count does not stop even if set it in TSTP="1".
		X	X	The count stops at the time of the setting of 64Hz, 1Hz, 1/60Hz, 1/3600Hz.

8) TMPIN bit

Select the destination of the timer interrupt output signal.(/IRQ1 or /IRQ2)

TMPIN	Data	Description
Write	0	/IRQ2 pin
	1	/IRQ1 pin

14.2.3. Fixed-cycle timer start timing

SPI setting

Counting down of the fixed-cycle timer value starts at the rising edge of the CLK signal that occurs when the TE value is changed from "0" to "1".

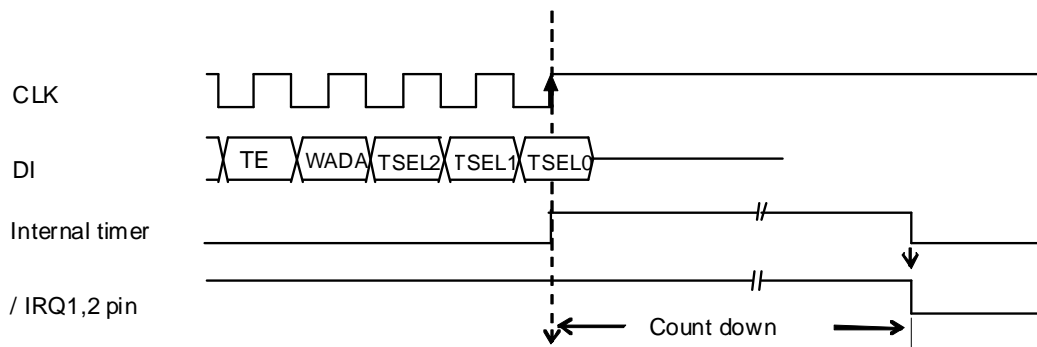

I²C setting

Counting down of the fixed-cycle timer value starts at the rising edge of the SCL (ACK output) signal that occurs when the TE value is changed from "0" to "1".

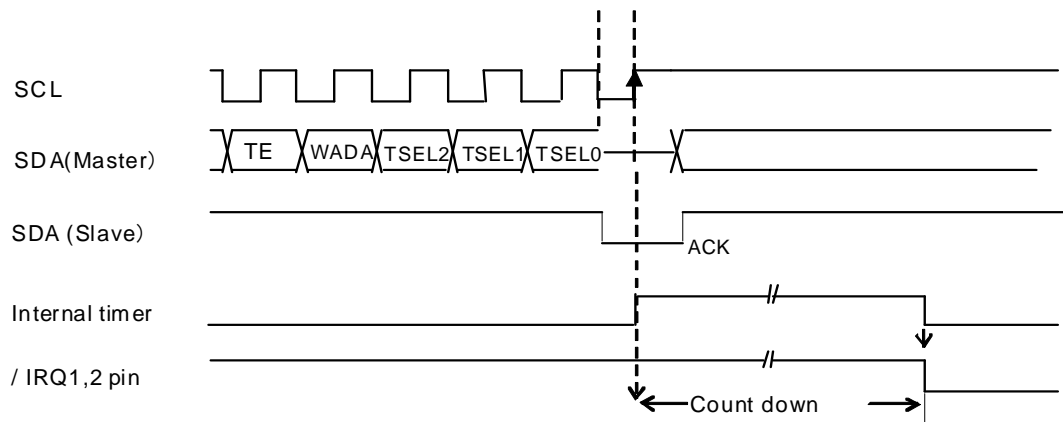

14.2.4. Fixed-cycle timer interrupt interval (example)

The combination of the source clock settings and fixed-cycle timer countdown setting sets interrupt interval, as shown in the following examples.

Timer Counter setting 1 ~ 65535	Source clock				
	4096 Hz TSEL2 = 0 TSEL1, 0 = 0, 0	64 Hz TSEL2 = 0 TSEL1, 0 = 0, 1	1 Hz TSEL2 = 0 TSEL1, 0 = 1, 0	1 / 60 Hz TSEL2 = 0 TSEL1, 0 = 1, 1	1 / 3600 Hz TSEL2 = 1 TSEL1, 0 = 0, 0
0	–	–	–	–	–
1	244.14 μs	15.625 ms	1 s	1 min	1 h
:	:	:	:	:	:
410	100.10 ms	6.406 s	410 s	410 min	410 h
:	:	:	:	:	:
3840	0.9375 s	60.000 s	3840 s	3840 min	3840 h
:	:	:	:	:	:
4096	1.0000 s	64.000 s	4096 s	4096 min	4096 h
:	:	:	:	:	:
65535	15.9998 s	1023.984 s	65535 s	65535 min	65535 h

14.2.5. Diagram of fixed-cycle timer interrupt function

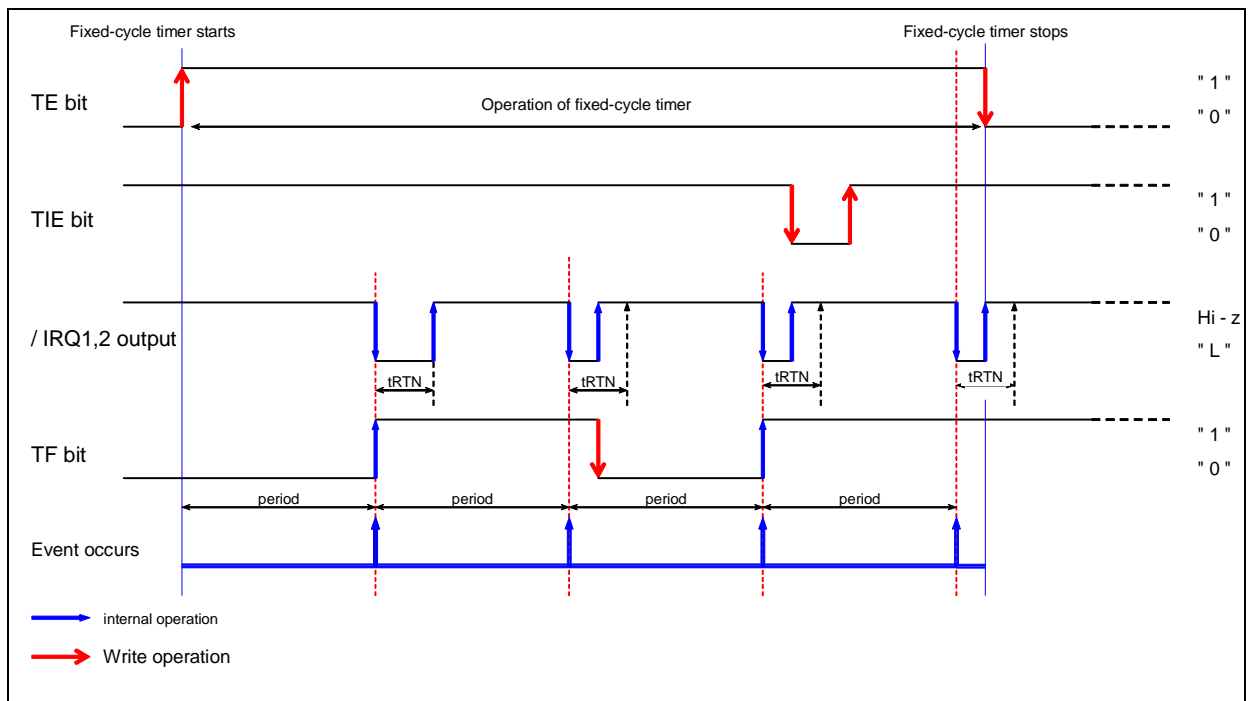

- * After the interrupt event that occurs when the count value changes from 0001h to 0000h, the counter automatically reloads the preset value and again starts to count down. (Repeated operation)
- * The count down that starts when the TE bit value changes from "0" to "1" always begins from the preset value.

14.3. Alarm Interrupt Function

The alarm interrupt function generates interrupt events for alarm settings such as date, day, hour, and minute settings.

When an interrupt event occurs, the AF bit value is set to "1" and the /IRQ1 pin goes to low level to indicate that an event has occurred. AF bit and IRQ output change after 1.46ms from alarm agreement at the maximum.

* /IRQ1="L" output when occurs alarm interruption event is not cancelled automatically unless giving intentional cancellation and /IRQ1="L" is maintained.

14.3.1. Related registers for Alarm interrupt functions.

Address [h]		Function	bit 7	bit 6	bit 5	bit 4	bit 3	bit 2	bit 1	bit 0
SPI BANK 1	I ² C									
8	18	MIN Alarm	AE	40	20	10	8	4	2	1
9	19	HOUR Alarm	AE	•	20	10	8	4	2	1
A	1A	WEEK Alarm	AE	6	5	4	3	2	1	0
		DAY Alarm		•	20	10	8	4	2	1
D	1D	Extension Register	FSEL1	FSEL0	USEL	TE	WADA	TSEL2	TSEL1	TSEL0
E	1E	Flag Register	○	○	UF	TF	AF	○	VLF	○
F	1F	Control Register	<u>TEST</u>	STOP	UIE	TIE	AIE	TSTP	TBKON	TBKE

- * Before entering settings for operations, we recommend writing a "0" to the AIE bit to prevent hardware interrupts from occurring inadvertently while entering settings.
- * When the STOP bit value is "1" alarm interrupt events do not occur.
- * When the alarm interrupt function is not being used, the Alarm registers can be used as a RAM register. In such cases, be sure to write "0" to the AIE bit.
- * Even if use alarm register as RAM register, inside of RTC is processed as alarm setting, therefore it is able to prevent unintentional alarm occurrence (/IRQ1="L" occurrence) due to unexpected agreement with writing data and timer condition by means of setting to AIE="0".

1) Alarm registers

In the WEEK alarm /Day alarm register (Reg - 0A), the setting selected via the WADA bit determines whether WEEK alarm data or DAY alarm data will be set. If WEEK has been selected via the WADA bit, multiple days can be set (such as Monday, Wednesday, Friday, Saturday).

- *1) The register that "1" was set to "AE" bit, doesn't compare alarm.
(Example) Write 80h (AE = "1") to the WEEK Alarm /DAY Alarm register (Reg - 0A):
Only the hour and minute settings are used as alarm comparison targets. The week and date settings are not used as alarm comparison targets.
As a result, alarm occurs if only an hour and minute accords with alarm data.
- *2) If all three AE bit values are "1" the week/date settings are ignored and an alarm interrupt event will occur once per minute.
- *3) Even if the current date/time is used as the setting, the alarm will not occur until the counter counts up to the current date/time (i.e., an alarm will occur next time, not immediately).

2) WADA bit (Week Alarm / Day Alarm Select)

The alarm interrupt function uses either "Day" or "Week" as its target. The WADA bit is used to specify either WEEK or DAY as the target for alarm interrupt events.

WADA	Data	Description
Write	0	Sets WEEK as target of alarm function
	1	Sets DAY as target of alarm function

3) AF bit (Alarm Flag)

When this flag bit value is already set to "0", occurrence of an alarm interrupt event changes it to "1". When this flag bit value is "1", its value is retained until a "0" is written to it.

AF	Data	Description
Write	0	Clearing this bit to zero enables /IRQ1 low output to be canceled (/IRQ1 remains Hi-z) when an alarm interrupt event has occurred.
	1	This bit is invalid after a "1" has been written to it.
Read	0	-
	1	Alarm interrupt events are detected. (Result is retained until this bit is cleared to zero.)

4) AIE bit (Alarm Interrupt Enable)

This bit is used to control output of interrupt signals from the /IRQ1 pin when an Alarm interrupt event has occurred.

AIE	Data	Description
Write	0	1) When an alarm interrupt event occurs, an interrupt signal is not generated or is canceled (/IRQ1 status remains Hi-z). 2) When an alarm interrupt event occurs, the interrupt signal is canceled (/IRQ1 status changes from low to Hi-z).
	1	When an alarm interrupt event occurs, an interrupt signal is generated (/IRQ1 status changes from Hi-z to low).

*The AIE bit is only output control of the /IRQ terminal. It is necessary to clear an AF flag to cancel alarm.

14.3.2. Examples of alarm settings

1) Example of alarm settings when "WEEK" has been specified (and WADA bit = "0")

Day is specified WADA bit = "0"	WEEK Alarm								HOUR Alarm	MIN Alarm
	bit 7 AE	bit 6 S	bit 5 F	bit 4 T	bit 3 W	bit 2 T	bit 1 M	bit 0 S		
Monday through Friday, at 7:00 AM * Minute value is ignored	0	0	1	1	1	1	1	0	07 h	AE bit = 1
Every Saturday and Sunday, for 30 minutes each hour * Hour value is ignored	0	1	0	0	0	0	0	1	AE bit = 1	30 h
Every day, at 6:59 AM	0	1	1	1	1	1	1	1	18 h	59 h
	1	X	X	X	X	X	X	X		

X: Don't care

2) Example of alarm settings when "Day" has been specified (and WADA bit = "1")

Day is specified WADA bit = "1"	Day Alarm								HOUR Alarm	MIN Alarm
	bit 7 AE	bit 6 •	bit 5 20	bit 4 10	bit 3 08	bit 2 04	bit 1 02	bit 0 01		
First of each month, at 7:00 AM * Minute value is ignored	0	0	0	0	0	0	0	1	07 h	AE bit = 1
15 th of each month, for 30 minutes each hour * Hour value is ignored	0	0	0	1	0	1	0	1	AE bit = 1	30 h
Every day, at 6:59 PM	1	X	X	X	X	X	X	X	18 h	59 h

X: Don't care

14.3.3. Diagram of alarm interrupt function

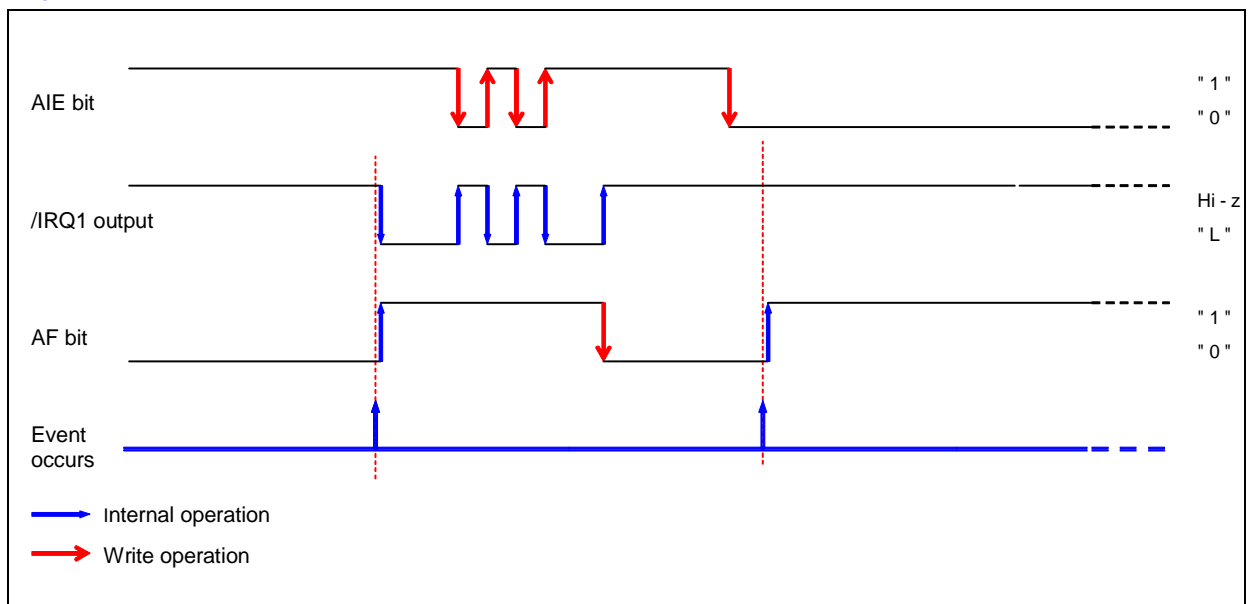

14.4. Time Update Interrupt Function

The time update interrupt function generates interrupt events at one-second or one-minute intervals, according to the timing of the internal clock. This /IRQ1 status is automatically cleared (/IRQ1 status changes from low level to Hi-z 7.813ms after the interrupt occurs).

14.4.1. Related registers for time update interrupt functions.

Address [h]		Function	bit 7	bit 6	bit 5	bit 4	bit 3	bit 2	bit 1	bit 0
SPI BANK 1	i ² C									
D	1D	Extension Register	FSEL1	FSEL0	USEL	TE	WADA	TSEL2	TSEL1	TSEL0
E	1E	Flag Register	○	○	UF	TF	AF	○	VLF	○
F	1F	Control Register	<i>TEST</i>	STOP	UIE	TIE	AIE	TSTP	TBKON	TBKE

- * Before entering settings for operations, we recommend writing a "0" to the UIE bit to prevent hardware interrupts from occurring inadvertently while entering settings.
- * When the STOP bit value is "1" time update interrupt events do not occur.
- * Although the time update interrupt function cannot be fully stopped, if "0" is written to the UIE bit, the time update interrupt function can be prevented from changing the /IRQ1 pin status to low.

1) USEL bit (Update Interrupt Select)

This bit is used to select "second" update or "minute" update as the timing for generation of time update interrupt events.

USEL	Data	Description
Write	0	Selects "second update" (once per second) as the timing for generation of interrupt events
	1	Selects "minute update" (once per minute) as the timing for generation of interrupt events

2) UF bit (Update Flag)

This flag bit value changes from "0" to "1" when a time update interrupt event occurs.

UF	Data	Description
Write	0	Clearing this bit to zero enables /IRQ1 low output to be canceled (/IRQ1 remains Hi-z) when an time update interrupt event has occurred.
	1	This bit is invalid after a "1" has been written to it.
Read	0	-
	1	Time update interrupt events are detected. (The result is retained until this bit is cleared to zero.)

3) UIE bit (Update Interrupt Enable)

This bit selects whether to generate an interrupt signal or to not generate it.

UIE	Data	Description
Write / Read	0	1) Does not generate an interrupt signal. (/IRQ1 remains Hi-z) 2) Cancels interrupt signal triggered by time update interrupt event (/IRQ1 changes from low to Hi-z).
	1	When an Update interrupt event occurs, an interrupt signal is generate.

14.4.2. Time update interrupt function diagram

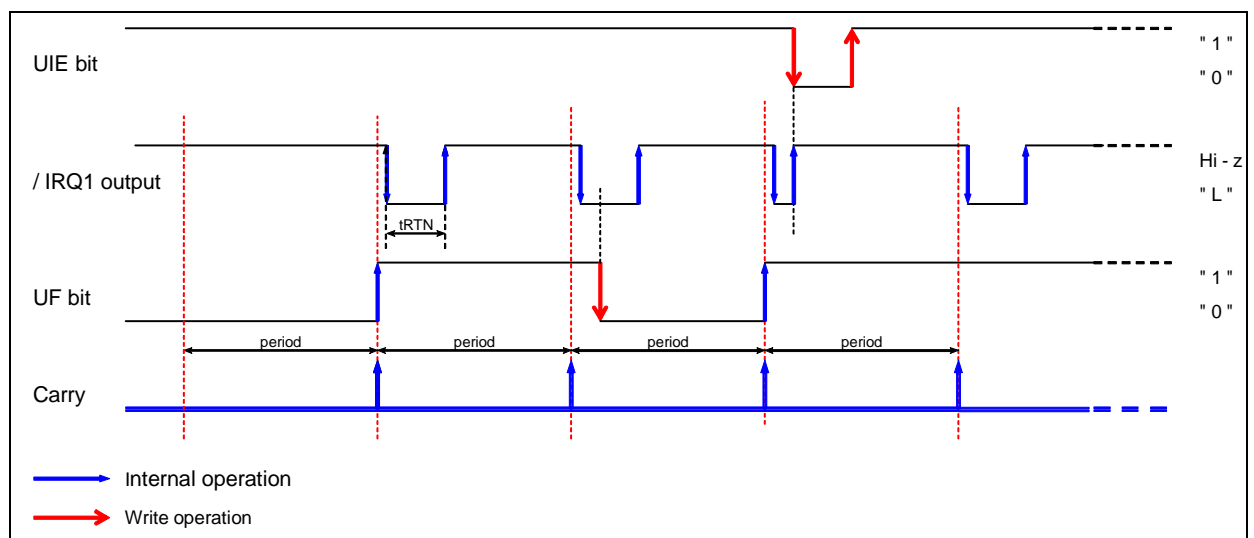

14.5. Frequency stop detection function

This flag bit indicates the retained status of clock operations or internal data. Its value changes from "0" to "1" when data loss occurs, such as due to a supply voltage drop. Once this flag bit's value is "1", its value is retained until a "0" is written to it. This function cannot detect a instantaneous voltage drop .
 During the initial power-on (from 0 V) and if the value of the VLF bit is "1" when the VLF bit is read, be sure to initialize all registers before using them.

14.5.1. Related registers for Frequency stop detection function and Voltage low detection function.

Address [h]		Function	bit 7	bit 6	bit 5	bit 4	bit 3	bit 2	bit 1	bit 0
SPI	I ² C									
BANK 1										
E	1E	Flag Register	○	○	UF	TF	AF	○	VLF	○

1) VLF bit

VLF	Data	Description
Write	0	The VLF is cleared to 0, and waiting for next low voltage detection.
	1	It is impossible to write in 1 to VLF.
Read	0	RTC register data are valid.
	1	RTC register data are invalid. Should be initialized of all register data. VLF is maintained till it is cleared by zero.

14.6. 1Hz output function

It is a function to output a fixed cycle pulse of 1 second.
The destination is a /IRQ1 pin. It is 31.25 ms for the Hi-z period.

14.6.1. Related registers for 1Hz output function.

Address [h]		Function	bit 7	bit 6	bit 5	bit 4	bit 3	bit 2	bit 1	bit 0
SPI	I ² C									
BANK 3										
2	32	IRQ Control	○	-	-	TMREC	○	TMPIN	FOPIN1	FOPIN0

1) TMREC bit

TMREC	Data	Description
Write	0	Disable a 1Hz output function.
	1	Enable a 1Hz output function.

14.7. FOUT function [clock output function]

The clock signal can be output via the DO/FOUT, /IRQ1, /IRQ2 pin.
When stopped the DO/FOUT, /IRQ2 pin output, the pin becomes the Hi-z.

14.7.1. FOUT control register.

Address [h]		Function	bit 7	bit 6	bit 5	bit 4	bit 3	bit 2	bit 1	bit 0
SPI	I ² C									
BANK 1										
D	1D	Extension Register	FSEL1	FSEL0	USEL	TE	WADA	TSEL2	TSEL1	TSEL0

Address [h]		Function	bit 7	bit 6	bit 5	bit 4	bit 3	bit 2	bit 1	bit 0
SPI	I ² C									
BANK 3										
2	32	IRQ Control	○	-	-	TMREC	○	TMPIN	FOPIN1	FOPIN0

By a combination of FSEL1,FSEL0 and CE/FOE pin, an FOUT outputs 32768Hz and 1024Hz and 1Hz and can stop the output.

14.7.2. FOUT function table.

FOUT output pin layout

SPISELpin	FOPIN1	FOPIN0	Output pin	Output on the backup
L	0	0	/IRQ2	OFF(Hi-z)
	0	1	/IRQ1	Enable
	1	X	DO/FOUT	OFF(Hi-z)
H	0	0	/IRQ2	OFF(Hi-z)
	0	1	/IRQ1	Enable
	1	X	Do not output	-

2) FSEL1,FSEL0 bit

CE/FOE pin I ² C setting	FSEL1	FSEL0	output
" L "	0	0	OFF
	0	1	1 Hz Output
	1	0	1024 Hz Output
	1	1	32768 Hz Output Do not set it in /IRQ2
" H "	0	0	32768 Hz Output (DO/FOUT)

X: don't care

- * At the time of the initial power-on, "0" is set to FSEL1, FSEL0.
- * At initial power-on, in case of CE/FOE input is high, 32768Hz is selected automatically and output from DO/FOUT pin by power-on-reset-function.(I²C setting)

Note: The effect of STOP bit to FOUT functions.
When STOP = "1", 32768Hz output is possible.
But 1Hz and 1024Hz output is disabled.

14.8. Battery backup switchover function

14.8.1. Description of Battery backup switchover function

It consists of the power-source detector "VDET" which detect the power down of the main power source "VDD", and built-in MOS switches located between the main power-source pin "VDD" and the backup power supply pin "VBAT".

In turning off a MOS switch according to the supply-voltage detection result of VDET, when an drive power source changes to VDD OFF ->VBAT (it shifts to a backup operation from a normal operation), it becomes possible to prevent a reverse-current (VBAT->VDD) of an electric current.

At the time of a backup operation, "DO/FOUT and /IRQ2" pin becomes Hi-z, and signal of serial-data input pin does not transmit inside, so floating of a pin is permitted.

To not use this function, it's necessary to fix VDD pin to VBAT.

14.8.2. Related register of Battery backup switchover function

Address [h]		Function	bit 7	bit 6	bit 5	bit 4	bit 3	bit 2	bit 1	bit 0
SPI BANK 3	I ² C									
1	31	Reserved	○	○	○	IOCUT EN	BK SON	BK SOFF	BK SMP1	BK SMP0

1) BKSON, BKSOFF bit

MOS-Switch is controlled by these bits.

operation	BKSON	BKSOFF	Description
Write	0	0	In the case of using a backup circuitry. Default
	0	1	In the case of using a primary cell for a backup power.
	1	0	In the case of using a primary cell for a backup power supply. It is necessary to fix VDD to VBAT. This set does not perform a power-down detection of VDD. Even if VDD becomes less than 1.6V, neither an interface and FOUT output is turned off automatically.
	1	1	In the case of using a backup circuitry. The consumption electric current at the time of a normal operation can be lessened more by set of BKSON=0 and BKSOFF=0.

By power-on reset at the time of initial power-on, the initial state is set to MOS switch ON, BKSON = BKSOFF = 0. When implementing a backup battery first while the voltage VDD is not applied, the VDD voltage monitoring is operating and automatically MOS switch is turned OFF when the voltage of VDD is detected below VDET-.

2) BKSMP1, BKSMP0 bit

The time of the VDD voltage monitoring and the turning off time of MOS-Switch for the VDD voltage monitoring are set by these bits. When RTC monitor the voltage, MOS-Switch becomes OFF, and discharge of VDD is cut off from VBAT, and VDD discharges electricity.

BKSMP1	BKSMP0	Monitor time	Comment
0	0	2 ms	Default
0	1	16 ms	
1	0	128 ms	
1	1	256 ms	

Operation once in 1000ms.

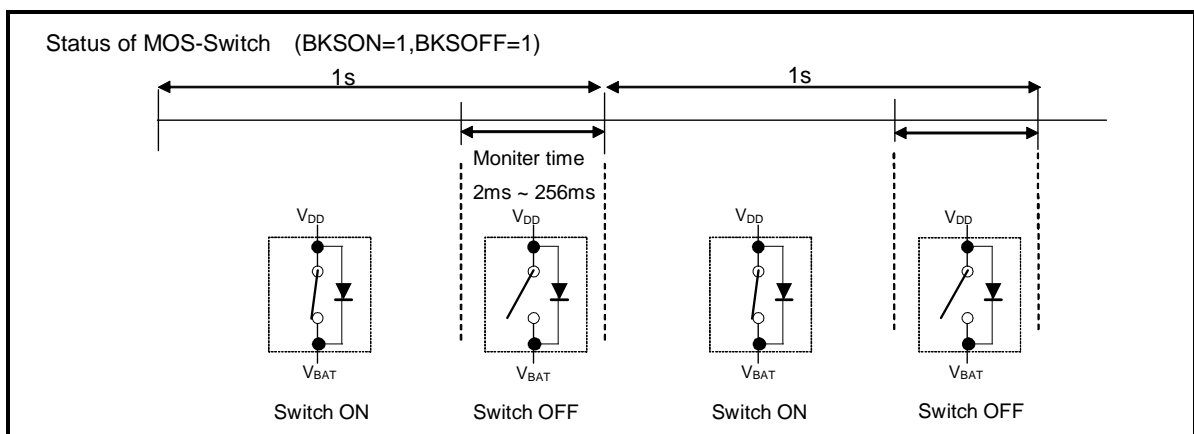

3) Operation list by register setting

BKSON	BKSOFF	BKSMP1	BKSMP0	VDD monitor time		MOS-Switch ON/OFF
				Normal mode	Backup mode	
0	0	0	0	Always ON	Intermittent ON 2ms	Intermittent OFF 2ms
		0	1	Always ON		Intermittent OFF 16ms
		1	0	Always ON		Intermittent OFF 128ms
		1	1	Always ON		Intermittent OFF 256ms
1	1	0	0	Intermittent ON 2ms	Intermittent ON 2ms	Intermittent OFF 2ms
		0	1	Intermittent ON 16ms		Intermittent OFF 16ms
		1	0	Intermittent ON 128ms		Intermittent OFF 128ms
		1	1	Intermittent ON 256ms		Intermittent OFF 256ms
0	1	0	0	Intermittent ON 2ms	Intermittent ON 2ms	Always OFF
		0	1	Intermittent ON 16ms		Always OFF
		1	0	Intermittent ON 128ms		Always OFF
		1	1	Intermittent ON 256ms		Always OFF
1	0	1	1	Always OFF	Always OFF	Always ON

- 1) MOS-Switch when backup is always OFF.
- 2) Intermittent period: Normal mode Once /1s
Backup mode Once / 31.25ms

4) Block diagram

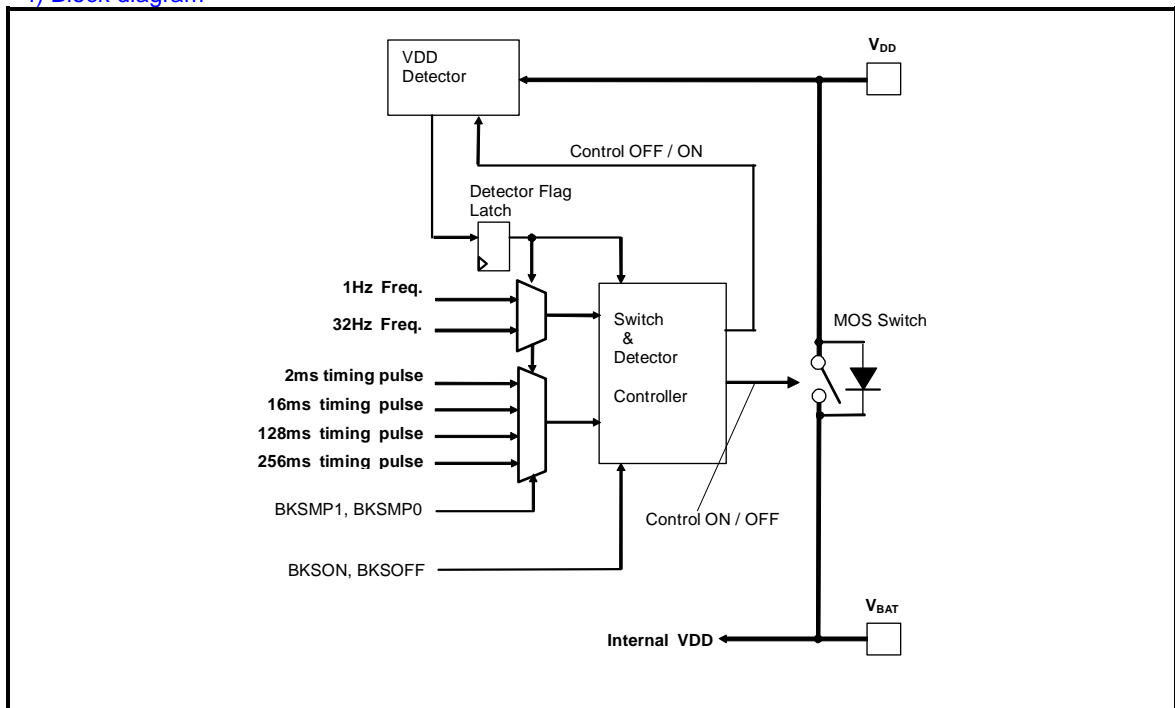

5) IOCUTEN

This bit selects whether to stop I/O (Interface, DO/FOUT, /IRQ2) in backup mode. I/O automatically stop when it become to the backup mode by detecting (VDET-) a VDD voltage drop.

IOCUTEN	Data	Description
Write	0	Do not control I/O.
	1	Stop I/O at the time of backup mode.

When inside crystal oscillation stops, it is "0" cleared automatically. Therefore cannot set "1" to IOCUTEN bit in a state of a non-oscillation just after initial power-on.

14.9. Digital offset function

The clock precision can be set ahead or behind. The minimum resolution is 3.05×10^{-6} and it can adjust it in the range of $+192.3 \times 10^{-6}$ from -195.3×10^{-6} . **When calculate compensation value from frequency accuracy or clock accuracy, please refer to accuracy after initialized a register by all means.**

14.9.1. Digital offset register

Address [h]		Function	bit 7	bit 6	bit 5	bit 4	bit 3	bit 2	bit 1	bit 0
SPI BANK 3	I ² C									
0	30	Digital offset	DTE	L7	L6	L5	L4	L3	L2	L1

- When DTE="1", the digital offset function is enabled.
When digital offset is enabled, the digital offset register digitally offsets the timekeeper according to the values set for the digital offset register by changing one second of the clock count every 10 seconds. The FOUT of 32.768kHz output does not change because the oscillation frequency of a built-in crystal does not change.
- When disabled digital offset, set to DTE = "0". A value of setting of L7 L1 is arbitrary.
- The relationship of the L7~L1 bit and the digital offset value
When the L7 bit = "0", it is a positive offset, when the L7 bit = "1", it is a negative offset.

Digital offset bits							Offset value ($\times 10^{-6}$)
L7	L6	L5	L4	L3	L2	L1	
0	1	1	1	1	1	1	+192.26
0	1	1	1	1	1	0	+189.21
•							•
•							•
•							•
0	0	0	0	0	1	0	+6.10
0	0	0	0	0	0	1	+3.05
0	0	0	0	0	0	0	± 0.00
1	1	1	1	1	1	1	-3.05
1	1	1	1	1	1	0	-6.10
•							•
•							•
•							•
1	0	0	0	0	0	1	-192.26
1	0	0	0	0	0	0	-195.31

The offset value is shift value for internal real crystal frequency.

- How to calculate the offset value

1) When the offset value is positive:

$$L [7 \sim 1] = [\text{Offset Value}] / 3.05 \quad \text{However, decimals are discarded.}$$

Example calculation: When the offset value is $+192 \times 10^{-6}$
 $L[7 \sim 1] = 192.26 / 3.05 = 63 \text{ (dec)}$
 $= 0111111 \text{ (bin) is set.}$

2) When the offset value is negative:

$$L [7 \sim 1] = 128 - [\text{Offset Value}] / 3.05 \quad \text{However, decimals are discarded.}$$

Example calculation: When the offset value is -158×10^{-6}
 $L[7 \sim 1] = 128 - (158 / 3.05) = 76 \text{ (dec)}$
 $= 1001100 \text{ (bin) is set.}$

3) When calculate from accuracy of a clock

When adjust 30 seconds in 30 days:

$$\text{Example calculation: } 30 \text{min.} / 2592000 \text{s (30days)} = 11.57 \times 10^{-6}$$

Positive offset

$$L[7 \sim 1] = 11.57 / 3.05 = 4 \text{ (dec) However, decimals are discarded.}$$

$$= 0000100 \text{ (bin) is set.}$$

Negative offset

$$L[7 \sim 1] = 128 - (11.57 / 3.05) = 124 \text{ (dec) However, decimals are discarded.}$$

$$= 1111100 \text{ (bin) is set.}$$

14.9.2. About effect to the other function when used a digital offset function

Because this function adjusts an internal clock, this function affects a Fixed-cycle timer interrupt function and a FOUT function.

1) FOUT function

- 1Hz setting: Once in 10 seconds, a 1Hz period fluctuates.
- 1024Hz setting: Once in 10 seconds, a 1024Hz period fluctuates.
*There is a case that does not change depending on a set content.
- 32.768kHz is not affected.

2) Fixed-cycle timer interrupt function

- 64Hz or 1Hz source clock setting: Once in 10 seconds, a period fluctuates.
When the setting of the down counter is large, the influence looks small relative.
- 4kHz source clock is not affected.

14.10. Flow-chart

The following flow-chart is one instance.

Mention for easy understanding takes precedence over others; therefore there are some inefficient cases for the actual processing. If you wish to take more efficient process, perform some processes at the same time or try to confirm and adjust some part where is no hindered from transposing of operation procedure. (Unnecessary processing may be included in mentioned items according to conditions to use.

To get movement according to your expectation, please surely adjust according to conditions to use (use environment).

1) An example of the initialization

Ex.1 Initialize

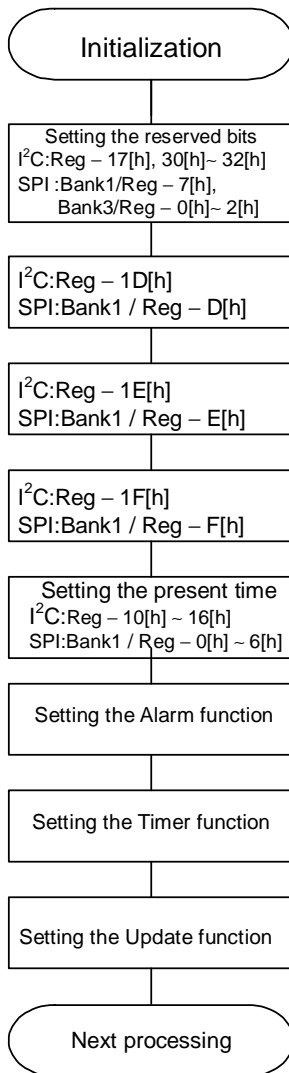

- Reserved bits have to write in specified fixed value in the case of initialization by all means.
 - Set TE bit to "0".
 - Set FSEL1, 0 bit optionally.
 - Clear VLF bit to "0".
State of VLF=1 is held even if it 0 clear until oscillation start. When initialize it without waiting for an oscillation start, Clear VLF bit after an oscillation start. And initialize IOCUTEN bit after an oscillation start.
 - Surely set TEST bit to "0".
 - Set AIE, TIE, UIE bit to "0" to prevent unprepared interruption output.
 - Set the present time.
* Setting the present time concerned, please refer to item of [Clock and calendar writing] .
 - Set the Alarm interrupt function.
When the alarm interrupt function is not being used, the Alarm registers can be used as a RAM register. In such cases, be sure to write "0" to the AIE bit.
 - Set the fixed-cycle Timer function.
When the fixed-cycle timer function is not being used, the Timer Counter register can be used as a RAM register. In such cases, stop the fixed-cycle timer function by writing "0" to the TE and TIE bits.
 - Set the Update interrupt function.
- * When initialization is finished, be sure to set STOP bit to "0".

2) Method of initialization after starting of internal oscillation

The Initialize is possible in 40ms since Internal VDD becomes higher than VDET+. Even in this case, after an internal oscillation begins, it is necessary to clear VLF= "0".

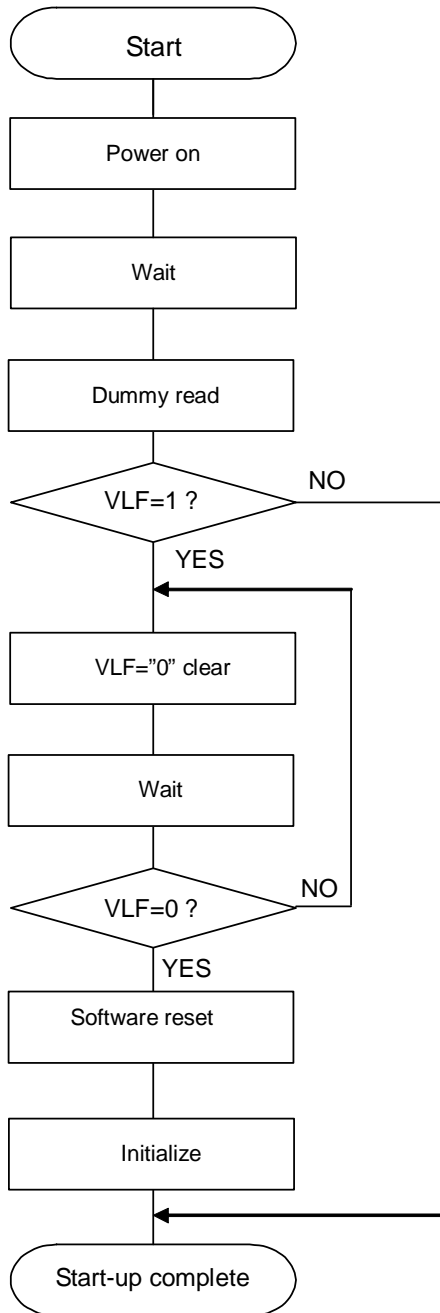

- Wait time of 40ms is necessary at least

- When power-on reset cannot satisfy a power supply condition valid, execute a dummy read. (Only I²C use)

- Whether it is a return from the state of the backup is confirmed.

- When an internal oscillation starts, 0 writing of VLF is approved.

- Please set waiting time depending on load of a system optionally

- When power-on reset cannot satisfy a power supply condition valid, execute a software reset. On the left [software reset], below a " Check VLF bit = "1"" of [P.10 A power-on reset procedure by the software command] procedure corresponds. After software reset, VLF bit is set "1" again.

3) The setting of a clock and calendar

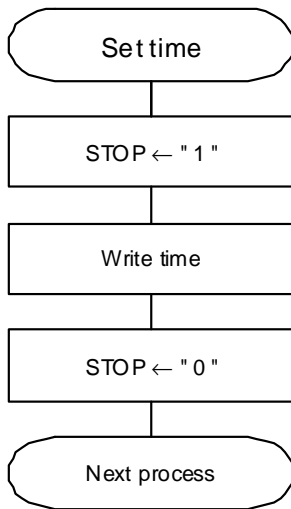

- Set STOP bit to "1" to prevent timer update in time setting.

- Write information of [year / month /date [day of the week] hour: minute: second] which is necessary to set (or reset). In case of initialization, please initialize all data.

- Cancel STOP bit to "0" and start (restart) timer movement. Timer is started when set STOP bit to "0".

* It is able to set time even if not combined use of STOP bit. Please note that [clock is started at the time of writing [second]] in case STOP bit is not used.

4) The reading of a clock and calendar

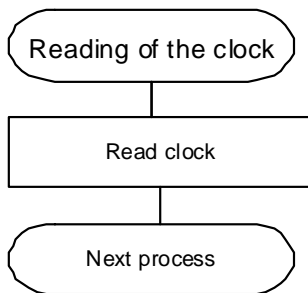

- Please complete access within 0.95 seconds
The STOP bit holds "0".
(It causes the clock delay to set STOP bit to "1")

- At the time of a communication start, the Clock & Calendar data are fixed (hold the carry operation), and it is automatically revised at the time of the communication end.

- The access to a clock calendar recommends to have access to continuation by a auto increment function.

5) The setting example of the fixed-cycle timer interrupt function

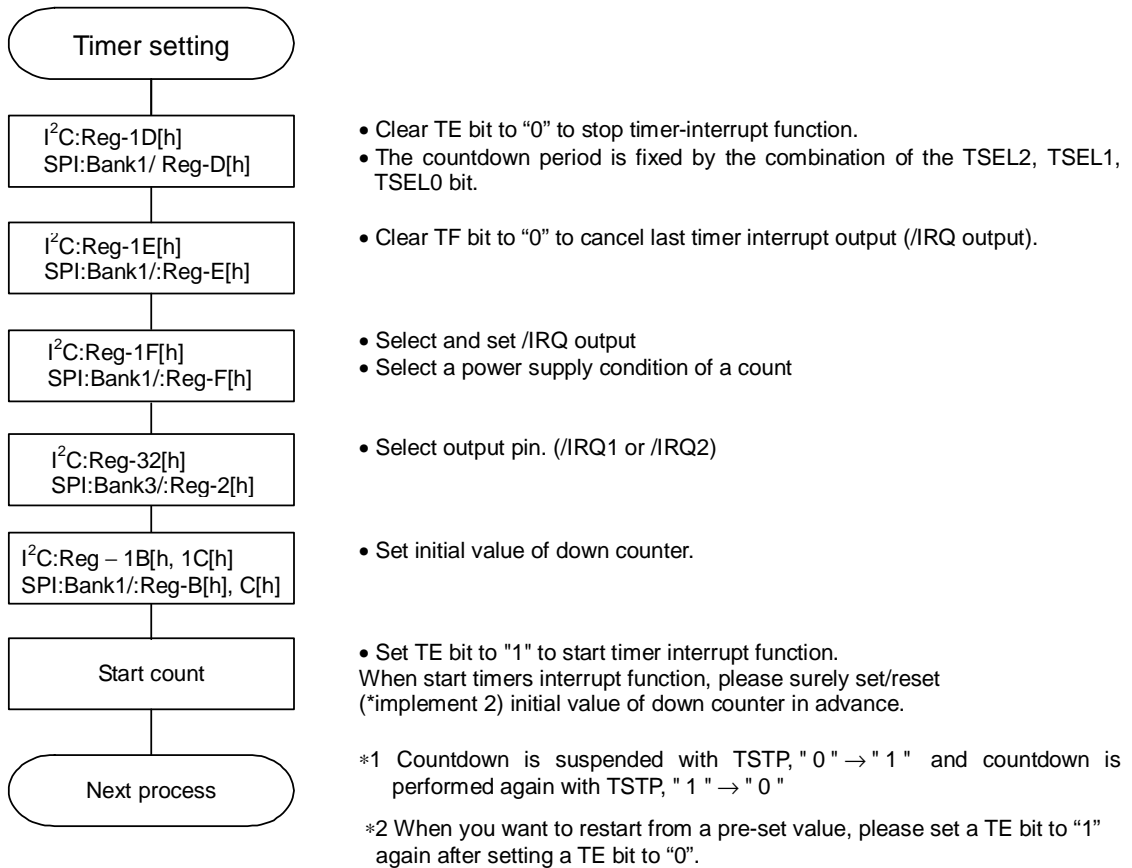

6) The setting example of the Alarm interrupt function

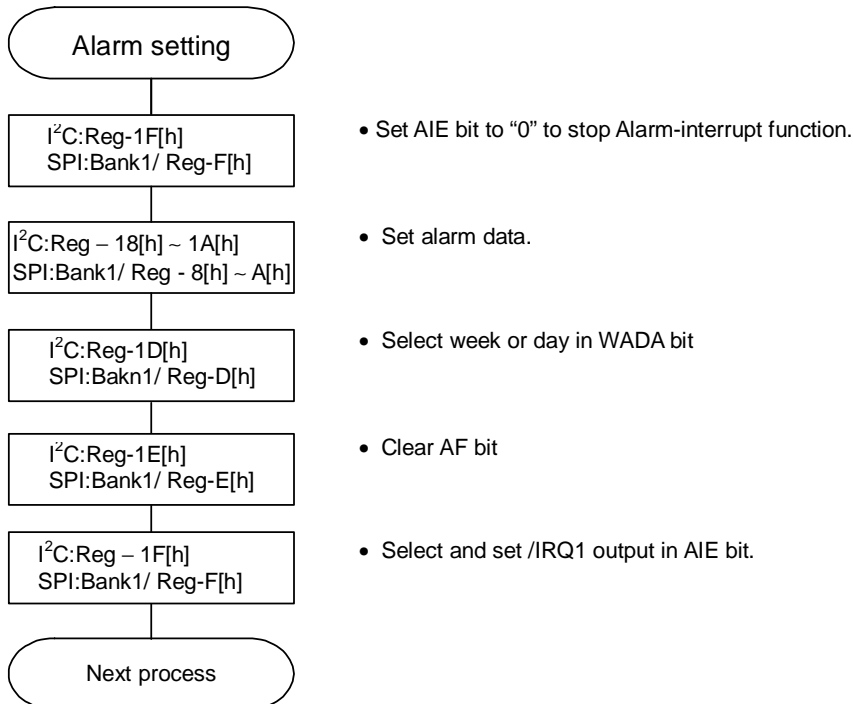

14.11. Reading/Writing Data via the I²C Bus Interface

14.11.1. Overview of I²C-BUS

The I²C bus supports bi-directional communications via two signal lines: the SDA (data) line and SCL (clock) line. A combination of these two signals is used to transmit and receive communication start/stop signals, data transfer signals, acknowledge signals, and so on.

Both the SCL and SDA signals are held at high level whenever communications are not being performed.

The starting and stopping of communications is controlled at the rising edge or falling edge of SDA while SCL is at high level.

14.11.2. Data transfers

Data transfers are performed in 8-bit (1 byte) units once the START condition has occurred. There is no limit on the amount (bytes) of data that are transferred between the START condition and STOP condition. (However, the transfer time must be no longer than 0.95 seconds.)

14.11.3. Starting and stopping I²C bus communications

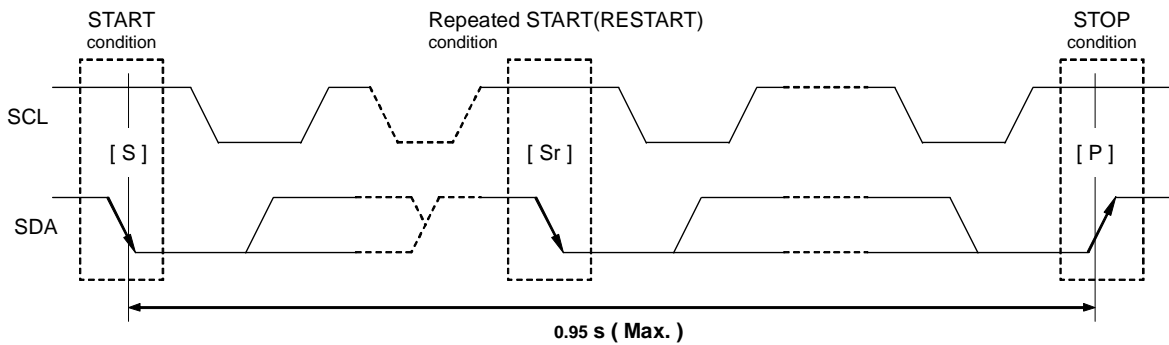

1) START condition, repeated START condition, and STOP condition

(1) START condition

- The SDA level changes from high to low while SCL is at high level.

(2) STOP condition

- This condition regulates how communications on the I²C -BUS are terminated. The SDA level changes from low to high while SCL is at high level.

(3) Repeated START condition (RESTART condition)

- In some cases, the START condition occurs between a previous START condition and the next STOP condition, in which case the second START condition is distinguished as a RESTART condition. Since the required status is the same as for the START condition, the SDA level changes from high to low while SCL is at high level.

14.11.4. Slave address

The I²C-BUS devices do not have any chip select or chip enable pins. All I²C-BUS devices are memorized with a fixed unique number in it. The chip selection on the I²C-BUS is executed, when the interface starts, the master device send the required slave address to all devices on the I²C-BUS. The receiving device only reacts for interfacing, when the required slave address is agreed with its own slave address.

During in actual data transmission, the transmitted data contains the slave address and the data with R/W (read/write) bit.

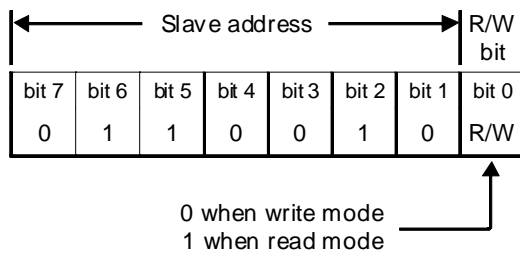

14.11.5. System configuration

All ports connected to the I²C bus must be either open drain or open collector ports in order to enable AND connections to multiple devices.

SCL and SDA are both connected to the V_{IO} line via a pull-up resistance. Consequently, SCL and SDA are both held at high level when the bus is released (when communication is not being performed).

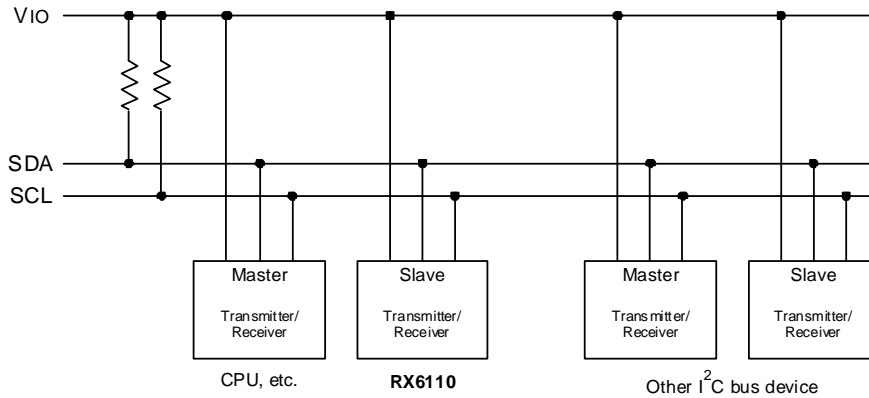

Any device that controls the data transmission and data reception is defined as a "Master".
and any device that is controlled by a master device is defined as a "Slave".

The device transmitting data is defined as a "Transmitter" and the device receiving data is defined as a receiver"

In the case of this RTC module, controllers such as a CPU are defined as master devices and the RTC module is defined as a slave device. When a device is used for both transmitting and receiving data, it is defined as either a transmitter or receiver depending on these conditions.

14.11.6. I²C bus protocol

In the following sequence descriptions, it is assumed that the CPU is the master and the RX6110 is the slave.

1) Address specification write sequence

Since the RX6110 includes an address auto increment function, once the initial address has been specified, the RX6110 increments (by one byte) the receive address each time data is transferred.

- (1) CPU transfers start condition [S].
- (2) CPU transmits the RX6110's slave address with the R/W bit set to write mode.
- (3) Check for ACK signal from RX6110.
- (4) CPU transmits write address to RX6110.
- (5) Check for ACK signal from RX6110.
- (6) CPU transfers write data to the address specified at (4) above.
- (7) Check for ACK signal from RX6110.
- (8) Repeat (6) and (7) if necessary. Addresses are automatically incremented.
- (9) CPU transfers stop condition [P].

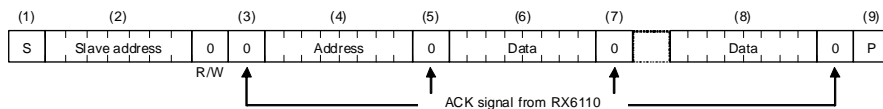

2) Address specification read sequence

After using write mode to write the address to be read, set read mode to read the actual data.

- (1) CPU transfers start condition [S].
- (2) CPU transmits the RX6110's slave address with the R/W bit set to write mode.
- (3) Check for ACK signal from RX6110.
- (4) CPU transfers address for reading from RX6110.
- (5) Check for ACK signal from RX6110.
- (6) CPU transfers RESTART condition [Sr] (in which case, CPU does not transfer a STOP condition [P]).
- (7) CPU transfers RX6110's slave address with the R/W bit set to read mode.
- (8) Check for ACK signal from RX6110 (from this point on, the CPU is the receiver and the RX6110 is the transmitter).
- (9) Data from address specified at (4) above is output by the RX6110.
- (10) CPU transfers ACK signal to RX6110.
- (11) Repeat (9) and (10) if necessary. Read addresses are automatically incremented.
- (12) CPU transfers ACK signal for "1".
- (13) CPU transfers stop condition [P].

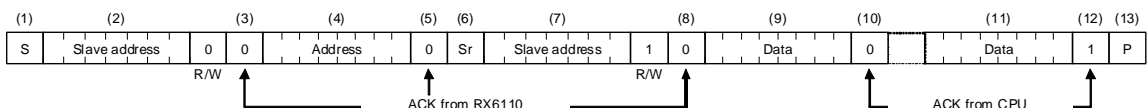

3) Read sequence when address is not specified

Once read mode has been initially set, data can be read immediately. In such cases, the address for each read operation is the previously accessed address + 1.

- (1) CPU transfers start condition [S].
- (2) CPU transmits the RX6110's slave address with the R/W bit set to read mode.
- (3) Check for ACK signal from RX6110 (from this point on, the CPU is the receiver and the RX6110 is the transmitter).
- (4) Data is output from the RX6110 to the address following the end of the previously accessed address.
- (5) CPU transfers ACK signal to RX6110.
- (6) Repeat (4) and (5) if necessary. Read addresses are automatically incremented in the RX6110.
- (7) CPU transfers ACK signal for "1".
- (8) CPU transfers stop condition [P].

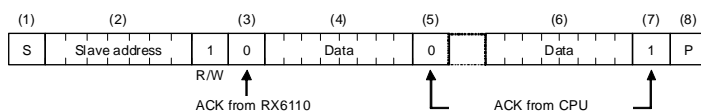

14.12. Reading/Writing Data via the SPI Bus Interface

For both read and write, first set up chip condition (internally CE="H") to CE="H" , then specify the 4-bits address, and finally read or write in 8-bits units. Both read and write use MSB-first. In continuous operation, objected address is auto incremented. Auto incrementing of the address is cyclic, so address "F" is followed by address "0".

14.12.1 Write / Read and Bank Select

R/W and Register bank are specified by the four bits mode setting code.

Mode	Bank1	Bank2	Bank3	Bank6
Read	9 h	A h	B h	Eh
Write	1 h	2 h	3 h	6h

*Bank5 and Bank6 are for software reset

14.12.2 Write of data

1) One-shot writing

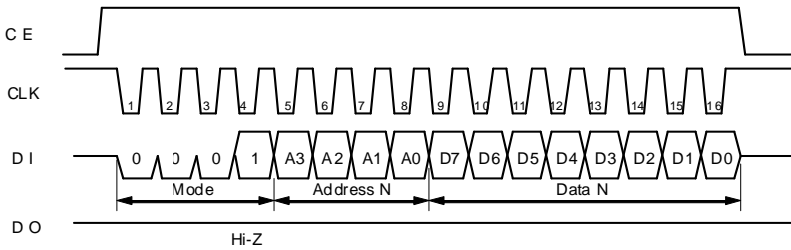

2) Continuous writing

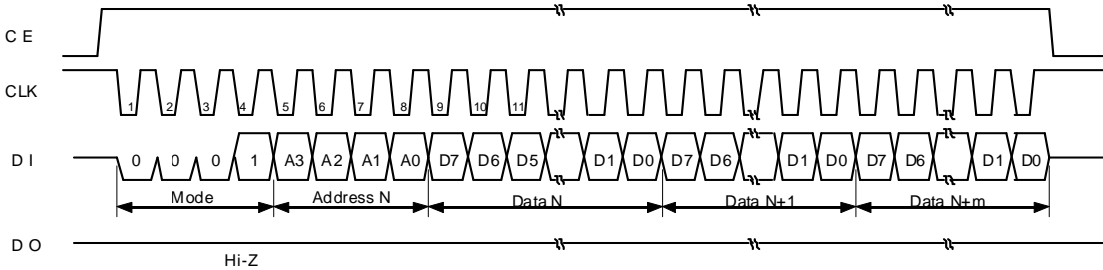

*When writing data, the data needs to be entered in 8-bits units.

If the input of data in 8-bits unit is not completed before CE input falls, the 8-bits data will not be written properly at the time CE input falls.

14.12.3 Read of data

1) One-shot reading

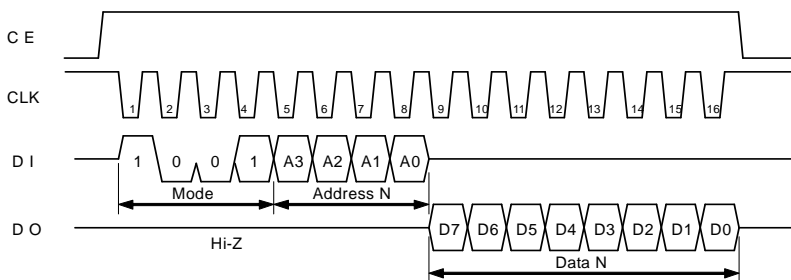

2) Continuous reading

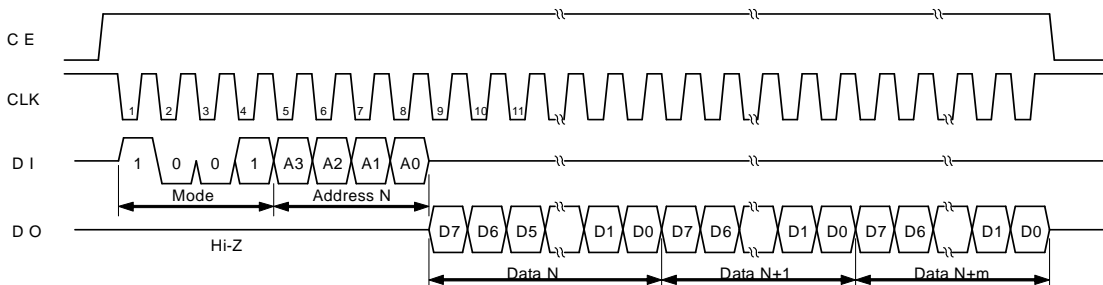

Application Manual

AMERICA

Epson Electronics America, Inc.

Headquarter	214 Devcon Drive, San Jose, CA 95112, U.S.A. Phone: (1)800-228-3964 FAX : (1)408-922-0238 http://www.eea.epson.com
Chicago Office	1827 Walden Office Square, Suite 520 Schaumburg, IL 60173, U.S.A. Phone: (1)847-925-8350 Fax: (1)847 925-8965
El Segundo Office	1960 E. Grand Ave., 2nd Floor, El Segundo, CA 90245, U.S.A. Phone: (1)800-249-7730 (Toll free) : (1)310-955-5300 (Main) Fax: (1)310-955-5400

EUROPE

Epson Europe Electronics GmbH

Headquarter	Riesstrasse 15, 80992 Munich, Germany Phone: (49)-(0)89-14005-0 Fax: (49)-(0)89-14005-110 http://www.epson-electronics.de
-------------	---

ASIA

Epson (China) Co., Ltd.

Headquarter	4F, Tower 1 of China Central Place, 81 Jianguo Street, Chaoyang District, Beijing, 100025 China Phone: (86) 10-8522-1199 Fax: (86) 10-8522-1125 http://www.epson.com.cn/ed/
Shanghai Branch	High-Tech Building,900 Yishan Road Shanghai 200233,China Phone: (86) 21-5423-5577 Fax: (86) 21-5423-4677
Shenzhen Branch	12/F, Dawning Mansion,#12 Keji South Road, Hi-Tech Park,Shenzhen, China Phone: (86) 755-2699-3828 Fax: (86) 755-2699-3838

Epson Hong Kong Ltd.

Unit 715-723 7/F Trade Square, 681 Cheung Sha Wan Road, Kowloon, Hong Kong
Phone: (86) 755-2699-3828 (Shenzhen Branch)
Fax: (86) 755-2699-3838 (Shenzhen Branch)
<http://www.epson.com.hk>

Epson Taiwan Technology & Trading Ltd.

14F, No.7, Song Ren Road, Taipei 110
Phone: (886) 2-8786-6688 Fax: (886)2-8786-6660
<http://www.epson.com.tw/ElectronicComponent>

Epson Singapore Pte. Ltd.

No 1 HarbourFront Place, #03-02 HarbourFront Tower One, Singapore 098633.
Phone: (65)- 6586-5500 Fax: (65) 6271-3182
http://www.epson.com.sg/epson_singapore/electronic_devices/electronic_devices.page

Seiko Epson Corporation Korea Office

19F (63Bldg.,Yoido-dong) 50, 63-ro, Yeongdeungpo-gu, Seoul, 150-763, Korea
Phone: (82) 2-784-6027 Fax: (82) 2-767-3677
<http://www.epson-device.co.kr>

SEIKO EPSON CORPORATION

Distributor

Electronic devices information on WWW server

<http://www5.epsondevice.com/en/>