Application Manual

Real Time Clock Module

RX8900SA CE

ETM45E-10

Product name	Product number
RX8900SA UA ($\pm 3.4 \times 10^{-6}$ / -40°C to $+85^{\circ}\text{C}$)	X1B000292000100
RX8900SA UB ($\pm 5.0 \times 10^{-6}$ / -40°C to $+85^{\circ}\text{C}$)	X1B000292000200
RX8900SA UC ($\pm 5.0 \times 10^{-6}$ / -30°C to $+70^{\circ}\text{C}$)	X1B000292000300
RX8900CE UA ($\pm 3.4 \times 10^{-6}$ / -40°C to $+85^{\circ}\text{C}$)	X1B000301000100
RX8900CE UB ($\pm 5.0 \times 10^{-6}$ / -40°C to $+85^{\circ}\text{C}$)	X1B000301000200
RX8900CE UC ($\pm 5.0 \times 10^{-6}$ / -40°C to $+70^{\circ}\text{C}$)	X1B000301000300

NOTICE : PLEASE READ CAREFULLY BELOW BEFORE THE USE OF THIS DOCUMENT

1. The content of this document is subject to change without notice. Before purchasing or using Epson products, please contact with sales representative of Seiko Epson Corporation ("Epson") for the latest information and be always sure to check the latest information published on Epson's official web sites and resources.
2. This document may not be copied, reproduced, or used for any other purposes, in whole or in part, without Epson's prior consent.
3. Information provided in this document including, but not limited to application circuits, programs and usage, is for reference purpose only. Epson makes no guarantees against any infringements or damages to any third parties' intellectual property rights or any other rights resulting from the information. This document does not grant you any licenses, any intellectual property rights or any other rights with respect to Epson products owned by Epson or any third parties.
4. Using Epson products, you shall be responsible for safe design in your products; that is, your hardware, software, and/or systems shall be designed enough to prevent any critical harm or damages to life, health or property, even if any malfunction or failure might be caused by Epson products. In designing your products with Epson products, please be sure to check and comply with the latest information regarding Epson products (including, but not limited to this document, specifications, data sheets, manuals, and Epson's web site). Using technical contents such as product data, graphic and chart, and technical information, including programs, algorithms and application circuit examples under this document, you shall evaluate your products thoroughly both in stand-alone basis and within your overall systems. You shall be solely responsible for deciding whether to adopt/use Epson products with your products.
5. Epson has prepared this document carefully to be accurate and dependable, but Epson does not guarantee that the information is always accurate and complete. Epson assumes no responsibility for any damages you incurred due to any misinformation in this document.
6. No dismantling, analysis, reverse engineering, modification, alteration, adaptation, reproduction, etc., of Epson products is allowed.
7. Epson products have been designed, developed and manufactured to be used in general electronic applications and specifically designated applications ("Anticipated Purpose"). Epson products are NOT intended for any use beyond the Anticipated Purpose that requires particular quality or extremely high reliability in order to refrain from causing any malfunction or failure leading to critical harm to life and health, serious property damage, or severe impact on society, including, but not limited to listed below ("Specific Purpose"). Therefore, you are strongly advised to use Epson products only for the Anticipated Purpose. Should you desire to purchase and use Epson products for Specific Purpose, Epson makes no warranty and disclaims with respect to Epson products, whether express or implied, including without limitation any implied warranty of merchantability or fitness for any Specific Purpose. Please be sure to contact our sales representative in advance, if you desire Epson products for Specific Purpose: Space equipment (artificial satellites, rockets, etc.) / Transportation vehicles and their control equipment (automobiles, aircraft, trains, ships, etc.) / Medical equipment / Relay equipment to be placed on sea floor / Power station control equipment / Disaster or crime prevention equipment / Traffic control equipment / Financial equipment Other applications requiring similar levels of reliability as the above
8. Epson products listed in this document and our associated technologies shall not be used in any equipment or systems that laws and regulations in Japan or any other countries prohibit to manufacture, use or sell. Furthermore, Epson products and our associated technologies shall not be used for the purposes of military weapons development (e.g. mass destruction weapons), military use, or any other military applications. If exporting Epson products or our associated technologies, please be sure to comply with the Foreign Exchange and Foreign Trade Control Act in Japan, Export Administration Regulations in the U.S.A (EAR) and other export-related laws and regulations in Japan and any other countries and to follow their required procedures.
9. Epson assumes no responsibility for any damages (whether direct or indirect) caused by or in relation with your non-compliance with the terms and conditions in this document or for any damages (whether direct or indirect) incurred by any third party that you give, transfer or assign Epson products.
10. For more details or other concerns about this document, please contact our sales representative.
11. Company names and product names listed in this document are trademarks or registered trademarks of their respective companies.

©Seiko Epson Corporation 2024. All rights reserved.

ETM45E Revision History

Rev No.	Date	Page	Description
ETM45E-01	26.Jan.2015		Release
04	20.Sep.2016	5	I ² C-bus active current
		39	Recommended soldering pattern Optimization of the text
05	14.Oct.2016	24	Add circuit diagram Ex.4 Optimization of the text
		25	8.8.3 Optimization of the text
		26	Optimization of the text
06	12.Jun.2018	13	8.2.7. Control register. Default value was corrected.
		15	5) RESET bit RESET function explanation was updated.
		21	8.5.2. Related registers Address of table was corrected.
07	12.Feb.2019	32	Reference characteristics of Pch-SW and Diode
		11	Block diagram of FOUT,
		21	Block diagram of Timer interruption
		25	Block diagram of Time Update interruption
		27	Block diagram of Alarm interruption
		31 ~ 36	All renewal of 8.8. Battery backup switchover function
		47	Updated Figure of 8.13 Connection example.
48	Note for SA-Package.		
08	10.Apr.2019	6	Updated access time 1 sec (Max.) from 0.95sec.
		33.34	Updated VDD drop detection.
		36	Inserted 8.8.8 Note: Diode characteristics.
09	27.Mar.2024	All	Added link top index and bottom index, to footer.
		All	Updated index of Tables and Figures. Tables Figures
		36	Backup-mode explanation was added in below part. 8.8.5. Disabled functions in backup mode.
		36	Updated reference characteristics. 8.8.5. Reference characteristics of Diode and Pch-Switch.
		36	Add V/I characteristics graph of Diode Figure 19 IF vs VF reference characteristics.
		54	Add note in CE-package drawing. Figure 48 RX8900CE package
10	19.Dec.2024	28	Corrected UF bit function in Time-Update-Interrupt-Function. When UF cleared to zero, even if /INT is LOW in tRTN, /INT return to Hi-Z immediately. Figure 13 Time Update Interrupt Timing Chart.
		29	Table 47 UF bit
		All	The page numbers and PDF page numbers are synchronized.

Note, Past page numbers may have changed due to new revision work.

Contents

ETM45E Revision History	3
Contents	4
1. Overview.....	6
2. Block Diagram	6
3. Terminal description.....	7
3.1. Terminal connections.....	7
3.2. Pin Functions	7
4. Absolute Maximum ratings	8
5. Recommended Operating Conditions	8
6. Frequency Characteristics	9
7. Electrical Characteristics.....	10
7.1 DC characteristics.....	10
7.2. AC Characteristics	11
8. Functions	12
8.1. Description of Registers.....	12
8.1.1. Write / Read and Bank Select.....	12
8.1.2. Register table (Basic time and calendar registers)	12
8.1.3. Temperature Data, Backup power supply control register	14
8.1.4. Quick Reference.....	14
8.2. Details of Registers.....	15
8.2.1. Clock counter SEC - HOUR.....	15
8.2.3. Alarm registers	17
8.2.4. Fixed-cycle timer control registers	17
8.2.5. Extension register.....	18
8.2.7. Control register.....	20
8.2.8. Temperature Data register	22
8.3. Fixed Cycle Timer Interrupt Function.....	23
8.3.2. Related registers for function of time update interrupts	25
8.3.3. Fixed-cycle timer interrupt interval (example).....	27
8.3.4. Fixed-cycle timer start timing	27
8.4. Time Update Interrupt Function	28
8.4.1. Time update interrupt function diagram	28
8.5. Alarm Interrupt Function	30
8.5.1. Diagram of alarm interrupt function	30
8.5.2. Related registers	31
8.5.3. Examples of alarm settings	33
8.6. The interrupt functions via /INT-pin or polling	34
8.7. Temperature compensation function	34
8.7.1. overview	34
8.7.2. Related registers for temperature compensation function	34
8.8. Battery backup switchover function	35
8.8.1. Description of Battery backup switchover function	35
8.8.2. The power switchover control	35
8.8.3. Battery Backup switchover related register	36
8.8.4. Battery Backup switchover related register setting	36
8.8.5. Disabled functions in backup mode.....	36
8.8.5. Reference characteristics of Diode and Pch-Switch	37
8.8.6. Mode flow of the battery backup switchover function	38
8.8.7. The pros and cons of detection period (2msec, 16msec,128msec and 256msec)	39
8.8.8 Note: Diode characteristics.....	42
8.9. Reading/Writing Data via the I ² C Bus Interface	43

RX8900 SA / CE

8.9.1. Overview of I ² C-BUS	43
8.9.2. System configuration	43
8.9.3. Starting and stopping I ² C bus communications	44
8.9.4. Data transfers and acknowledge responses during I ² C-BUS communications.....	45
8.9.5. Slave address.....	45
8.9.6 I ² C bus protocol	46
8.10. Backup and Recovery.....	47
8.11. The note of access to RTC at the time of backup return and initial power supply.....	48
8.12. Flow chart	49
8.13. Connection example with Typical Microcontroller	52
8.14. Connection RTC used as a 32.768 kHz TCXO.....	52
9. External Dimensions Marking Layout	53
9.1. RX8900SA.....	53
9.1.1. External dimensions	53
9.1.2. RX8900SA Marking layout	53
9.2.RX8900CE.....	54
9.2.1 External Dimensions.....	54
9.2.2. Marking layout	54
10 Application Notes	55
11 Tables.....	56
12 Figures.....	57
Contacts	58

I²C-Bus Interface Real-time Clock Module

RX8900 SA / CE

- Features built-in 32.768 kHz DTCXO.
- Supports I²C-Bus's high-speed mode (Up to 400 kHz)
- Alarm interrupt function for day, date, hour, and minute settings
- Wakeup timer interruption
- Time update interrupt function (Seconds, minutes)
- Temperature compensated 32.768 kHz output with OE function (FOE and FOUT pins)
- Auto correction of leap years 2100 is a normal year, but counted as a leap year
- Wide interface voltage range: 2.5 V to 5.5 V
- Wide time-keeping voltage range: 1.6 V to 5.5 V
- Low current consumption: 0.70μA / 3 V Typ.
- Built-in Backup switchover circuit.

1. Overview

This module is an I²C bus interface-compliant real-time clock which includes a 32.768 kHz DTCXO. In addition to providing a calendar (year, month, date, day, hour, minute, second) function and a clock counter function, this module provides an abundance of other functions including an alarm function, Wakeup timer function, time update interrupt function, and 32.768 kHz output function. By the battery backup switchover function and the interface power supply input pin, RX8900 can support various power supply circuitries. The devices in this module are fabricated via a C-MOS process for low current consumption, which enables long-term battery back-up.

2. Block Diagram

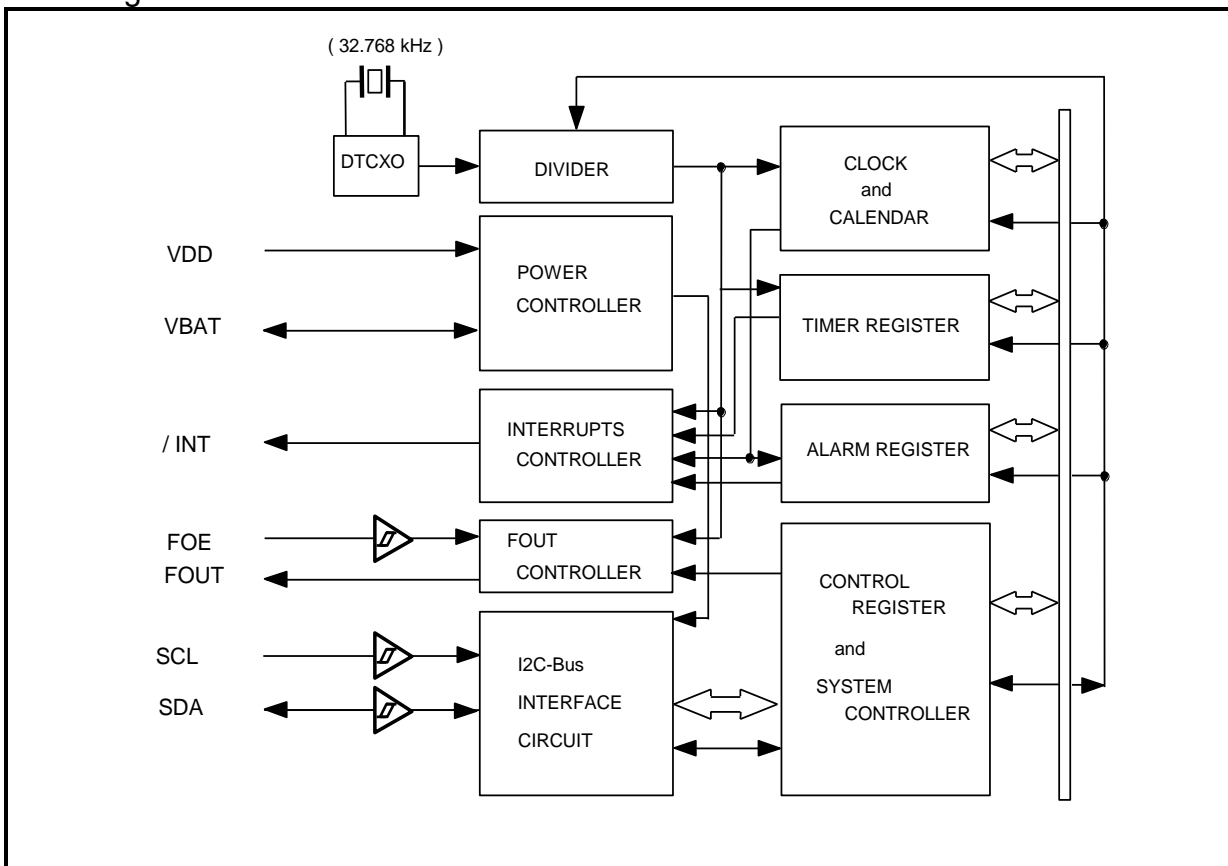

Figure 1 Block Diagram

RX8900 SA / CE

3. Terminal description

3.1. Terminal connections

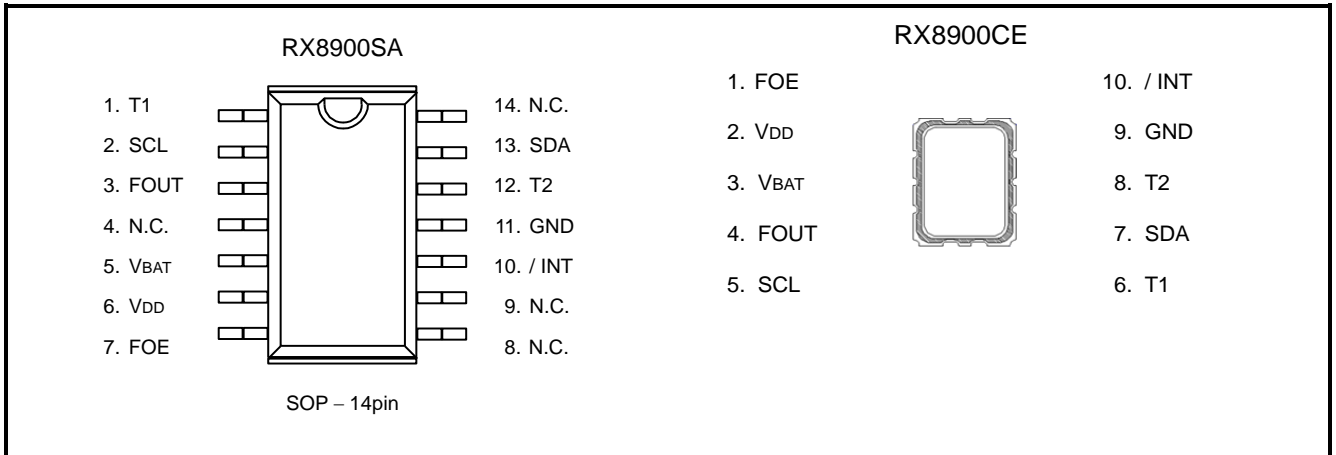

Figure 2 Terminal connections

3.2. Pin Functions

Table 1 Pin Description

Signal name	I/O	Function
SDA	I/O	This pin's signal is used for input and output of address, data, and ACK bits, synchronized with the serial clock used for I ² C communications. Since the SDA pin is an N-ch open drain pin during output, be sure to connect a suitable pull-up resistance relative to the signal line capacity.
SCL	Input	This is the serial clock input pin for I ² C Bus communications.
FOUT	Output	This is the C-MOS output pin with output control provided via the FOE pin. When FOE = "H" (high level), this pin outputs a 32.768 kHz signal. (Depend on FSEL bit) When output is stopped, the FOUT pin = "Hi-Z" (high impedance).
FOE	Input	This is an input pin used to control the output mode of the FOUT pin. When this pin's level is high, the FOUT pin is in output mode. When it is low, output via the FOUT pin is stopped.
/INT	Output	This pin is used to output alarm signals, timer signals, time update signals, and other signals. This pin is an open drain pin.
VBAT	-	This is the power supply pin for backup battery. Connect this pin to a large-capacity capacitor, a secondary battery or similar. When the battery switchover function is not needed, VBAT must be connected to V _{DD} .
VDD	-	This pin is connected to a positive power supply.
GND	-	This pin is connected to a ground.
TEST	Input	Used by the manufacturer for testing. (Do not connect externally.)
T1	Input	Used by the manufacturer for testing. (Do not connect externally.)
T2	-	Used by the manufacturer for testing. (Do not connect externally.)
N.C.	-	This pin is not connected to the internal IC. Leave N.C. pins open or connect them to GND or V _{DD} .

Note: Be sure to connect a bypass capacitor rated at least 0.1 μF between VDD and GND, VBAT and GND.

RX8900 SA / CE

4. Absolute Maximum ratings

Table 2. Absolute Maximum Rating

GND = 0 V

Item	Symbol	Condition	Rating	Unit
Supply voltage (1)	V _{DD}	Between V _{DD} and GND	-0.3 to +6.5	V
Supply voltage (2)	V _{BAT}	Between V _{BAT} and GND	-0.3 to +6.5	V
Input voltage (2)	V _{IN}	FOE, SCL, SDA pins	GND-0.3 to +6.5	V
Output voltage (1)	V _{OUT1}	FOUT pin	GND-0.3 to V _{DD} +0.3	V
Output voltage (2)	V _{OUT2}	SDA and /INT pins	GND-0.3 to +6.5	V
Storage temperature	T _{STG}	When stored separately, without packaging	-55 to +125	°C

5. Recommended Operating Conditions

Table 3. Recommended Operating Conditions

GND = 0 V

Item	Symbol	Condition	Min.	Typ.	Max.	Unit
Operating supply voltage Normal mode (2)	V _{ACCSW}	Between V _{DD} and GND	2.5	3.0	5.5	V
Operating supply voltage In case of single supply (V _{DD} = V _{BAT}) (1)	V _{ACC}	Between V _{DD} and GND (V _{DD} = V _{BAT})	1.6	3.0	5.5	V
Backup power supply voltage	V _{BAT}	Between V _{BAT} and GND	1.6	3.0	5.5	V
Temp. compensation voltage	V _{TEM}	Temperature compensation voltage	2.0	3.0	5.5	V
Clock supply voltage	V _{CLK}	-	1.6	3.0	5.5	V
Operating temperature	T _{OPR}	No condensation	-40	+25	+85	°C

RX8900 SA / CE

5.1. I²C-bus active current

Reference characteristic data (Typical)

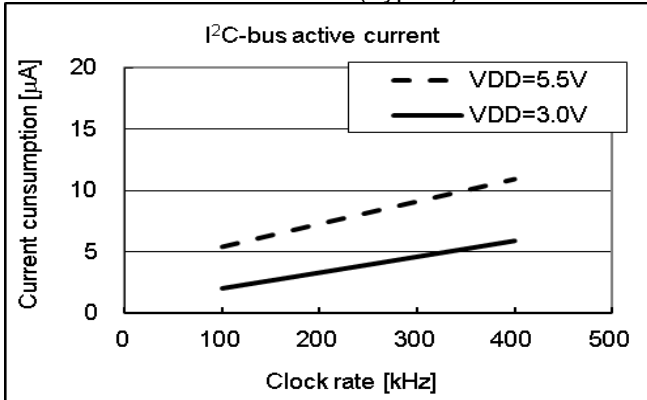

Figure 3 I²C bus current consumption

6. Frequency Characteristics

Table 4. Frequency Characteristics

GND = 0 V

Item	Symbol	Condition	Rating	Unit
Frequency stability	$\Delta f / f$	U A Ta = 0°C to +50°C, VDD = 3.0 V Ta = -40°C to +85°C, VDD = 3.0 V	± 1.9 (*1) ± 3.4 (*2)	$\times 10^{-6}$
		U B Ta = 0°C to +50°C, VDD = 3.0 V Ta = -40°C to +85°C, VDD = 3.0 V	± 3.8 (*3) ± 5.0 (*4)	
		U C Ta = 0°C to +50°C, VDD = 3.0 V Ta = -30°C to +70°C, VDD = 3.0 V	± 3.8 (*3) ± 5.0 (*4)	
Frequency/voltage characteristics	f / V	Ta = +25°C, VDD = 2.0 V to 5.5 V	± 1.0 Max.	$\times 10^{-6} / V$
Oscillation start time	tSTA	Ta = +25°C, VDD = 1.6 V ~ 5.5 V Ta = -40°C to +85°C, VDD = 1.6 V to 5.5 V	1.0 Max. 3.0 Max.	s
Aging	fa	Ta = +25°C, VDD = 3.0 V, first year	± 3 Max.	$\times 10^{-6} /$ year
Temperature Sensor Accuracy	Temp	VDD = 3.0 V	± 5.0 Max.	°C

*1: Equivalent to ± 5 seconds of month deviation. *2: Equivalent to ± 9 seconds of month deviation.

*3: Equivalent to ± 10 seconds of month deviation. *4: Equivalent to ± 13 seconds of month deviation.

RX8900 SA / CE

7. Electrical Characteristics

7.1 DC characteristics

Table 5 DC characteristics *Unless otherwise specified, GND = 0 V, VDD = VBAT = 2.5 V to 5.5 V, Ta = -40 °C to +85 °C

Item	Symbol	Condition	Min.	Typ.	Max.	Unit
Average Current consumption (1)	IDD1	fSCL = 0 Hz, / INT = VDD FOE = GND, VDD = VBAT	VDD = 5 V	0.72	1.50	μA
Average Current consumption (2)	IDD2	FOUT: output OFF (High Z) Compensation interval 2.0 s VDET3 voltage detection time is 2ms	VDD = 3 V	0.70	1.40	
Current consumption (3)	IDD3	fSCL = 0 Hz, / INT = VDD FOE = VDD, VDD = VBAT	VDD = 5 V	1.60	2.50	μA
Current consumption (4)	IDD4	FOUT: 32.768 kHz, CL = 0pF Compensation interval 2.0 s VDET3 voltage detection time is 2ms	VDD = 3 V	1.15	2.40	
Current consumption (5)	IDD5	fSCL = 0 Hz, / INT = VDD FOE = VDD, VDD = VBAT	VDD = 5 V	6.70	8.00	μA
Current consumption (6)	IDD6	FOUT: 32.768 kHz, CL = 30pF Compensation interval 2.0 s VDET3 voltage detection time is 2ms	VDD = 3 V	4.30	5.50	
Current consumption (7)	IDD7	fSCL = 0 Hz, / INT = VDD FOE = GND, VDD = VBAT	VDD = 5 V	0.70	1.45	μA
Current consumption (8)	IDD8	FOUT: output OFF (High Z) Compensation OFF VDET3 voltage detection time is 2ms	VDD = 3 V	0.68	1.35	
Peak Current consumption (9)	IDD9	fSCL = 0 Hz, / INT = VDD FOE = GND, VDD = VBAT	VDD = 5 V	55	100	μA
Peak Current consumption (10)	IDD10	FOUT: output OFF (High Z) Compensation ON Peak current.	VDD = 3 V	50	95	
High-level input voltage	VIH	SCL, SDA, FOE pins	0.8 × VDD		5.5	V
Low-level input voltage	VIL	SCL, SDA, FOE pins	GND - 0.3		0.2 × VDD	V
High-level output voltage	VOH1	FOUT pin	VDD=5 V, IOH=-1 mA	4.5	5.0	V
	VOH2		VDD=3 V, IOH=-1 mA	2.2	3.0	
	VOH3		VDD=3 V, IOH=-100 μA	2.9	3.0	
Low-level output voltage	VOL1	FOUT pin	VDD=5 V, IOL=1 mA	GND	GND+0.5	V
	VOL2		VDD=3 V, IOL=1 mA	GND	GND+0.8	
	VOL3		VDD=3 V, IOL=100 μA	GND	GND+0.1	
	VOL4	/ INT pin	VDD=5 V, IOL=1 mA	GND	GND+0.25	V
	VOL5	/ INT pin	VDD=3 V, IOL=1 mA	GND	GND+0.4	
	VOL6	SDA pin	VDD ≥ 2 V, IOL=3 mA	GND	GND+0.4	V
Input leakage current	ILK	FOE, SCL, SDA pins. VIN = VDD or GND	-0.5		0.5	μA
Output leakage current	IOZ	/ INT, SDA, FOUT pins, VOUT = VDD or GND	-0.5		0.5	μA

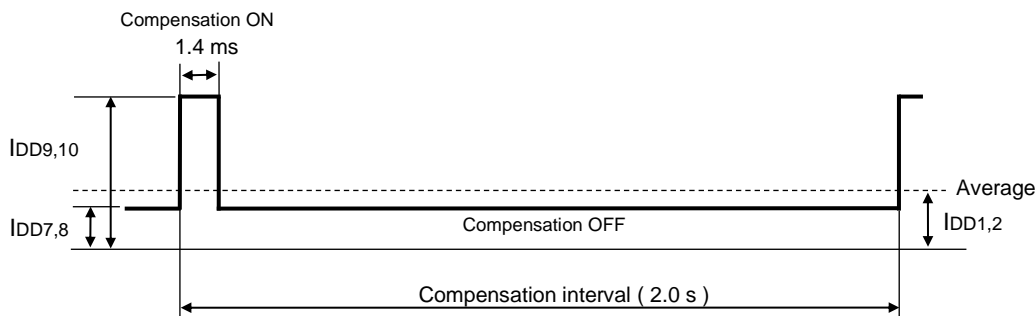

Figure 4 Temperature compensation current consumption

RX8900 SA / CE

7.2. AC Characteristics

* Unless otherwise specified,

Table 6 AC Characteristics

GND = 0 V, VDD = 2.5 V to 5.5 V, Ta = -40 °C to +85 °C

Item	Symbol	Condition	Min.	Typ.	Max.	Unit
SCL clock frequency	fSCL				400	kHz
Start condition setup time	tSU;STA		0.6			μs
Start condition hold time	tHD;STA		0.6			μs
Data setup time	tSU;DAT		100			ns
Data hold time	tHD;DAT		0			ns
Stop condition setup time	tSU;STO		0.6			μs
Bus idle time between start condition and stop condition	tBUF		1.3			μs
Time when SCL = "L"	tLOW		1.3			μs
Time when SCL = "H"	tHIGH		0.6			μs
Rise time for SCL and SDA	tr				0.3	μs
Fall time for SCL and SDA	tph				0.3	μs
Allowable spike time on bus	tSP				50	ns
FOUT duty	tw / t	50% of VDD level	40	50	60	%

Note: These timing specifications are applied in access by 400kHz.

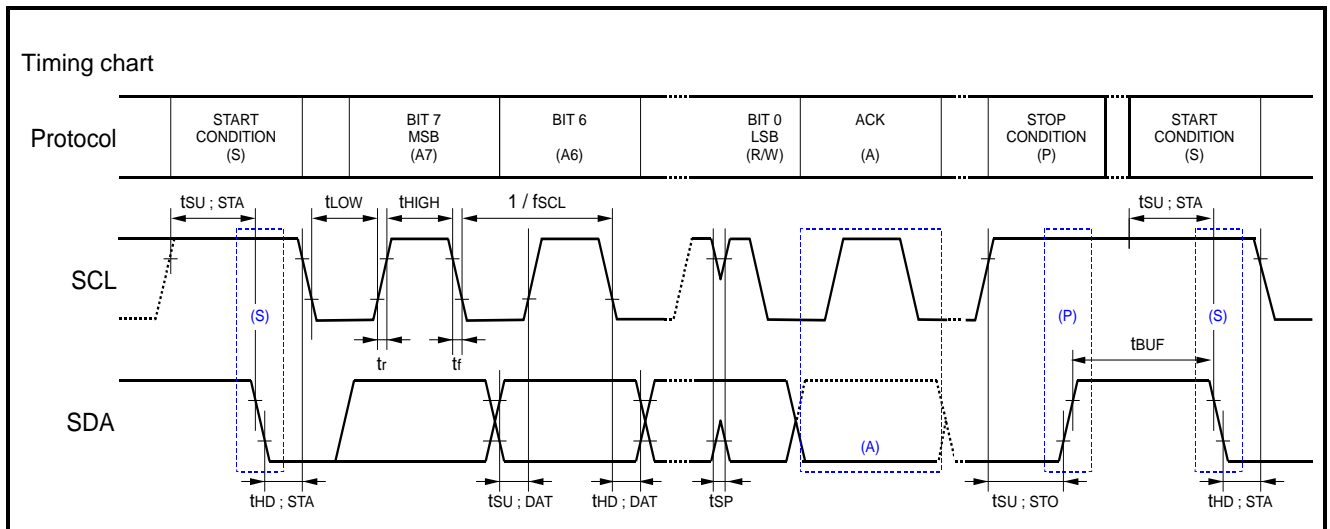

Figure 5 I²C Bus Timing Chart

Warning: When accessing this device, all communication from transmitting the start condition to transmitting the stop condition after access **should be completed within 1 seconds**. If such communication requires **1 seconds** or longer, the I²C bus interface is reset by the internal bus timeout function.

When bus-time-out occur, SDA turns to Hi-Z input mode.

Note: During access to the time registers, the time counting is on hold! This means that up to 1 second can be "lost" in case of unsuccessful communication as mentioned above!

Please make sure to send I²C start condition before actual transmission of the RTCs slave address as otherwise the slave address appears to be shifted by 1 bit!

RX8900 SA / CE

8. Functions

8.1. Description of Registers

8.1.1. Write / Read and Bank Select

Address 00h to 0Fh: Basic time and calendar register ... Compatible with RX8803.

Time and date registers have two addresses from 00h to 06h and 10h to 16h (either can be used with equal results).

Addresses 17h to 18h are Temperature Data, Backup power supply control register.

8.1.2. Register table (Basic time and calendar registers)

Table 7 Basic Time and Calendar Registers

Address	Function	bit 7	bit 6	bit 5	bit 4	bit 3	bit 2	bit 1	bit 0	Read	Write
00 or 10	SEC	○	40	20	10	8	4	2	1	P	P
01 or 11	MIN	○	40	20	10	8	4	2	1	P	P
02 or 12	HOUR	○	○	20	10	8	4	2	1	P	P
03 or 13	WEEK	○	6	5	4	3	2	1	0	P	P
04 or 14	DAY	○	○	20	10	8	4	2	1	P	P
05 or 15	MONTH	○	○	○	10	8	4	2	1	P	P
06 or 16	YEAR	80	40	20	10	8	4	2	1	P	P
07	RAM	•	•	•	•	•	•	•	•	P	P
08	MIN Alarm	AE	40	20	10	8	4	2	1	P	P
09	HOUR Alarm	AE	•	20	10	8	4	2	1	P	P
0A	WEEK Alarm	AE	6	5	4	3	2	1	0	P	P
	DAY Alarm		•	20	10	8	4	2	1		
0B or 1B	Timer Counter 0	128	64	32	16	8	4	2	1	P	P
0C or 1C	Timer Counter 1	•	•	•	•	2048	1024	512	256	P	P
0D or 1D	Extension Register	TEST	WADA	USEL	TE	FSEL1	FSEL0	TSEL1	TSEL0	P	P
0E or 1E	Flag Register	○	○	UF	TF	AF	○	VLF	VDET	P	P
0F or 1F	Control Register	CSEL1	CSEL0	UIE	TIE	AIE	○	○	RESET	P	P

P: Possible, I: Invalid.

RX8900 SA / CE

Note After the initial power-up (from 0 V) or in case the VLF bit returns "1", make sure to initialize all registers, before using the RTC.

Be sure to avoid entering incorrect date and time data, as clock operations are not guaranteed when the data or time data is incorrect.

- During the initial power-up, the following are the default settings for the register values.
Initial value = 0: TEST, WADA, USEL, TE, FSEL1, FSEL0, TSEL0, UF, TF, AF, CSEL1, UIE, TIE, AIE, RESET, VDETOFF, SWOFF, BKSMP1, BKSMP0.
Initial value = 1: TSEL1, VLF, VDET, CSEL0.
At this point, all other register values are undefined, so be sure to perform a reset before using the module.
- Only a "0" can be written to the UF, TF, AF, VLF, or VDET bit.
- Any bit marked with "o" should be used with a value of "0" after initialization.
- Any bit marked with "•" is a RAM bit that can be used to read or write any data.
- The TEST bit is used by the manufacturer for testing. Be sure to set "0" for this bit when writing.
- If an alarm function is not used, registers 08h to 0Ah can be used as RAM. Be clear AIE to "0" in before.
- Reading register value of address 0Bh-0Ch is pre-set data.
If a timer function is not used, register of 0Bh to 0Ch can be used as RAM. Be clear TIE to "0" in before.

8.1.3. Temperature Data, Backup power supply control register

Table 8 Temperature Data, Backup power supply control register

Address	Function	bit 7	bit 6	bit 5	bit 4	bit 3	bit 2	bit 1	bit 0	Read	Write
17	TEMP	128	64	32	16	8	4	2	1	P	I
18	Backup Function	○	○	○	○	VDET OFF	SWOFF	BKSMP1	BKSMP0	P	P
19	Not use	○	○	○	○	○	○	○	○	P	I
1A	Not use	○	○	○	○	○	○	○	○	P	I

P : Possible , I : Invalid

8.1.4. Quick Reference

Table 9 Register Quick Reference

Update interrupt timing		Default
USEL = 0	Once per seconds.	√
USEL = 1	Once per minutes.	
Output Frequency selection		
FSEL1, FSEL0 = 00	32.768 kHz	√
FSEL1, FSEL0 = 01	1024 Hz	
FSEL1, FSEL0 = 10	1 Hz	
FSEL1, FSEL0 = 11	32.768 kHz	
Timer source clock selection.		
TSEL1, TSEL0 = 00	4096 Hz	
TSEL1, TSEL0 = 01	64 Hz	
TSEL1, TSEL0 = 10	Every Seconds update.	√
TSEL1, TSEL0 = 11	Every Minutes update.	
Temperature compensation selection		
CSEL1, CSEL0 = 00	0.5 sec	
CSEL1, CSEL0 = 01	2.0 sec	√
CSEL1, CSEL0 = 10	10 sec	
CSEL1, CSEL0 = 11	30 sec	

RX8900 SA / CE

8.2. Details of Registers

8.2.1. Clock counter SEC - HOUR

Table 10. Clock Counter Registers

Address	Function	bit 7	bit 6	bit 5	bit 4	bit 3	bit 2	bit 1	bit 0
00, 10	SEC	○	40	20	10	8	4	2	1
01, 11	MIN	○	40	20	10	8	4	2	1
02, 12	HOUR	○	○	20	10	8	4	2	1

- Write access to "o" bit are denied. Read value from "o" bit is 0, always.
- The clock counter counts seconds, minutes, and hours.
- The data format is BCD format. For example, when the "seconds" register value is "0101 1001" it indicates 59 seconds.
- * Note with caution that writing non-existent time data may interfere with normal operation of the clock counter.

1) Second counter

Table 11 Second Counter Register

Address	Function	bit 7	bit 6	bit 5	bit 4	bit 3	bit 2	bit 1	bit 0
00, 10	SEC	○	40	20	10	8	4	2	1

- This second counter counts from "00" to "01," "02," and up to 59 seconds, after which it starts again from 00 seconds.

2) Minute counter

Table 12 Minute Counter Register

Address	Function	bit 7	bit 6	bit 5	bit 4	bit 3	bit 2	bit 1	bit 0
01, 11	MIN	○	40	20	10	8	4	2	1

- This minute counter counts from "00" to "01," "02," and up to 59 minutes, after which it starts again from 00 minutes.

3) Hour counter

Table 13 Hour Counter Register

Address	Function	bit 7	bit 6	bit 5	bit 4	bit 3	bit 2	bit 1	bit 0
02, 12	HOUR	○	○	20	10	8	4	2	1

- This hour counter counts from "00" hours to "01," "02," and up to 23 hours, after which it starts again from 00 hours.

RX8900 SA / CE

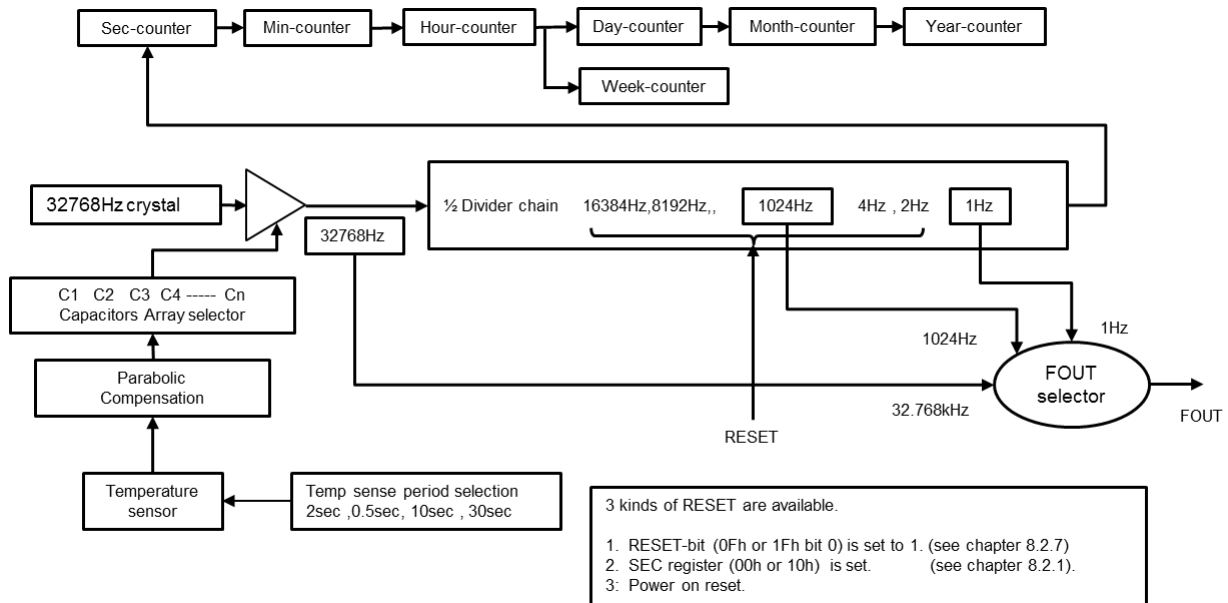

Figure 6 32768Hz Divider, Counter, FOUT
8.2.2. Calendar counter (WEEK - YEAR)

Table 14. Calendar counter Register

Address	Function	bit 7	bit 6	bit 5	bit 4	bit 3	bit 2	bit 1	bit 0
03, 13	WEEK	o	6	5	4	3	2	1	0

- Write access to "o" bit are denied. Read value from "o" bit is 0, always.

1) Day of the WEEK counter

- The day (of the week) is indicated by 7 bits, bit 0 to bit 6.

The day data values are counted as follows: Day 01h → Day 02h → Day 04h → Day 08h → Day 10h → Day 20h → Day 40h → Day 01h → Day 02h, etc.

- The correspondence between days and count values is shown below.

Table 15. Week Counter Register

WEEK	bit 7	bit 6	bit 5	bit 4	bit 3	bit 2	bit 1	bit 0	Day	Data [h]
Write/Read	0	0	0	0	0	0	0	1	Sunday	01 h
	0	0	0	0	0	0	1	0	Monday	02 h
	0	0	0	0	0	1	0	0	Tuesday	04 h
	0	0	0	0	1	0	0	0	Wednesday	08 h
	0	0	0	1	0	0	0	0	Thursday	10 h
	0	0	1	0	0	0	0	0	Friday	20 h
	0	1	0	0	0	0	0	0	Saturday	40 h
Write prohibit	* Do not set "1" to more than one day at the same time. Also, note with caution that any setting other than the seven shown above should not be made as it may interfere with normal operation.								-	-

Table 16. Date Counter Registers

Address	Function	bit 7	bit 6	bit 5	bit 4	bit 3	bit 2	bit 1	bit 0
04, 14	DAY	o	o	20	10	8	4	2	1
05, 15	MONTH	o	o	o	10	8	4	2	1
06, 16	YEAR	80	40	20	10	8	4	2	1

Write access to "o" bit are denied. Read value from "o" bit is 0, always.

- The auto calendar function updates all dates, months, and years 2001 to 28th February 2100 correctly. 2100 is not leap year. But almost RTC-module doesn't skip Feb-29 in 2100.

- The data format is BCD format. For example, a date register value of "0011 0001" indicates the 31st.

Note: with caution that writing non-existent date data may interfere with normal operation of the calendar counter.

RX8900 SA / CE

2) Date counter

Table 17 Day Counter Register

Address	Function	bit 7	bit 6	bit 5	bit 4	bit 3	bit 2	bit 1	bit 0
04, 14	DAY	○	○	20	10	8	4	2	1

- The updating of dates by the date counter varies according to the month setting.
- * A leap year is set whenever the year value is a multiple of four (such as 04, 08, 12, 88, 92, or 96). In February of a leap year, the counter counts dates from "01," "02," "03," to "28," "29," "01," etc.

Table 18. Date update pattern

DAY	Month	Date update pattern
Write/Read	1, 3, 5, 7, 8, 10, or 12	01, 02, 03 ~ 30, 31, 01 ~
	4, 6, 9, or 11	01, 02, 03 ~ 30, 01, 02 ~
	February in normal year	01, 02, 03 ~ 28, 01, 02 ~
	February in leap year	01, 02, 03 ~ 28, 29, 01 ~

3) Month counter

Table 19. Month counter Register

Address	Function	bit 7	bit 6	bit 5	bit 4	bit 3	bit 2	bit 1	bit 0
05, 15	MONTH	○	○	○	10	8	4	2	1

- The month counter counts from 01 (January), 02 (February), and up to 12 (December), then starts again at 01 (January).

4) Year counter

Table 20 Year Counter Register

Address	Function	bit 7	bit 6	bit 5	bit 4	bit 3	bit 2	bit 1	bit 0
06, 16	YEAR	Y80	Y40	Y20	Y10	Y8	Y4	Y2	Y1

- The year counter counts from 00, 01, 02 and up to 99, then starts again at 00.
- Any year that is a multiple of four (04, 08, 12, 88, 92, 96, etc.) is handled as a leap year.

8.2.3. Alarm registers

Table 21 Alarm Registers

Address	Function	bit 7	bit 6	bit 5	bit 4	bit 3	bit 2	bit 1	bit 0
08	MIN Alarm	AE	40	20	10	8	4	2	1
09	HOUR Alarm	AE	•	20	10	8	4	2	1
0A	WEEK Alarm	AE	6	5	4	3	2	1	0
	DAY Alarm		•	20	10	8	4	2	1

- The alarm interrupt function is used, along with the **AEI, AF, and WADA bits**, to set alarms for specified date, day, hour, and minute values.
- When the settings in the above alarm registers and the WADA bit match the current time, the /INT pin goes to low level and "1" is set to the AF bit to report that an alarm interrupt event has occurred.

8.2.4. Fixed-cycle timer control registers

Table 22 Fixed-cycle timer control registers

Address	Function	bit 7	bit 6	bit 5	bit 4	bit 3	bit 2	bit 1	bit 0
0B, 1B	Timer Counter 0	128	64	32	16	8	4	2	1
0C, 1C	Timer Counter 1	•	•	•	•	2048	1024	512	256

- These registers are used to set the preset countdown value for the fixed-cycle timer interrupt function. The **TE, TF, TIE, and TSEL0/1 bits** are also used to set the fixed-cycle timer interrupt function.
- When the value in the above fixed-cycle timer control register changes from 001h to 000h, the /INT pin goes to low level and "1" is set to the TF bit to report that a fixed-cycle timer interrupt event has occurred.

8.2.5. Extension register.

Table 23 Extension Register

Address	Function	bit 7	bit 6	bit 5	bit 4	bit 3	bit 2	bit 1	bit 0
0D, 1D	Extension Register (Default)	TEST (0)	WADA (-)	USEL (-)	TE (-)	FSEL1 (0)	FSEL0 (0)	TSEL1 (-)	TSEL0 (-)

*The default value is the value that is read (or is set internally) after powering up from 0 V

Be sure to always write "0" to TEST bit.

"-" indicates a default value is undefined.

- This register is used to specify the target for the alarm function or time update interrupt function and to select or set operations such as fixed-cycle timer operations.

1) TEST bit

This is the manufacturer's test bit. Its value should always be "0".

Be careful to avoid writing a "1" to this bit when writing to other bits.

Table 24 TEST bit

TEST	Data	Description
Write/Read	0	Normal operation mode * Default
	1	Setting prohibited (manufacturer's test bit)

2) WADA (Week Alarm/Day Alarm) bit

This bit is used to specify either WEEK or DAY as the target of the alarm interrupt function.

Writing a "1" to this bit specifies a DAY alarm, meaning the alarm interrupt is initiated independent of the actual day when the set time is reached.

Writing a "0" to this bit specifies a WEEK alarm, so an alarm interrupt is only generated when the set time is reached on a dedicated day of a week.

3) USEL (Update Interrupt Select) bit

This bit is used to define if the RTC should output a "second update" or "minute update" interrupt, allowing to synchronize external clocks with the time registers of the RTC.

Table 25 USEL bit

USEL	Data	update interrupts	Auto reset time. tRTN
Write/Read	0	second update * Default	500 ms
	1	minute update	Min. 7.813 ms

4) TE (Timer Enable) bit

This bit controls the start/stop setting for the fixed-cycle timer interrupt function.

Writing a "1" to this bit specifies starting of the fixed-cycle timer interrupt function (a countdown starts from a preset value).

Writing a "0" to this bit specifies stopping of the fixed-cycle timer interrupt function.

5) FSEL0,1 (FOUT frequency Select 0, 1) bits

The combination of these two bits is used to set the FOUT frequency.

Note: All frequencies are temperature compensated!

Table 26 FSEL bits

FSEL0,1	FSEL1 (bit 3)	FSEL0 (bit 2)	FOUT frequency
Write/Read	0	0	32768 Hz Output * Default
	0	1	1024 Hz Output
	1	0	1 Hz Output
	1	1	32768 Hz Output

6) TSEL0,1 (Timer Select 0, 1) bits

The combination of these two bits is used to set the countdown period (source clock) for the fixed-cycle timer interrupt function (four settings can be made).

Table 27 TSEL bits

TSEL0,1	TSEL1 (bit 1)	TSEL0 (bit 0)	Source clock
Write/Read	0	0	4096 Hz / Once per 244.14 μ s
	0	1	64 Hz / Once per 15.625 ms
	1	0	"Second" update / Once per second
	1	1	"Minute" update / Once per minute

8.2.6. Flag register

Table 28 Flag Register

Address	Function	bit 7	bit 6	bit 5	bit 4	bit 3	bit 2	bit 1	bit 0
0E, 1E	Flag register (Default)	o (0)	o (0)	UF (-)	TF (-)	AF (-)	o (0)	VLF (1)	VDET (1)

Default is values loaded automatically after power ON from 0V.

Write access to "o" bit are denied. Read value from "o" bit is 0, always.

"-" indicates a default value is undefined.

1) VLF (Voltage Low Flag) bit

VLF indicates the retained reliability of clock functions and internal data.

When VLF was set to "1", it indicates possibility that was lost of both memorized data and clock calendar data. The factor of VLF are 3kinds.

1 Supply voltage drop less than 1.6V(VCLK) was detected.

VLF-voltage-detector is active in anytime. Detection velocity is about 1ms to 10ms.

2 The internal crystal oscillation was stopped. This detector is active in anytime.

Detection velocity is about 100ms.

Once VLF value was set to "1", its "1" is retained until a "0" is written to it.

After initial power ON from 0 V, make sure VLF was set to "1".

3 The Power-On-Reset occur by cold-start occur.

Table 29 VLF bit

VLF	Data	Description
Write	0	The VLF bit is cleared to zero to prepare for the next status detection.
	1	Invalid (writing a 1 will be ignored)!
Read	0	No supply voltage drop occurred, so data are not compromised.
	1	Low voltage has been detected, so data loss might have occurred, and time information might be compromised. All registers must be initialized. This setting is retained until a "zero" is written to this bit.

2) VDET (Voltage Detection Flag) bit

VDET indicates the retained reliability of temperature compensation.

When VET was set to "1", it indicates possibility that was lost of clock stability history.

The factor of VDET.

Supply voltage drop less than 1.95V(VDET) was detected.

VDET is detected in every temperature compensation timing. Detection velocity is about 1ms to 10ms.

Once VDET value is "1", VDET is retained until a "0" is written to it.

After powering up from 0 V, make sure to set this bit's value to "1".

Table 30 VDET bit

VDET	Data	Description
Write	0	The VDET bit is cleared to zero to prepare for the next low voltage detection.
	1	Invalid (writing a 1 will be ignored)!
Read	0	Temperature compensation is normal.
	1	Temperature compensation has been stopped.

3) UF (Update Flag) bit

If set to "0" beforehand, this flag bit's value changes from "0" to "1" when a time update interrupt event has occurred. Once this flag bit's value is "1", its value is retained until a "0" is written to it.

* For details, see "8.4. Time Update Interrupt Function".

4) TF (Timer Flag) bit

If set to "0" beforehand, this flag bit's value changes from "0" to "1" when a fixed-cycle timer interrupt event has occurred. Once this flag bit's value is "1", its value is retained until a "0" is written to it.

* For details, see "8.3. Fixed-cycle Timer Interrupt Function".

5) AF (Alarm Flag) bit

If set to "0" beforehand, this flag bit's value changes from "0" to "1" when an alarm interrupt event has occurred. Once this flag bit's value is "1", its value is retained until a "0" is written to it.

* For details, see "8.5. Alarm Interrupt Function".

8.2.7. Control register

Table 31 Control Register

Address	Function	bit 7	bit 6	bit 5	bit 4	bit 3	bit 2	bit 1	bit 0
0F, 1F	Control Register Default value	CSEL1 0	CSEL0 1	UIE 0	TIE 0	AIE 0	○ 0	○ 0	RESET 0

The default value is the value that is read (or is set internally) after powering up from 0 V.

Write access to "o" bit are denied. Read value from "o" bit is 0, always.

1) CSEL0,1 (Compensation interval Select 0, 1) bits

The combination of these two bits is used to set the temperature compensation interval.

Table 32 CSEL bits

CSEL0,1	CSEL1 Bit 7	CSEL0 Bit 6	Compensation interval
Write/Read	0	0	0.5 s
	0	1	2.0 s Default
	1	0	10 s
	1	1	30 s

RX8900 SA / CE

2) UIE (Update Interrupt Enable) bit

When a time update interrupt event is generated (when the UF bit value changes from "0" to "1"), this bit's value specifies if an interrupt signal is generated (/INT status changes from Hi-Z to low) or is not generated (/INT status remains Hi-Z).

When a "1" is written to this bit, an interrupt signal is generated (/INT status changes from Hi-Z to low) when an interrupt event is generated.

When a "0" is written to this bit, no interrupt signal is generated when an interrupt event occurs.

Table 33 UIE bit

UIE	Data	Function
Write/Read	0	When a time update interrupt event occurs, an interrupt signal is not generated or is canceled (/INT status changes from low to Hi-Z).
	1	When a time update interrupt event occurs, an interrupt signal is generated (/INT status changes from Hi-Z to low). * When a time update interrupt event occurs, low-level output from the /INT pin occurs only when the value of the control register's UIE bit is "1". This /INT status is automatically cleared (/INT status changes from low to Hi-Z) earliest 7.813 ms after the interrupt occurs.

3) TIE (Timer Interrupt Enable) bit

When a fixed-cycle timer interrupt event occurs (when the TF bit value changes from "0" to "1"), this bit's value specifies if an interrupt signal is generated (/INT status changes from Hi-Z to low) or is not generated (/INT status remains Hi-Z). When a "1" is written to this bit, an interrupt signal is generated (/INT status changes from Hi-Z to low) when an interrupt event is generated.

When a "0" is written to this bit, no interrupt signal is generated when an interrupt event occurs.

Table 34 TIE bit

TIE	Data	Function
Write/Read	0	When a fixed-cycle timer interrupt event occurs, an interrupt signal is not generated or is canceled (/INT status changes from low to Hi-Z).
	1	When a fixed-cycle timer interrupt event occurs, an interrupt signal is generated (/INT status changes from Hi-Z to low). * When a fixed-cycle timer interrupt event has been generated low-level output from the /INT pin occurs only when the value of the control register's TIE bit is "1". Earliest 7.813 ms after the interrupt occurs, the /INT status is automatically cleared (/INT status changes from low to Hi-Z).

4) AIE (Alarm Interrupt Enable) bit

When an alarm timer interrupt event occurs (when the AF bit value changes from "0" to "1"), this bit's value specifies if an interrupt signal is generated (/INT status changes from Hi-Z to low) or is not generated (/INT status remains Hi-Z).

When a "1" is written to this bit, an interrupt signal is generated (/INT status changes from Hi-Z to low) when an interrupt event is generated.

When a "0" is written to this bit, no interrupt signal is generated when an interrupt event occurs.

Table 35 AIE bit

AIE	Data	Function
Write/Read	0	When an alarm interrupt event occurs, an interrupt signal is not generated or is canceled (/INT status changes from low to Hi-Z).
	1	When an alarm interrupt event occurs, an interrupt signal is generated (/INT status changes from Hi-Z to low). * When an alarm interrupt event has been generated low-level output from the /INT pin occurs only when the value of the control register's AIE bit is "1". This setting is retained until the AF bit value is cleared to zero. (No automatic cancellation)

* For details, see "8.5. Alarm Interrupt Function".

[Note]

- (1) The /INT pin is a shared interrupt output pin for three types of interrupts. It outputs the "OR" result of these interrupt outputs. When an interrupt has occurred (when the /INT pin is at low level), the UF, TF, read AF flags to determine which flag has a value of "1" (this indicates which type of interrupt event has occurred).
- (2) The status of update interrupt, timer interrupt and alarm interrupt can be checked by software polling without using the /INT pin. In this case, write "0" into UIE, TIE, and AIE bits to avoid physical interrupt generation and thus reduce power consumption.

RX8900 SA / CE

5) RESET bit

RESET bit was prepared for the synchronized starting of time or timer.
The detailed function of reset.

For example.

S is start condition. P is stop condition. RS is re-start condition.

S---Slave address(w)---ACK1---0Fh---ACK2---01h---ACK3---RS---R/W access---P.

RESET-bit is set at ACK3, but RESET doesn't execute.

after set of RESET, RESET-function executes momentarily at next P, and RESET-bit clears automatically.

RESET area of circuit is the count-down-chain of 2Hz from 16kHz, are cleared.

Therefore, RESET do not affect 32kHz output.

Next update timing of a Seconds counter from RESET.

That range is 1000ms-30.5μs from just 1000ms.

RESET affects to time update interruption, alarm, and timer.

Note:

RESET is not released by the reception of a RE-START condition before receiving a STOP condition.

Unnecessary use of RESET will be the cause of delay error of Calendar and Clock.

8.2.8. Temperature Data register

Table 36 Temperature Data Register

Address	Function	bit 7	bit 6	bit 5	bit 4	bit 3	bit 2	bit 1	bit 0
17	TEMP	128	64	32	16	8	4	2	1

1) Temperature Data register

This register can be used to read digital temperature data.

The temperature data are updated during operation of the temperature compensation circuit.

You can make a conversion to a centigrade by temperature data by calculating in the following expression.

$$\text{Temperature}[^{\circ}\text{C}] = (\text{TEMP}[7:0] * 2 - 187.19) / 3.218$$

8.2.9. Backup power supply control register

Table 37 Backup power supply control register

Address	Function	bit 7	bit 6	bit 5	bit 4	bit 3	bit 2	bit 1	bit 0
18	Backup Function	○	○	○	○	VDET OFF	Swoff	BKSMP1	BKSMP0

This register controls the functionality of the power switchover and backup function.

1) VDETOFF bit (Voltage Detector OFF)

This bit controls the voltage detection circuit of the main power supply V_{DD} .

For details, see "8.8.5. Related registers of the backup power supply switchover function"

2) SWOFF bit (Switch OFF)

This bit controls the internal P-MOS switch for preventing back flow.

For details, see "8.8.5. Related registers of the backup power supply switchover function".

3) BKSMP1, BKSMP0 bit (Backup mode Sampling time)

These bits control the operation time when to be intermittently driven the V_{DD} voltage detection.

For details, see "8.8.5. Related registers of the backup power supply switchover function"

8.3. Fixed Cycle Timer Interrupt Function

This interruption is released automatically, that is most suitable for a wakeup timer or an interval operation system. The fixed-cycle timer interrupt generation function generates an interrupt event periodically at any fixed cycle set between 244.14 μ s and 4095 minutes.

When an interrupt event is generated, the /INT pin goes to low level and "1" is set to the TF bit to report that an event has occurred. (However, when a fixed-cycle timer interrupt event has been generated low-level output from the /INT pin occurs only when the value of the control register's TIE bit is "1". Earliest 7.813 ms after the interrupt occurs, the /INT status is automatically cleared (/INT status changes from low-level to Hi-Z).

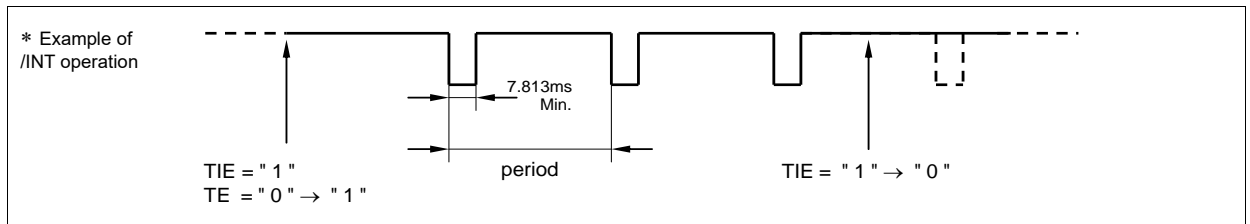

Figure 7 Wakeup Timer Interrupt.

8.3.1. Diagram of fixed-cycle timer interrupt function

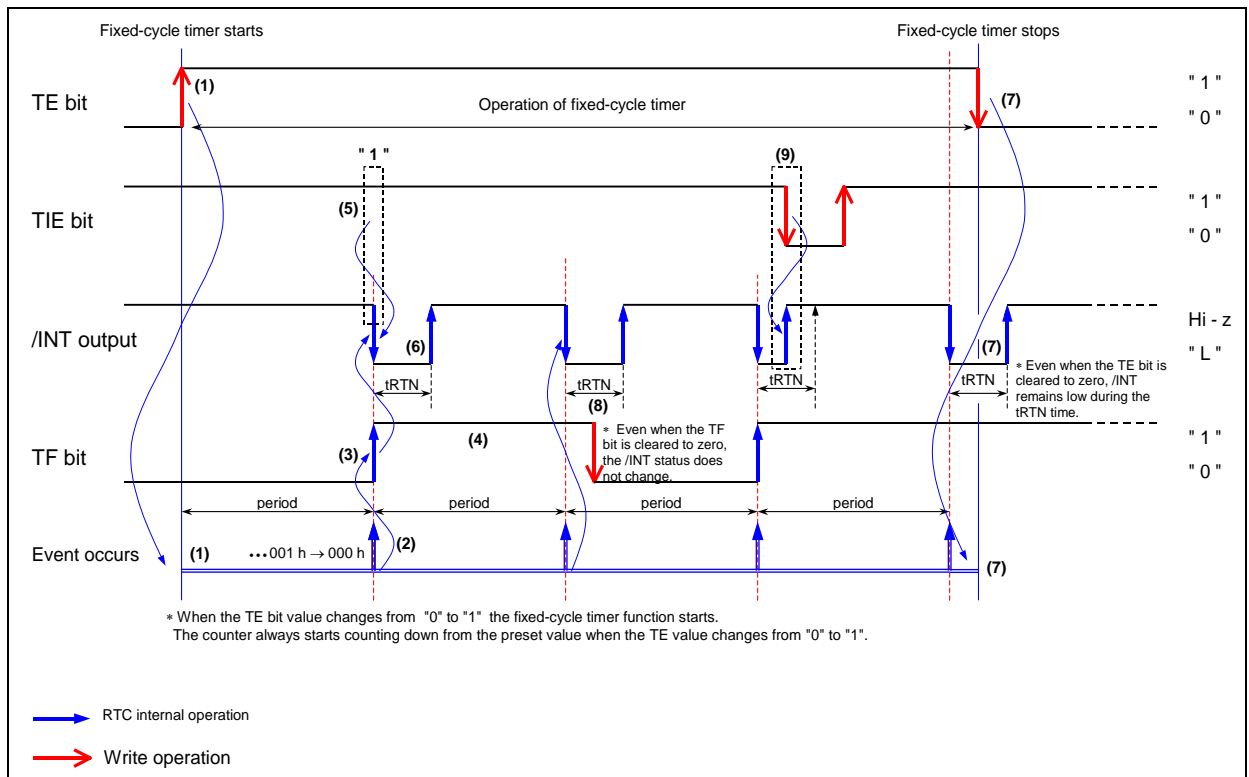

Figure 8 Fixed-cycle Timer Interrupt Timing Chart.

- (1) When a "1" is written to the TE bit, the fixed-cycle timer countdown starts from the preset value.
- (2) A fixed-cycle timer interrupt event starts a countdown based on the countdown period (source clock). When the count value changes from 001h to 000h, an interrupt event occurs.
* After the interrupt event occurs, the counter automatically reloads the preset value and again starts to count down. (Repeated operation)
- (3) When a fixed-cycle timer interrupt event occurs, "1" is written to the TF bit.
- (4) When the TF bit = "1" its value is retained until it is cleared to zero.
- (5) If the TIE bit = "1" when a fixed-cycle timer interrupt occurs, /INT pin output goes low.
* If the TIE bit = "0" when a fixed-cycle timer interrupt occurs, /INT pin output remains Hi-Z.
- (6) Output from the /INT pin remains low during the tRTN period following each event, after which it is automatically cleared to Hi-Z status.
* /INT is again set low when the next interrupt event occurs.
- (7) When a "0" is written to the TE bit, the fixed-cycle timer function is stopped, and the /INT pin is set to Hi-Z status.
* When /INT = low, the fixed-cycle timer function is stopped. The tRTN period is the maximum amount of time before the /INT pin status changes from low to Hi-Z.
- (8) As long as /INT = low, the /INT pin status does not change when the TF bit value changes from "1" to "0".
- (9) When /INT = low, the /INT pin status changes from low to Hi-Z as soon as the TIE bit value changes from "1" to "0".

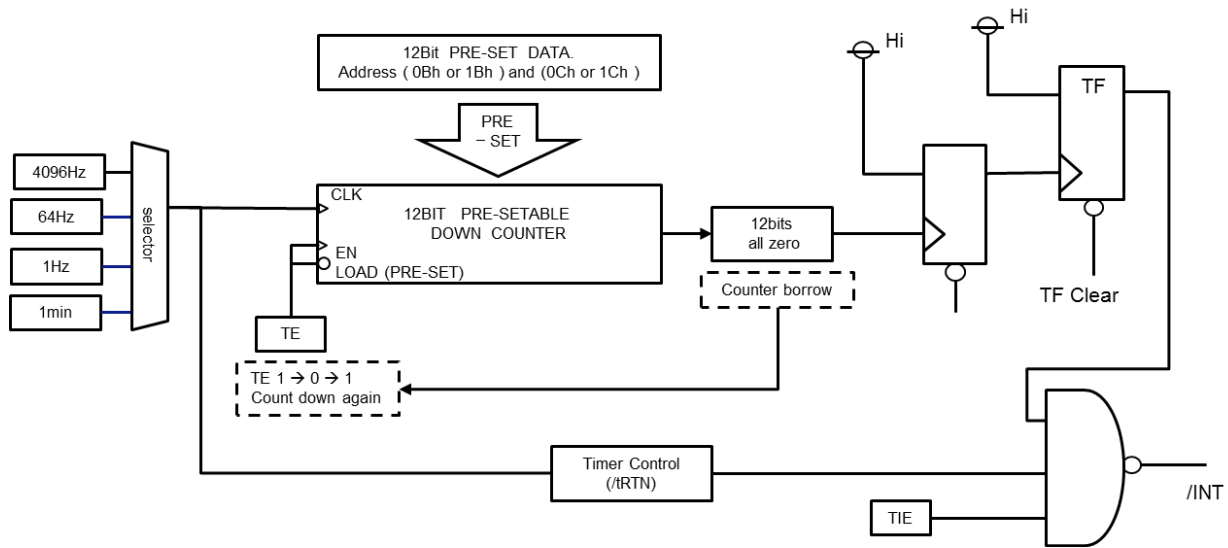

Figure 9 Fixed-cycle Timer Interrupt Block Diagram

8.3.2. Related registers for function of time update interrupts.

Table 38 Related registers for function of time update interrupts.

Address	Function	bit 7	bit 6	bit 5	bit 4	bit 3	bit 2	bit 1	bit 0
0B, 1B	Timer Counter 0	128	64	32	16	8	4	2	1
0C, 1C	Timer Counter 1	•	•	•	•	2048	1024	512	256
0D, 1D	Extension Register	TEST	WADA	USEL	TE	FSEL1	FSEL0	TSEL1	TSEL0
0E, 1E	Flag Register	◦	◦	UF	TF	AF	EVF	VLF	VDET
0F, 1F	Control Register	CSEL1	CSEL0	UIE	TIE	AIE	EIE	◦	RESET

Write access to "o" bit are denied. Read value from "o" bit is 0, always.

Bits marked with "•" are RAM bits that can contain any value and are read/write-accessible.

Before entering settings for operations, we recommend writing a "0" to the TE and TIE bits to prevent hardware interrupts from occurring inadvertently while entering settings.

When the RESET bit value is "1" the time update interrupt function does not operate.

When the fixed-cycle timer interrupt function is not being used, the fixed-cycle timer control register (0Bh to 0Ch) can be used as a RAM register. In such cases, stop the fixed-cycle timer function by writing "0" to the TE and TIE bits.

1) TSEL0,1 bits (Timer Select 0, 1)

The combination of these two bits is used to set the countdown period (source clock) for the fixed-cycle timer interrupt function (four settings can be made).

Table 39 TSEL bits

TSEL0,1	TSEL1 Bit 1	TSEL0 Bit 0	Source clock	Auto reset time tRTN (Min.)	Effects of RESET bits
Write/Read	0	0	4096 Hz /Once per 244.14 μs	122 μs	–
	0	1	64 Hz / Once per 15.625 ms	7.813 ms	* Does not operate when the RESET bit value is "1".
	1	0	"Second" update /Once per second	7.813 ms	
	1	1	"Minute" update /Once per minute	7.813 ms	

*1) The /INT pin's auto reset time (tRTN) varies as shown above according to the source clock setting.

*2) When the source clock has been set to "second update" or "minute update", the timing of both countdown and interrupts is coordinated with the clock update timing.

2) Fixed-cycle Timer Control register (Reg - 0Bh to 0Ch)

This register is used to set the default (preset) value for the counter. Any count value from 1 (001 h) to 4095 (FFFh) can be set. The counter counts down based on the source clock's period, and when the count value changes from 001h to 000h, the TF bit value becomes "1".

The countdown that starts when the TE bit value changes from "0" to "1" always begins from the set value.

Be sure to write "0" to the TE bit before writing a value into the timer counter register. If a value is written while TE = "1" the first subsequent event will not be generated correctly.

Table 40 Timer Counter Registers

Address 0C,1C Timer Counter 1								Address 0B,1B Timer Counter 0							
bit 7	bit 6	bit 5	bit 4	bit 3	bit 2	bit 1	bit 0	bit 7	bit 6	bit 5	bit 4	bit 3	bit 2	bit 1	bit 0
•	•	•	•	2048	1024	512	256	128	64	32	16	8	4	2	1

3) TE (Timer Enable) bit

This bit controls the start/stop setting for the fixed-cycle timer interrupt function.

Table 41 TE bit

TE	Data	Description
Write/Read	0	Stops fixed-cycle timer interrupt function.
	1	Starts fixed-cycle timer interrupt function. * The countdown that starts when the TE bit value changes from "0" to "1" always begins from the preset value.

4) TF (Timer Flag) bit

If set to "0" beforehand, this flag bit's value changes from "0" to "1" when a fixed-cycle timer interrupt event has occurred. Once this flag bit's value is "1", its value is retained until a "0" is written to it.

Table 42 TF bit

TF	Data	Description
Write	0	The TF bit is cleared to zero to prepare for the next status detection. When the TF bit is cleared to zero in tRTN, the /INT status does not release from active Low to end of tRTN.
	1	Invalid (writing a 1 will be ignored)!
Read	0	Fixed-cycle timer interrupt events are not detected.
	1	Fixed-cycle timer interrupt events are detected. (Result is retained until this bit is cleared to zero.)

5) TIE (Timer Interrupt Enable) bit

When a fixed-cycle timer interrupt event occurs (when the TF bit value changes from "0" to "1"), this bit's value specifies whether an interrupt signal is generated (/INT status changes from Hi-Z to low) or is not generated (/INT status remains Hi-Z).

Table 43 TIE bit

TIE	Data	Description
Write/Read	0	1) When a fixed-cycle timer interrupt event occurs, an interrupt signal is not generated or is canceled (/INT status remains Hi-Z). 2) When a fixed-cycle timer interrupt event occurs, the interrupt signal is canceled (/INT status changes from low to Hi-Z). * Even when the TIE bit value is "0" another interrupt event may change the /INT status to low (or may hold /INT = "L").
	1	When a fixed-cycle timer interrupt event occurs, an interrupt signal is generated (/INT status changes from Hi-Z to low). * When a fixed-cycle timer interrupt event has been generated low-level output from the /INT pin occurs only when the value of the control register's TIE bit is "1". Earliest 7.813 ms the interrupt occurs, the /INT status is automatically cleared (/INT status changes from low to Hi-Z).

8.3.3. Fixed-cycle timer interrupt interval (example)

Table 44 Fixed-cycle timer interrupt interval

Timer Counter setting	Source clock			
	4096 Hz TSEL1,0 = 0,0	64 Hz TSEL1,0 = 0,1	"Second" update TSEL1,0 = 1,0	"Minute" update TSEL1,0 = 1,1
0	–	–	–	–
1	244.14 μ s	15.625 ms	1 s	1 min
2	488.28 μ s	31.25 ms	2 s	2 min
⋮	⋮	⋮	⋮	⋮
41	10.010 ms	640.63 ms	41 s	41 min
205	50.049 ms	3.203 s	205 s	205 min
410	100.10 ms	6.406 s	410 s	410 min
2048	500.00 ms	32.000 s	2048 s	2048 min
⋮	⋮	⋮	⋮	⋮
4095	0.9998 s	63.984 s	4095 s	4095 min

- Time error in fixed-cycle timer
A time error in the fixed-cycle timer will produce a positive or negative time period error in the selected source clock.

8.3.4. Fixed-cycle timer start timing.

Counting down of the fixed-cycle timer value starts at the rising edge of the SCL signal that occurs when the TE value is changed from "0" to "1" (after bit 0 is transferred).

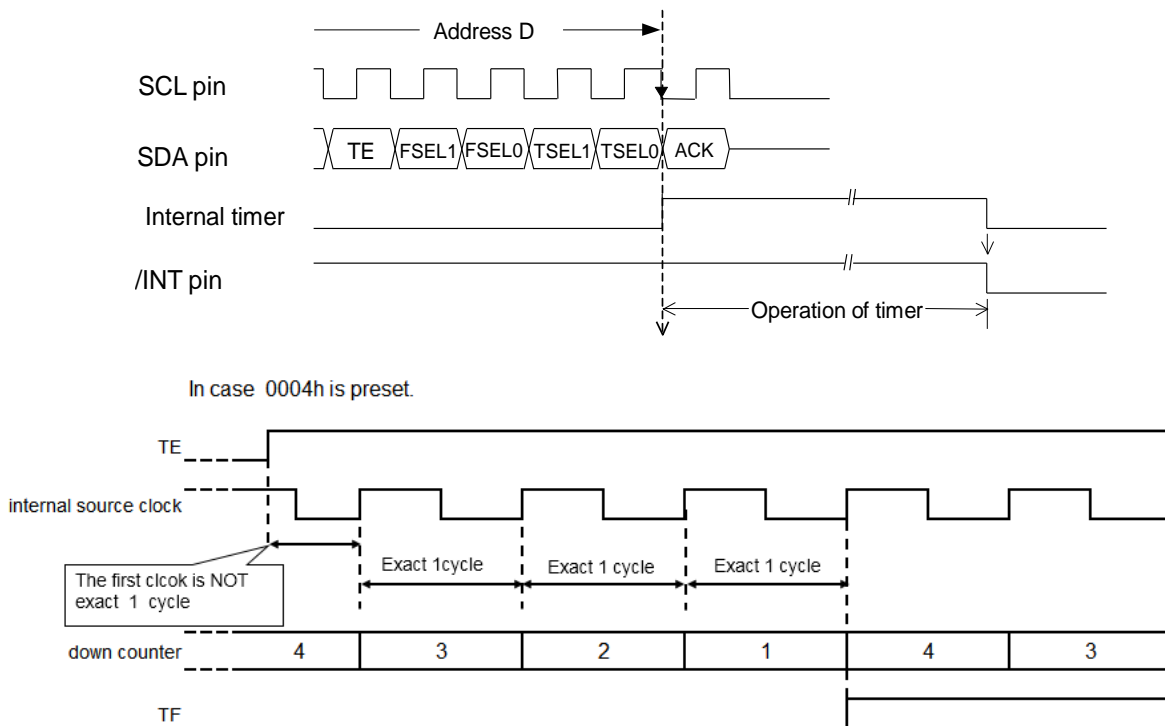

Figure 8-6. Source clock and fixed-cycle timer

Figure 11 An error of first count down.

8.4. Time Update Interrupt Function

The time update interrupt function generates interrupt events at one-second or one-minute intervals, according to the timing of the internal clock.

When an interrupt event occurs, the UF bit value becomes "1" and the /INT pin goes to low level to indicate that an event has occurred. (However, when a fixed-cycle timer interrupt event has been generated, low-level output from the /INT pin occurs only when the value of the control register's UIE bit is "1". This /INT status is automatically cleared (/INT status changes from low level to Hi-Z) earliest 7.813 ms (fixed value) after the interrupt occurs.

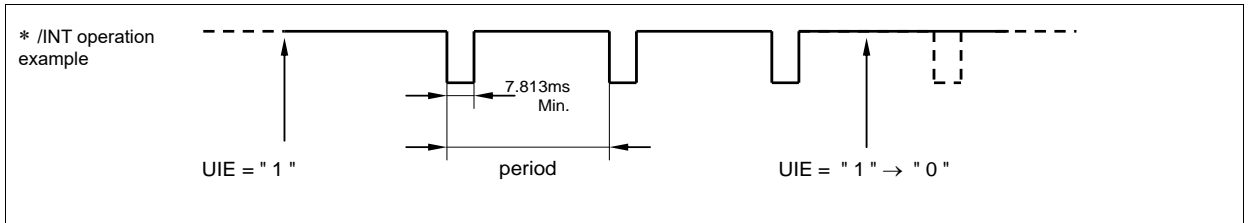

Figure 12 Time Update Interrupt

8.4.1. Time update interrupt function diagram

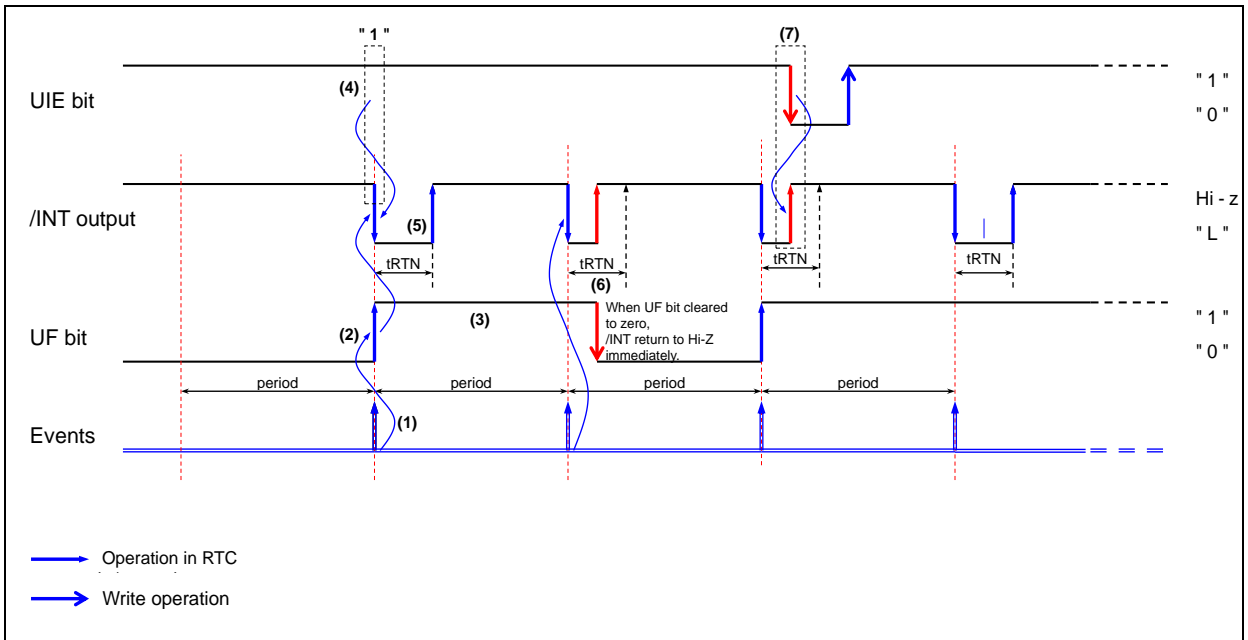

Figure 13 Time Update Interrupt Timing Chart.

- (1) A time update interrupt event occurs when the internal clock's value matches either the second update time or the minute update time. The USEL bit's specification determines whether it is the second update time or the minute update time that must be matched.
- (2) When a time update interrupt event occurs, the UF bit value becomes "1".
- (3) When the UF bit value is "1" its value is retained until it is cleared to zero.
- (4) When a time update interrupt occurs, /INT pin output is low if UIE = "1".
* If UIE = "0" when a timer update interrupt occurs, the /INT pin status remains Hi-Z.
- (5) Each time an event occurs, /INT pin output is low only up to the tRTN time (which is fixed as 7.813 ms for time update interrupts) after which it is automatically cleared to Hi-Z.
* /INT pin output goes low again when the next interrupt event occurs.
- (6) When UF bit cleared to zero, /INT return to Hi-Z immediately.
- (7) When /INT = low, the /INT pin status changes from low to Hi-Z as soon as the UIE bit value changes from "1" to "0".

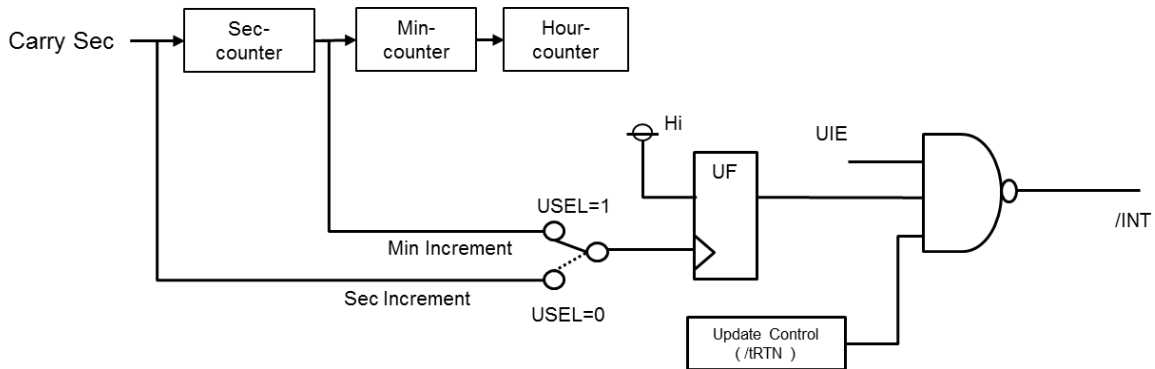

Figure 14 Time Update Interrupt Block Diagram

8.4.2. Related registers for time update interrupt functions.

Table 45 Related registers for time update interrupt functions.

Address	Function	bit 7	bit 6	bit 5	bit 4	bit 3	bit 2	bit 1	bit 0
0D, 1D	Extension Register	TEST	WADA	USEL	TE	FSEL1	FSEL0	TSEL1	TSEL0
0E, 1E	Flag Register	○	○	UF	TF	AF	○	VLF	VDET
0F, 1F	Control Register	CSEL1	CSEL0	UIE	TIE	AIE	○	○	RESET

Write access to "o" bit are denied. Read value from "o" bit is 0, always.

Before entering settings for operations, we recommend writing a "0" to the UIE bit to prevent hardware interrupts from occurring inadvertently while entering settings.

When the RESET bit value is "1" time update interrupt events do not occur.

Although the time update interrupt function cannot be fully stopped, if "0" is written to the UIE bit, the time update interrupt function can be prevented from changing the /INT pin status to low.

1) USEL (Update Interrupt Select) bit

This bit is used to select "second" update or "minute" update as the timing for generation of time update interrupt events.

Table 46 USEL bit.

USEL	Data	Description
Write/Read	0	Selects "second update" (once per second) as the timing for generation of interrupt events
	1	Selects "minute update" (once per minute) as the timing for generation of interrupt events

2) UF (Update Flag) bit

Once it has been set to "0", this flag bit value changes from "0" to "1" when a time update interrupt event occurs. When this flag bit = "1" its value is retained until a "0" is written to it.

Table 47 UF bit

UF	Data	Description
Write	0	The UF bit is cleared to zero to prepare for the next status detection. when UF bit cleared to zero, /INT return to Hi-Z immediately.
	1	Invalid (writing a 1 will be ignored)!
Read	0	Time update interrupt events are not detected.
	1	Time update interrupt events are detected. (The result is retained until this bit is cleared to zero.)

3) UIE (Update Interrupt Enable) bit

When a time update interrupt event occurs (UF bit value changes from "0" to "1"), this bit selects whether to outputs a Low interrupt signal or to not outputs it.

Table 48 UIE bit

UIE	Data	Description
Write/Read	0	1) Does not generate an interrupt signal when a time update interrupt event occurs (/INT remains Hi-Z) 2) Cancels interrupt signal triggered by time update interrupt event (/INT changes from low to Hi-Z). * Even when the UIE bit value is "0" another interrupt event may change the /INT status to low (or may hold /INT = "L").
	1	When a time update interrupt event occurs, an interrupt signal is generated (/INT status changes from Hi-Z to low). * When a time update interrupt event occurs, low-level output from the /INT pin occurs only when the UIE bit value is "1". Earliest 7.813 ms after the interrupt occurs, the /INT status is automatically cleared (/INT status changes from low to Hi-Z).

8.5. Alarm Interrupt Function

The alarm interrupt generation function generates interrupt events for alarm settings such as date, day, hour, and minute settings. When an interrupt event occurs, the AF bit value is set to "1" and the /INT pin goes to low level to indicate that an event has occurred.

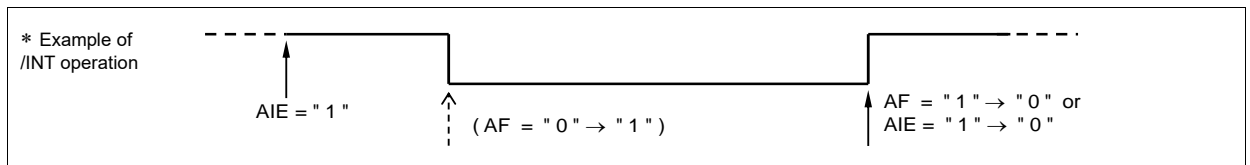

Figure 15 Alarm Interrupt

8.5.1. Diagram of alarm interrupt function

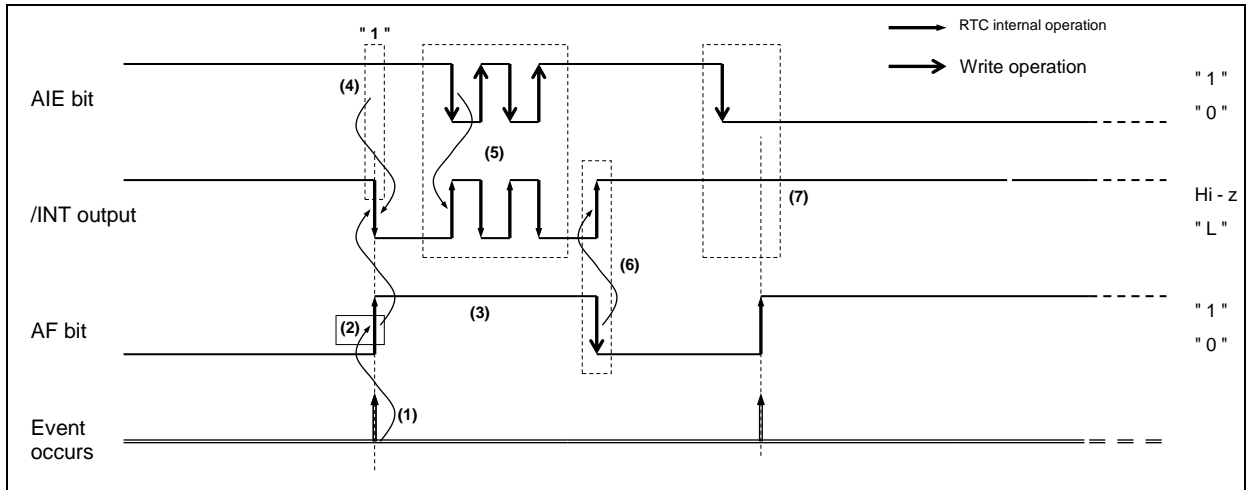

Figure 16 Alarm Interrupt Timing Chart.

- (1) The minute, hour, day and date, when an alarm interrupt event is supposed to occur has to be set in advance, along with the WADA bit (Note) Even if the current date/time is used as the setting, the alarm will not occur until the counter counts up to the current date/time (i.e., an alarm will occur next time, not immediately).
- (2) When a time update interrupt event occurs, the AF bit values set to "1".
- (3) When the AF bit = "1", its value is retained until it is cleared to zero.
- (4) If AIE = "1" when an alarm interrupt occurs, the /INT pin output goes low.
When an alarm interrupt event occurs, /INT pin output goes low, and this status is then held until it is cleared via the AF bit or AIE bit.
- (5) If the AIE value is changed from "1" to "0" while /INT is low, the /INT status immediately changes from low to Hi-Z. After the alarm interrupt occurs and before the AF bit value is cleared to zero, the /INT status can be controlled via the AIE bit.
- (6) If the AF bit value is changed from "1" to "0" while /INT is low, the /INT status immediately changes from low to Hi-Z.
- (7) If the AIE bit value is "0" when an alarm interrupt occurs, the /INT pin status remains Hi-Z.

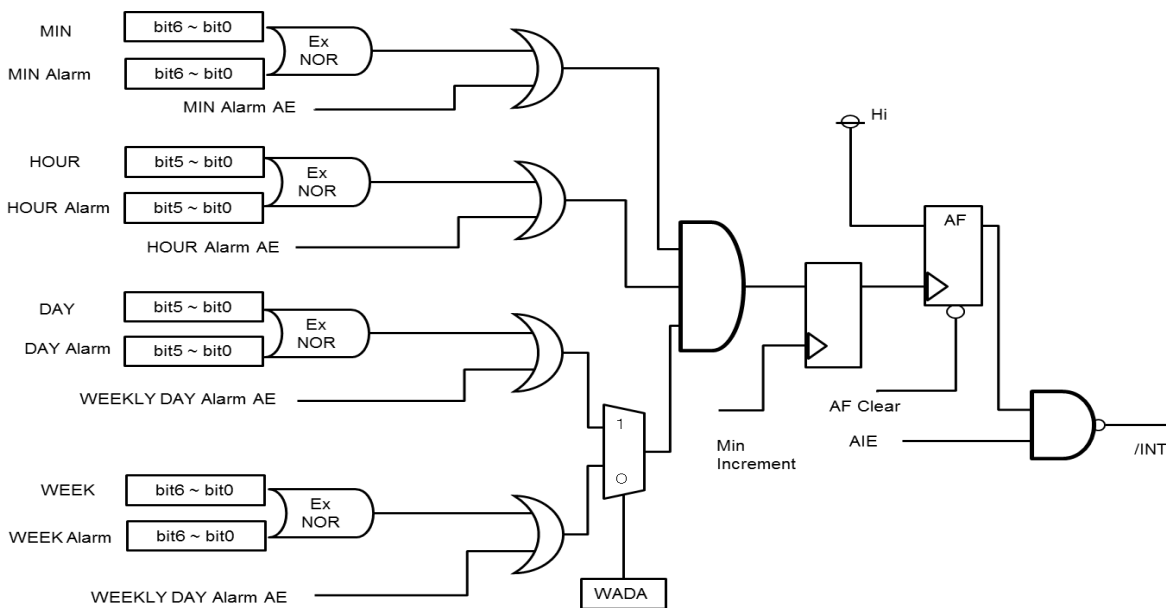

Figure 17 Alarm Interrupt Block Diagram

8.5.2. Related registers

Table 49 Alarm Related Registers

Address	Function	bit 7	bit 6	bit 5	bit 4	bit 3	bit 2	bit 1	bit 0
01, 11	MIN	o	40	20	10	8	4	2	1
02, 12	HOUR	o	o	20	10	8	4	2	1
03, 13	WEEK	o	6	5	4	3	2	1	0
04, 14	DAY	o	o	20	10	8	4	2	1
08	MIN Alarm	AE	40	20	10	8	4	2	1
09	HOUR Alarm	AE	•	20	10	8	4	2	1
0A	WEEK Alarm	AE	6	5	4	3	2	1	0
	DAY Alarm		•	20	10	8	4	2	1
0D, 1D	Extension Register	TEST	WADA	USEL	TE	FSEL1	FSEL0	TSEL1	TSEL0
0E, 1E	Flag Register	o	o	UF	TF	AF	o	VLF	VDET
0F, 1F	Control Register	CSEL1	CSEL0	UIE	TIE	AIE	o	o	RESET

Write access to "o" bit are denied. Read value from "o" bit is 0, always.

Bits marked with "•" are RAM bits that can contain any value and are read/write-accessible.

Before entering settings for operations, we recommend writing a "0" to the AIE bit to prevent hardware interrupts from occurring inadvertently while entering settings.

When the alarm interrupt function is not being used, the Alarm registers (Reg – 08h to 0Ah) can be used as a RAM register. In such cases, be sure to write "0" to the AIE bit.

When the AIE bit value is "1" and the Alarm registers (Reg – 08h to 0Ah) is being used as a RAM register, /INT may be assert to low level unintentionally.

RX8900 SA / CE

1) WADA (Week Alarm /Day Alarm) bit

The alarm interrupt function uses either "Day" or "Week" as its target. The WADA bit is used to specify either WEEK or DAY as the target for alarm interrupt events.

Table 50 WADA bit

WADA	Data	Description
Write/Read	0	Sets WEEK as target of alarm function (DAY setting is ignored)
	1	Sets DAY as target of alarm function (WEEK setting is ignored)

2) Alarm registers

Table 51 Alarm Registers

Address	Function	bit 7	bit 6	bit 5	bit 4	bit 3	bit 2	bit 1	bit 0
08	MIN Alarm	AE	40	20	10	8	4	2	1
09	HOUR Alarm	AE	•	20	10	8	4	2	1
0A	WEEK Alarm	AE	6	5	4	3	2	1	0
	DAY Alarm		•	20	10	8	4	2	1

The minute, hour, day and date when an alarm interrupt event will occur is set using this register and the WADA bit.

In the WEEK alarm /Day alarm register (Reg - 0Ah), the setting selected via the WADA bit determines whether WEEK alarm data or DAY alarm data will be set. If WEEK has been selected via the WADA bit, multiple days can be set (such as Monday, Wednesday, Friday, Saturday).

When the settings made in the alarm registers and the WADA bit match the current time, the AF bit value is changed to "1". At that time, if the AIE bit value has already been set to "1", the /INT pin goes low.

Note: AE-bit is low active, so in order to enable 1 interrupt every hour once the actual minutes match the alarm setting, it is necessary to set the AE of register 08h to 0 and the AE of 09h and 0Ah to 1.

In order to generate an alarm interrupt only once a week, all 3 AE-bits have to be set "0".

- The alarm function is not a HW feature but software function inside the RTC!
- In case "AE" bit of register 0Ah is set to "1", the day will be ignored, and an interrupt occurs once the actual time matches the minutes and/or hour setting of the alarm register.

(Example) Write 80h (AE = "1") to the WEEK Alarm /DAY Alarm register (Reg - 0Ah):

Only the hour and minute settings are used as alarm comparison targets. The week and date settings are not used as alarm comparison targets.

As a result, alarm occurs if only the hour and minute values match the alarm data.

- If all three AE bit values are "1" the week/date and time settings are ignored, and an alarm interrupt event will occur once per minute.

3) AF (Alarm Flag) bit

When this flag bit value is already set to "0", occurrence of an alarm interrupt event changes it to "1". When this flag bit value is "1", its value is retained until a "0" is written to it.

Table 52 AF bit

AF	Data	Description
Write	0	The AF bit is cleared to zero to prepare for the next status detection. * When the AF bit is cleared to zero, the /INT release to Hi-Z from active Low of Alarm event.
	1	Invalid (writing a 1 will be ignored)!
Read	0	Alarm interrupt events are not detected.
	1	Alarm interrupt events are detected. (Result is retained until this bit is cleared to zero.)

4) AIE (Alarm Interrupt Enable) bit

When an alarm interrupt event occurs (when the AF bit value changes from "0" to "1"), this bit's value specifies whether an interrupt signal is generated (/INT status changes from Hi-Z to low) or is not generated (/INT status remains Hi-Z).

RX8900 SA / CE

Table 53 AIE bit

AIE	Data	Description
Write/Read	0	1) When an alarm interrupt event occurs, an interrupt signal is not generated or is canceled (/INT status remains Hi-Z). 2) When an alarm interrupt event occurs, the interrupt signal is canceled (/INT status changes from low to Hi-Z). * Even when the AIE bit value is "0" another interrupt event may change the /INT status to low (or may hold /INT = "L").
	1	When an alarm interrupt event occurs, an interrupt signal is generated (/INT status changes from Hi-Z to low). * When an alarm interrupt event occurs, low-level output from the /INT pin occurs only when the AIE bit value is "1". This value is retained (not automatically cleared) until the AF bit is cleared to zero.

8.5.3. Examples of alarm settings

- 1) Example of alarm settings when "Day" has been specified (and WADA bit = "0")

Table 54 Examples of alarm setting 1

Day is specified. WADA bit = "0"	Reg - A								Reg - 9	Reg - 8
	bit 7 AE	bit 6 S	bit 5 F	bit 4 T	bit 3 W	bit 2 T	bit 1 M	bit 0 S	HOUR Alarm	MIN Alarm
Monday through Friday, at 7:00 AM * Minute value is ignored	0	0	1	1	1	1	1	0	07 h	AE = 1
Every Saturday and Sunday, for 30 minutes each hour * Hour value is ignored	0	1	0	0	0	0	0	1	AE = 1	30 h
Every day, at 6:59 PM	0 1	1 X	1 X	1 X	1 X	1 X	1 X	1 X	18 h	59 h

X: Don't care.

- 2) Example of alarm settings when "Day" has been specified (and WADA bit = "1")

Table 55 Examples of alarm setting 2

Day is specified. WADA bit = "1"	Reg - A								Reg - 9	Reg - 8
	bit 7 AE	bit 6 •	bit 5 20	bit 4 10	bit 3 08	bit 2 04	bit 1 02	bit 0 01	HOUR Alarm	MIN Alarm
First of each month, at 7:00 AM * Minute value is ignored	0	0	0	0	0	0	0	1	07 h	AE = 1
15 th of each month, for 30 minutes each hour * Hour value is ignored	0	0	0	1	0	1	0	1	AE = 1	30 h
Every day, at 6:59 PM	1	X	X	X	X	X	X	X	18 h	59 h

X: Don't care.

8.6. The interrupt functions via /INT-pin or polling.

- 1) How to identify events, when the interruption was occurred.

/INT output pin is common output terminal of interrupt events of three types (Fixed-cycle timer interrupt, Alarm interrupt, Time update interrupt).

When INT asserted to Low, the system can determine in which interruption was occurred, by confirming status of (TF, AF, UF).

- 2) The method of detection of interruption with not using an INT output.

1. be left open INT.
2. be clears to 0 in TIE, AIE, and UIE bits.
3. monitor the TF, AF, UF. (Polling).

8.7. Temperature compensation function.

8.7.1. overview

During the production process of the RTC, we are programming the individual characteristics of the built-in crystal into the non-volatile memory of the RTC. The built-in temperature sensor measures the actual temperature of the module and compensates the oscillation frequency of the crystal oscillator using the stored compensation data. This way not only the time information is temperature compensated, but as well the FOUT signal, even when outputting 32.768kHz. This function works in the supply voltage range VTEM.

8.7.2. Related registers for temperature compensation function

Table 56 Temperature compensation Register

Address [h]	Function	bit 7	bit 6	bit 5	bit 4	bit 3	bit 2	bit 1	bit 0
0F,1F	Control Register	CSEL1	CSEL0	UIE	TIE	AIE	○	○	RESET

- 1) CSEL1, CSEL0 bit (Compensation Interval Select 1,0)

This bit sets an interval of a temperature compensation operation.

Current consumption decreases when increasing the Compensation Interval by means CSEL1,0. CSEL1,0 is set at the time of initial power-up to ("0","1") .

Table 57 CSEL bits

CSEL1	CSEL0	Compensation Interval
0	0	0.5 s
0	1	2.0 s
1	0	10 s
1	1	30 s

Even if the power supply voltage falls below VTEM and a VDET bit is set to "1", the temperature compensation operation is performed again if the supply voltage raises above VTEM.

8.8. Battery backup switchover function

8.8.1. Description of Battery backup switchover function

This function consists of a supply voltage detector "Voltage Detector", which detects if the main supply voltage " V_{DD} " drops below a threshold (V_{DET3}). During the voltage detection period, the built-in Pch-switch located between the main supply voltage pin " V_{DD} " and the backup power supply pin " V_{BAT} ". is opened. See Figure 8.13.

in case of $V_{DET3} < V_{DD}$, the RTC moves back into Normal Mode, else ($V_{DD} \leq V_{DET3}$) it switches into Backup Mode.

To be able to measure the supply voltage applied to V_{DD} -pin, the Pch-switch opens once every second and the diode stops current flows from V_{BAT} over the RTC into V_{DD} .

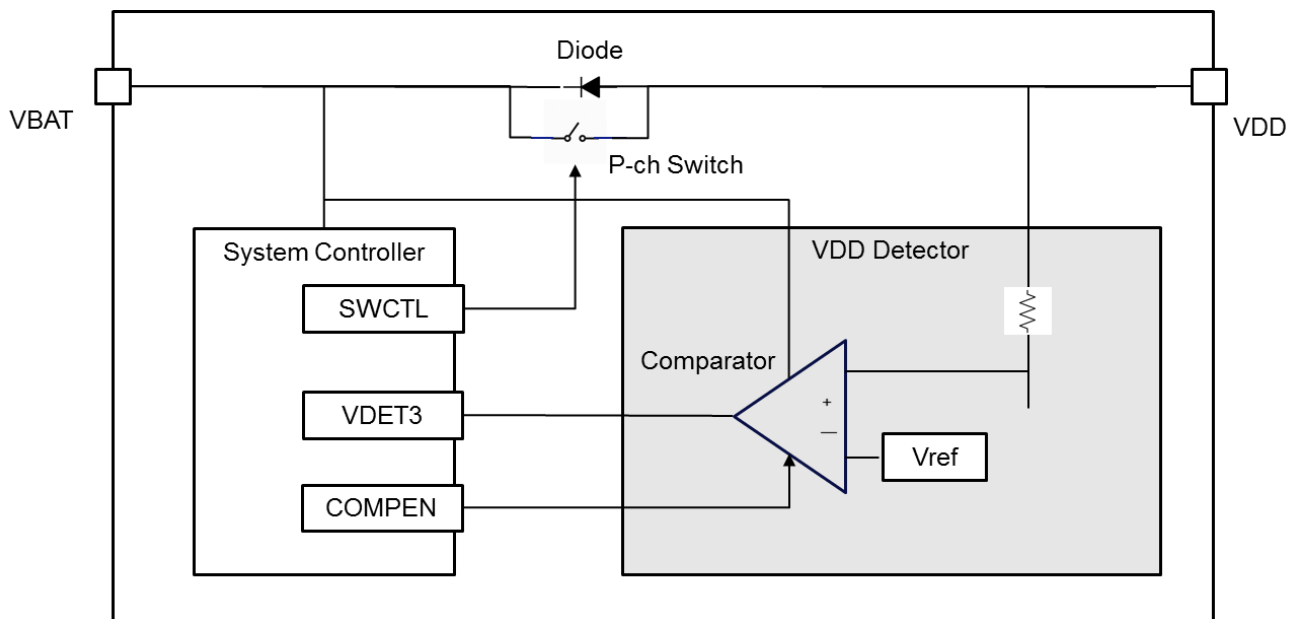

Figure 18 Battery Backup Switchover Block Diagram

8.8.2. The power switchover control.

To enable the battery backup switchover function, the voltage comparator (V_{DD} Detector) should be activated by means of the V_{DETOFF} bit. If $V_{DETOFF}=0$, the power switchover function is activated and in case $V_{DETOFF}=1$ this function is OFF.

In case the power switchover function is activated, the internal COMPEN signal is generated 62.5msec after the second counter incremented and thus the voltage comparator becomes active. The comparator active period (V_{DD} measurement period) is controlled through $BKSMP0$, $BKSMP1$ bits. There are two modes, $V_{DET3} < V_{DD}$ (Normal Mode), $V_{DD} \leq V_{DET3}$ (Backup Mode).

< Normal Mode >

V_{DD} voltage is detected every one second.

Comparator function intermittently ON, Pch-Switch intermittently OFF

In case of $V_{DD} \leq V_{DET3}$, it changes to Backup Mode.

< Backup Mode >

V_{DD} voltage is detected every one second.

Comparator function intermittently ON,

Pch-Switch is OFF anytime in Backup Mode.

In case of $V_{DET3} < V_{DD}$, it returns to Normal Mode.

RX8900 SA / CE

8.8.3. Battery Backup switchover related register.

Table 58 Battery Backup switchover related register.

Address	Function	bit 7	bit 6	bit 5	bit 4	bit 3	bit 2	bit 1	bit 0
18	Backup Function	○	○	○	○	VDET OFF	SWOFF	BKSMP1	BKSMP0

This register controls comparator, Pch-Switch, status and detection period.

8.8.4. Battery Backup switchover related register setting.

After power on reset, VDETOFF=0, SWOFF= 0, BKSMP0=0, BKSMP1=0 is set as default value.

So 1sec after power on reset, V_{DD} voltage is detected and goes to Normal Mode ($V_{DET3} < V_{DD}$) or Backup Mode ($V_{DD} \leq V_{DET3}$).

The duration of V_{DD} voltage detection is controlled by means of BKSMP0-bit, BKSMP1-bit and can be set to be 2msec, 16msec, 128msec or 256msec. V_{DD} voltage is detected at the end of this time, so at the falling edge of the comparator ON signal.

Table 59 Battery Backup switchover related register setting

V_{DD} detector	VDETOFF	SWOFF	BKSMP1	BKSMP0	VDET3 Sampling operation period	Pch-Switch ON/OFF	Remarks
ON	0	X	0	0	2ms	2ms OFF	VDETOFF:0, BKSMP1 = BKSMP0 = 0. Default
			0	1	16ms	16ms OFF	
			1	0	128ms	128ms OFF	
			1	1	256ms	256ms OFF	
OFF	1	0	X	X	OFF	ON	V_{DD} and VBAT short circuit via Pch-switch
		1	X	X	OFF	OFF	V_{DD} connected. via diode to V_{BAT}

X = Don't care.

8.8.5. Disabled functions in backup mode

Note: In backup mode, the following functions doesn't work due to the voltage down of the main power supply V_{DD} to drive I/O terminals.

Table 60 Function status in Backup mode

Function	Status
I ² C Interface	Not available.
Alarm interruption	/IRQ is always Hi-Z. AF, TF, UF are works normally.
Timer interruption	
Time update interruption	
FOUT output	FOUT is always Low.
V_{BAT} low detection	Detection works always.
Temperature compensation	Same as normal mode. VBAT or V_{DD} need more than VTEM (3.0V Typ.).

8.8.5. Reference characteristics of Diode and Pch-Switch.

Table 61 Diode (between VBAT from VDD) reference characteristics

Item	Characteristics	Condition
Pch-Switch rated current	40 mA(Max.).	VDD = 3.0 V, Pch-SW = On, +25 degree C
Diode forward voltage V_F	0.75 V / 1 mA. (Typ.) 0.92V / 10mA. (Typ.)	VDD = 3.0 V, Pch-SW = Off +25 degree C
Diode reverse current I_R	Less than 4 nA	VDD = 5.5 V -40 to +85 degree C

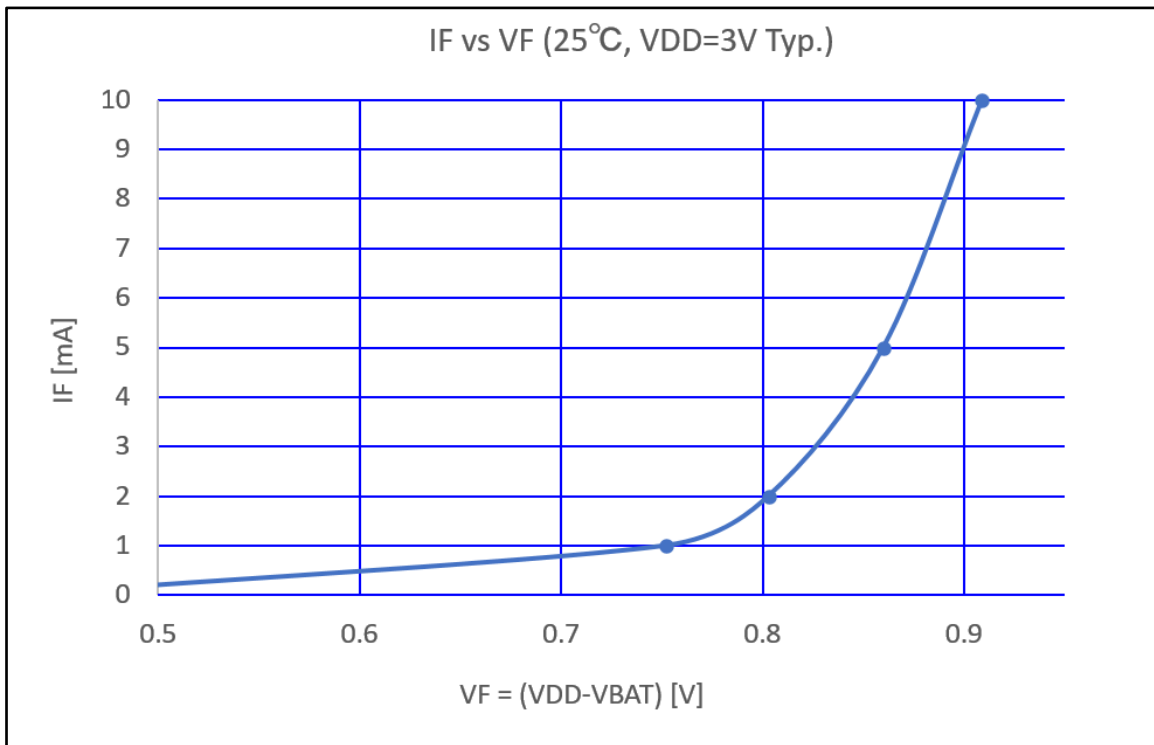

Figure 19 IF vs VF reference characteristics.

Condition: Pch-SW is Off (Open).

This characteristics applies only to internal diode.

When Pch-SW is On (Close), VF is canceled.

8.8.6. Mode flow of the battery backup switchover function.

V_{DD} drop below VDET3 can only be detected while the Pch-Switch is OFF (Comparator is enabled.).

In case a V_{DD} drop below VDET3 is detected, the Pch-Switch stays OFF (open), and RTC enters Backup-mode.

When V_{DD} is detected to be higher than VDET3, the Pch-Switch switches back to ON (closed), and RTC remains or enters Normal-mode.

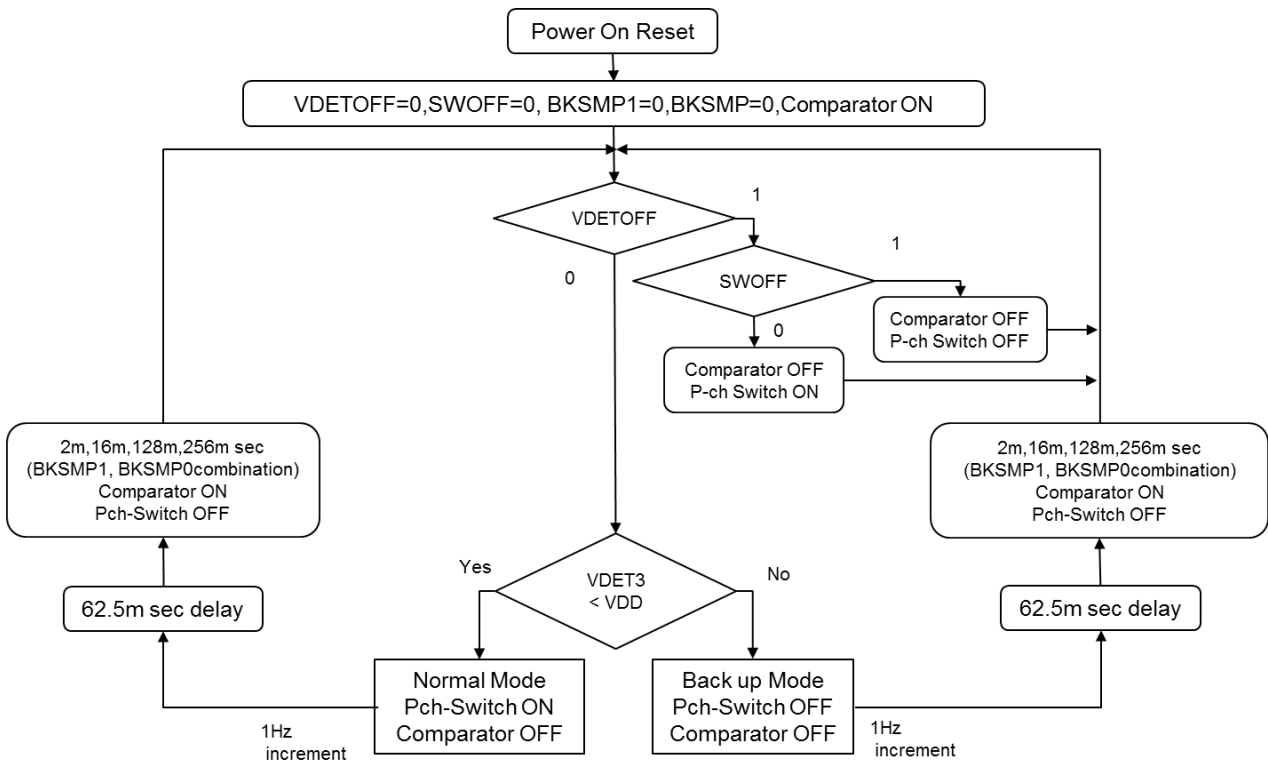

Figure 20 Mode flow of the backup power supply switchover function.

8.8.7. The pros and cons of detection period (2msec, 16msec,128msec and 256msec)

Since a V_{DD} drop below V_{DET3} is only detected while the Pch-switch is open, user should carefully set the V_{DD} detection period (by means of BKSMP0 and BKSMP1) to make sure the V_{DD} voltage applied to the RTC V_{DD} -pin falls below the V_{DET3} threshold during this time.

Table 62 The pros and cons of detection period setting.

Term	V_{DD} voltage detection period		Remarks
	[2 ms]	~ [256 ms]	
Current consumption (Normal Mode)	small	large	Longer detecting period increases V_{DD} Detector current consumption.
Backup battery Charging effectiveness (Normal Mode)	Smaller detection period makes better charging effectiveness.		During detection period, Backup battery is charged through Diode.
Actual V_{DD} voltage detecting period (Normal Mode)	Smaller detection period is better for slower V_{DD} falling.	Longer detection period is better for prompt V_{DD} falling.	Voltage detection is possible during detection period. (See Figure 8.16, Figure 8.17)

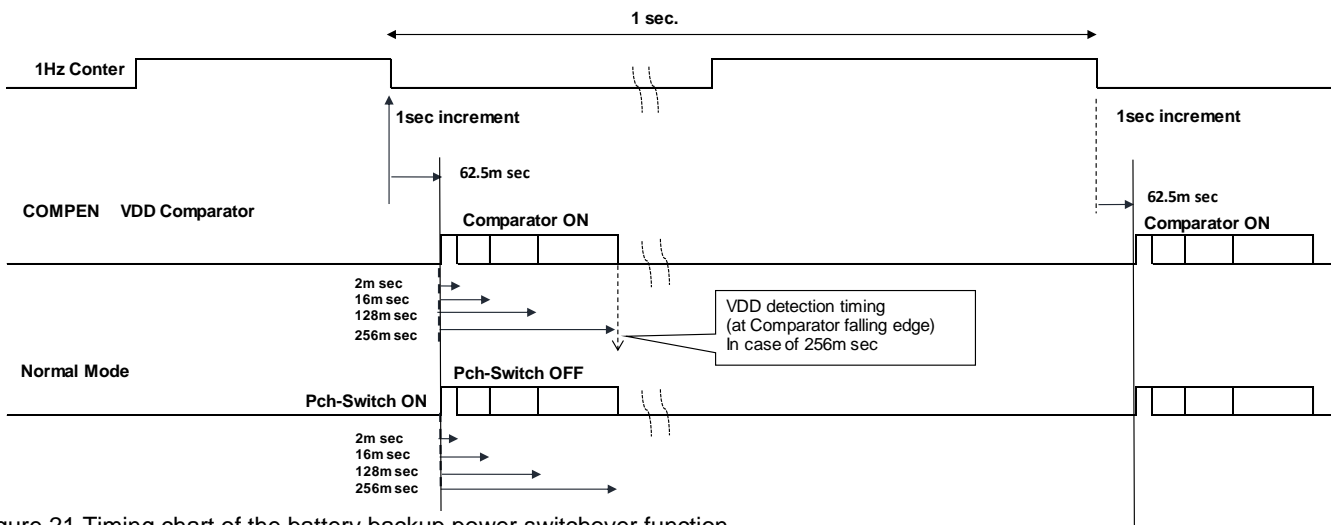

Figure 21 Timing chart of the battery backup power switchover function

RX8900 SA / CE

If the voltage detection period is not set long enough by means of BKSMP0 and BKSMP1, a steep V_{DD} voltage drop might not be detected and thus the backup power supply is discharged into V_{DD}. Between the voltage detection periods once per second, the Pch-switch is closed and thus the backup power supply discharges into V_{DD} as well. To avoid this backup battery discharge, a diode might be set between V_{DD} pin to power line. (See 8.8.7 Ex.4)

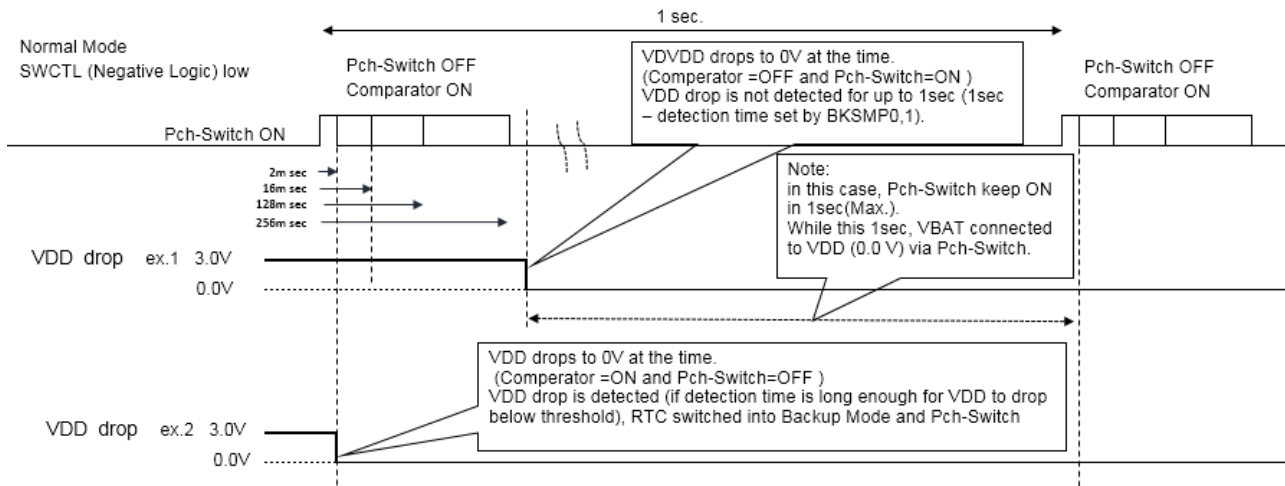

Figure 22 V_{DD} drop detection 1

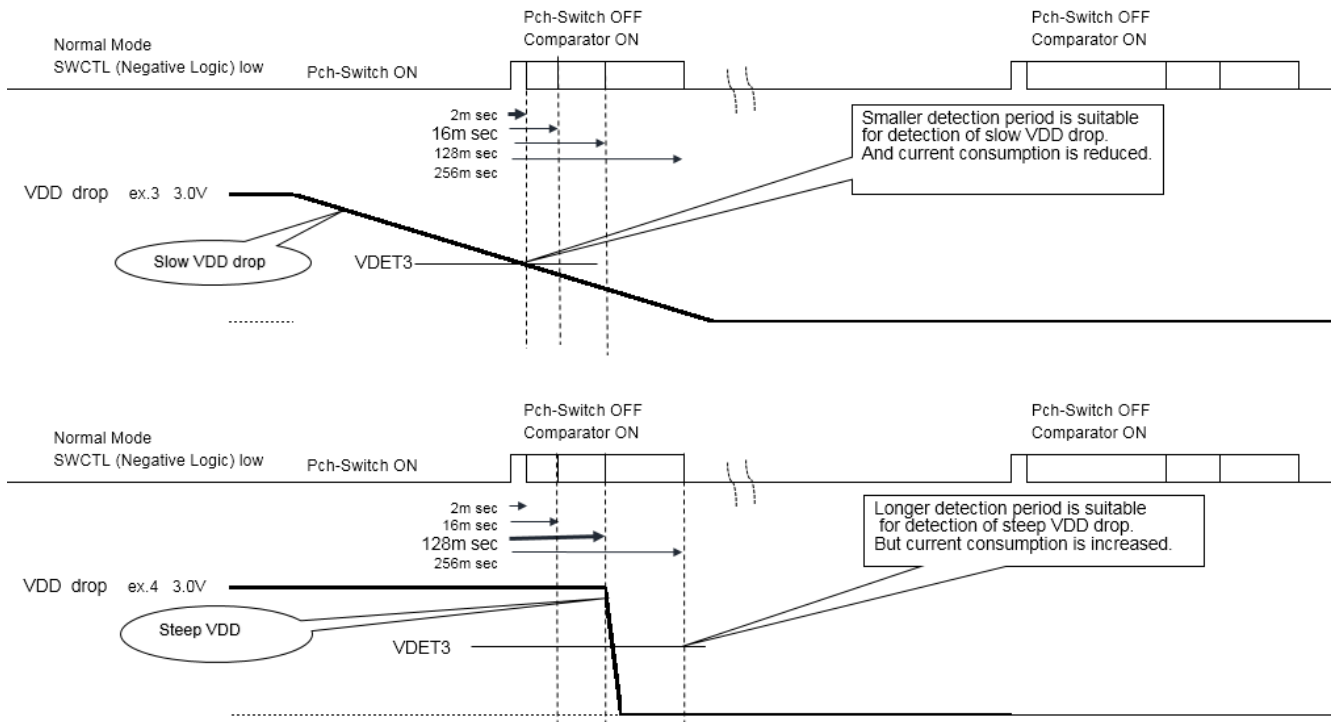

Figure 23 . V_{DD} drop detection 2

RX8900 SA / CE

8.8.7 Connection examples

Figure 24 Ex-1 Single power supply.

External supply should be connected to both V_{DD} and V_{BAT}.
In this case, interface (I²C, FOUT) are active in a supply voltage range from 1.6V to 5.5V anytime.

Address	Bit 7	Bit 6	Bit 5	Bit 4	Bit 3	Bit 2	Bit 1	Bit 0
18h	○	○	○	○	VDET OFF	SWOFF	BKSMP1	BKSMP0
Data	0	0	0	0	1	X	X	X

Parts
X = Don't care.
C = 0.1uF

Figure 25 Ex-2 Non- rechargeable battery. ex. CR2032, AAA.

When V_{DD} shut to OFF,
Battery current is leak to V^{DD}(0.0V) while 1sec(Max.).
Refer Figure 8.16.

Address	Bit 7	Bit 6	Bit 5	Bit 4	Bit 3	Bit 2	Bit 1	Bit 0
18h	○	○	○	○	VDET OFF	SWOFF	BKSMP1	BKSMP0
Data	0	0	0	0	0	0	X	X

Parts
C = 0.1uF.(Typ.)
R : Recommended less than 100 Ω
D = Schottky Barrier type

Figure 26 Ex-3 Rechargeable battery. EDLC, etc.

In this case, the current limiting resistor on the V_{BAT} should be set not to exceed 40 mA (Max.). Bigger resistor value might make the supply voltage of the RTC to drop below V_{LOW} or V_{DET} at the time of power-switchover.
When a higher resistor value is required to control the charging current to EDLC, or while 1sec(Max.), current leak into V_{DD}(0.0V) from V_{BAT} is so serious in system, it is recommended to use connection example Ex.4.

Address	Bit 7	Bit 6	Bit 5	Bit 4	Bit 3	Bit 2	Bit 1	Bit 0
18h	○	○	○	○	VDET OFF	SWOFF	BKSMP1	BKSMP0
Data	0	0	0	0	0	0	X	X

Parts
C = 0.1uF. (Typ.)
R = the current limiting resistor should be set not to exceed 40 mA.
X bit = Don't care.

Figure 27 Ex-4 For using high value protection resistor.

This circuit is recommended in case a current flow for up to 1 sec from V_{BAT} into V_{DD}, before entering backup-mode is not acceptable or in case the charging current of the EDLC or Recommended when using high resistance values to reduce the charging current of EDLCs or rechargeable batteries to very low values.
Ex, more than 500 ohm etc.

Address	Bit 7	Bit 6	Bit 5	Bit 4	Bit 3	Bit 2	Bit 1	Bit 0
18h	○	○	○	○	VDET OFF	SWOFF	BKSMP1	BKSMP0
Data	0	0	0	0	1	0	X	X

Parts
C = 0.1uF. (Typ.)
R: The current limiting resistor should be set not to exceed 40 mA.
D = Schottky Barrier type.
X bit = Don't care

8.8.8 Note: Diode characteristics.

For example.

In connection Example 2, V_{DD} is 3.3V and CR2032 is 3.0V.
 when VF of RTC's Diode is 0.6V, out of RTC's Diode is 2.7V.
 and VF of outside Diode is 0.2V, VBAT voltage is 2.8V.
 In this case, even if V_{DD} is active, RTC use 2.8V from CR2032 anytime.
 as a results, CR2032 life very shorten than an assumption.
 In a choice of a diode, consider balance of the voltage carefully.

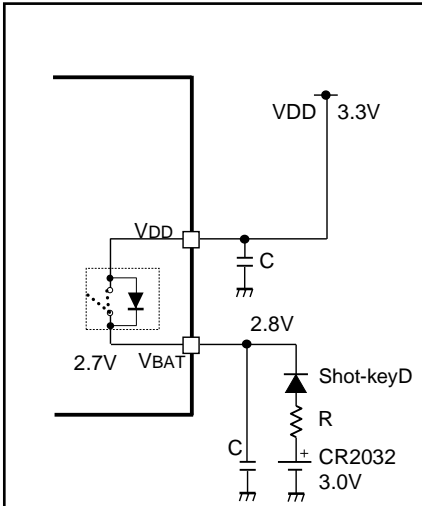

Figure 28 Note of diode VF.

Example of solution for above.
 A Schottky diode(D2) is installed in a V_{DD} side.
 and RTC's diode is bypassed.
 Therefore, voltage drop of V_{DD} depends on only V/F of D2.
 As a result, examination of simple circuitry is possible.

Figure 29 Ex-5 Diode OR circuit.									
it just Diode-OR-circuit Confirm each of V/F characteristics carefully.									
Address	Bit 7	Bit 6	Bit 5	Bit 4	Bit 3	Bit 2	Bit 1	Bit 0	
18h	○	○	○	○	VDET OFF	SWOFF	BKSMP1	BKSMP0	
Data	0	0	0	0	1	0	X	X	
Parts	X Bit = Don't care. C = 0.1uF. R : Recommended less than 100Ω D1 & D2 = Schottky Barrier type. To avoid a wasted leakage current. When V_{DD} is OFF, I/R characteristics of Diode(D2) is important. Confirm IR characteristics of Diode with Temp characteristics.								

8.9. Reading/Writing Data via the I²C Bus Interface

8.9.1. Overview of I²C-BUS

The I²C bus supports bi-directional communications via two signal lines: the SDA (data) line and SCL (clock) line. A combination of these two signals is used to transmit and receive communication start/stop signals, data transfer signals, acknowledge signals, and so on.

Both the SCL and SDA signals are held at high level whenever communications are not being performed. The starting and stopping of communications is controlled at the rising edge or falling edge of SDA while SCL is at high level.

During data transfers, data changes that occur on the SDA line are performed while the SCL line is at low level, and on the receiving side the data is output while the SCL line is at high level.

The I²C bus device does not include a chip select pin such as is found in ordinary logic devices. Instead of using a chip select pin, slave addresses are allocated to each device and the receiving device responds to communications only when its slave address matches the slave address in the received data. In either case, the data is transferred via the SCL line at a rate of one bit per clock pulse.

8.9.2. System configuration

All ports connected to the I²C bus must be either open drain or open collector ports in order to enable AND connections to multiple devices.

SCL and SDA are both connected to the VDD line via a pull-up resistance. Consequently, SCL and SDA are both held at high level when the bus is released (when communication is not being performed).

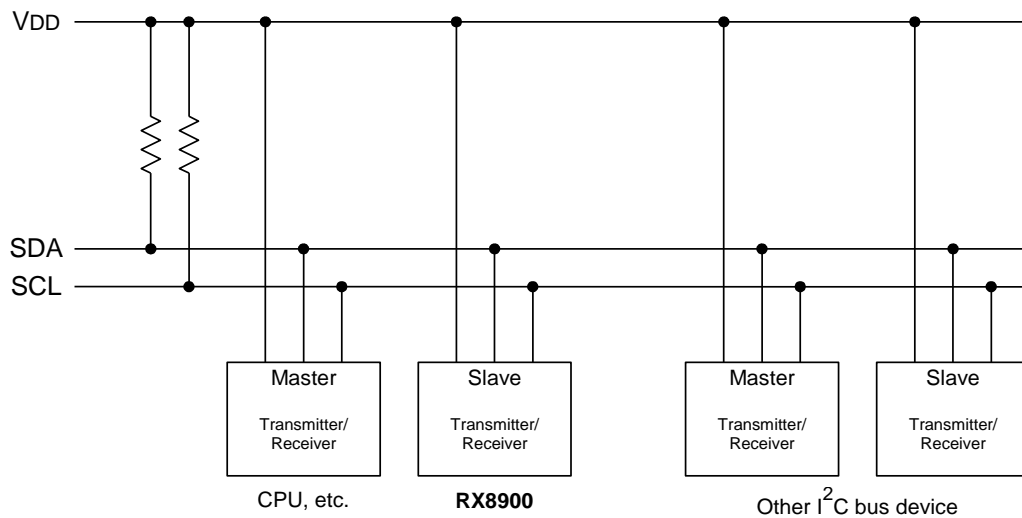

Figure 30 I²C bus connection.

Any device that controls the data transmission and data reception is defined as a "Master".

and any device that is controlled by a master device is defined as a "Slave".

The device transmitting data is defined as a "Transmitter" and the device receiving data is defined as a receiver"

In the case of this RTC module, controllers such as a CPU are defined as master devices and the RTC module is defined as a slave device. When a device is used for both transmitting and receiving data, it is defined as either a transmitter or receiver depending on these conditions.

8.9.3. Starting and stopping I²C bus communications

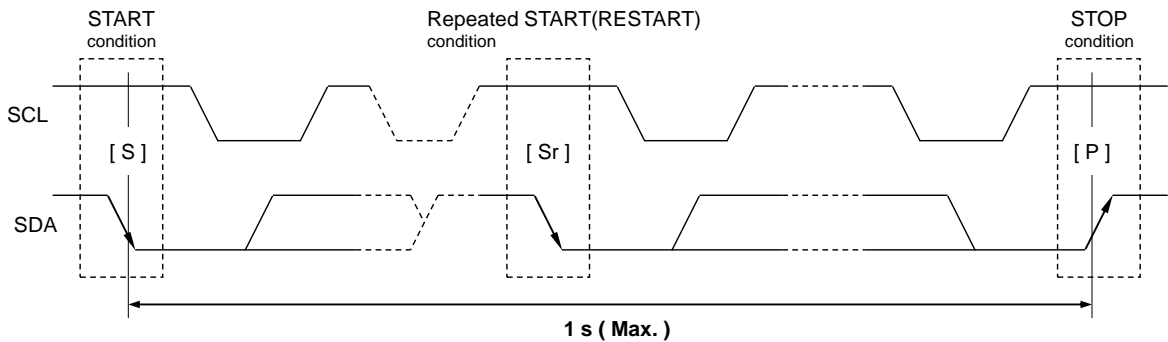

Figure 31 I²C bus START, RESTART timing.

1) START condition, repeated START condition, and STOP condition

(1) START condition

- The SDA level changes from high to low while SCL is at high level.

(2) STOP condition

- This condition regulates how communications on the I²C-BUS are terminated. The SDA level changes from low to high while SCL is at high level.

(3) Repeated START condition (RESTART condition)

- In some cases, the START condition occurs between a previous START condition and the next STOP condition, in which case the second START condition is distinguished as a RESTART condition. Since the required status is the same as for the START condition, the SDA level changes from high to low while SCL is at high level.

2) Caution points

- *1) The master device always controls the START, RESTART, and STOP conditions for communications.
- *2) The master device does not impose any restrictions on the timing by which STOP conditions affect transmissions, so communications can be forcibly stopped at any time while in progress. (However, this is only when this RTC module is in receiver mode (data reception mode = SDA released).)
- *3) When communicating with this RTC module, the series of operations from transmitting the START condition to transmitting the STOP condition should occur **within 0.95 seconds**. (A RESTART condition may be sent between a START condition and STOP condition, but even in such cases the series of operations from transmitting the START condition to transmitting the STOP condition should still occur **within 0.95 seconds**.)

If this series of operations requires **0.95 seconds or longer**, the I²C bus interface will be automatically cleared and set to standby mode by this RTC module's bus timeout function. Note with caution that both write and read operations are invalid for communications that occur during or after this auto clearing operation. (When the read operation is invalid, all data that is read has a value of "1"). Restarting of communications begins with transfer of the START condition again

- *4) When communicating with this RTC module, wait **at least 1.3 μs (see the tBUF rule)** between transferring a STOP condition (to stop communications) and transferring the next START condition (to start the next round of communications).

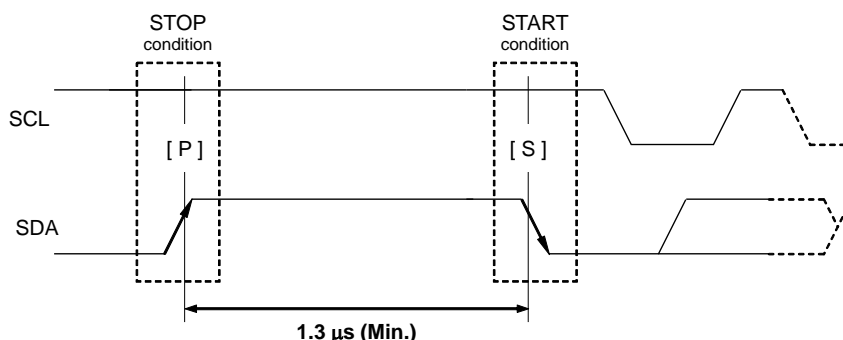

Figure 32 I²C bus START STOP condition

8.9.4. Data transfers and acknowledge responses during I²C-BUS communications

1) Data transfers

Data transfers are performed in 8-bit (1 byte) units once the START condition has occurred. There is no limit on the amount (bytes) of data that are transferred between the START condition and STOP condition. **(However, the transfer time must be no longer than 0.95 seconds.)**

The address auto increment function operates during both write and read operations.

After address 0Fh, incrementation goes to address 00h.

Updating of data on the transmitter (transmitting side)'s SDA line is performed while the SCL line is at low level. The receiver (receiving side) receives data while the SCL line is at high level.

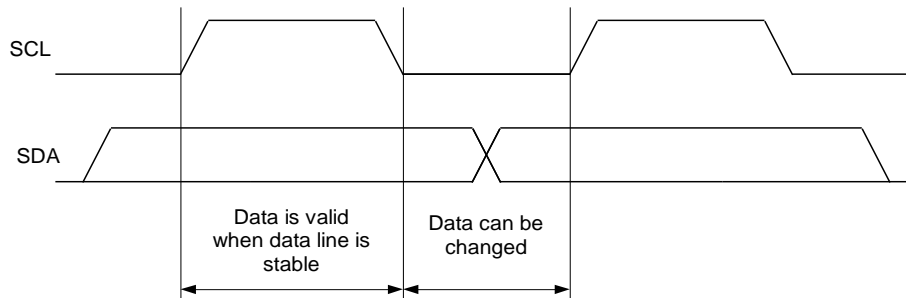

Figure 33 I²C bus data transfer

* Note with caution that if the SDA data is changed while the SCL line is at high level, it will be treated as a START, RESTART, or STOP condition.

2) Data acknowledge response (ACK signal)

When transferring data, the receiver generates a confirmation response (ACK signal, low active) each time an 8-bit data segment is received. If there is no ACK signal from the receiver, it indicates that normal communication has not been established. (This does not include instances where the master device intentionally does not generate an ACK signal.)

Immediately after the falling edge of the clock pulse corresponding to the 8th bit of data on the SCL line, the transmitter releases the SDA line and the receiver sets the SDA line to low (= acknowledge) level.

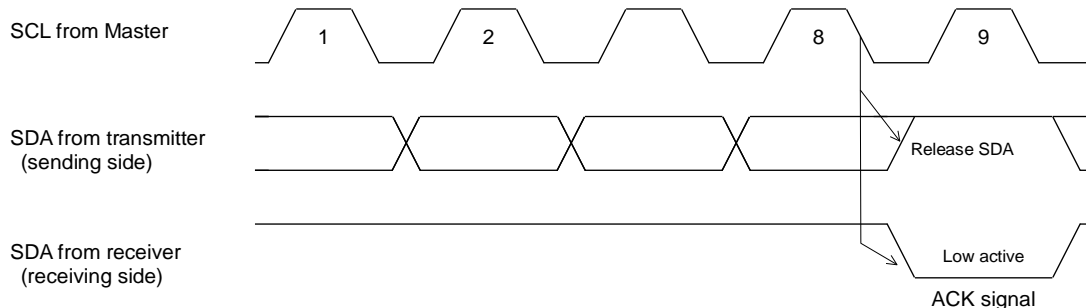

Figure 34 I²C bus data acknowledge response

After transmitting the ACK signal, if the Master remains the receiver for transfer of the next byte, the SDA is released at the falling edge of the clock corresponding to the 9th bit of data on the SCL line. Data transfer resumes when the Master becomes the transmitter.

When the Master is the receiver, if the Master does not send an ACK signal in response to the last byte sent from the slave, that indicates to the transmitter that data transfer has ended. At that point, the transmitter continues to release the SDA and awaits a STOP condition from the Master.

8.9.5. Slave address

The I²C bus device does not include a chip select pin such as is found in ordinary logic devices. Instead of using a chip select pin, slave addresses are allocated to each device.

All communications begin with transmitting the [START condition] + [slave address (+ R/W specification)]. The receiving device responds to this communication only when the specified slave address it has received matches its own slave address.

Slave addresses have a fixed length of 7 bits. This RTC's slave address is **[0110 010*]**.
 An R/W bit ("*" above) is added to each 7-bit slave address during 8-bit transfers.

Table 63 I²C Bus Slave address

	Transfer data	Slave address							R/W bit
		bit 7	bit 6	bit 5	bit 4	bit 3	bit 2	bit 1	bit 0
Read	65 h	0	1	1	0	0	1	0	1 (= Read)
Write	64 h								0 (= Write)

8.9.6 I²C bus protocol

In the following sequence descriptions, it is assumed that the CPU is the master and the RX8900 is the slave.

8.9.6.1. Address specification write sequence

Since the RX8900 includes an address auto increment function, once the initial address has been specified, the RX8900 increments (by one byte) the receive address each time data is transferred.

- (1) CPU transfers start condition [S].
- (2) CPU transmits the RX8900's slave address with the R/W bit set to write mode.
- (3) Check for ACK signal from RX8900.
- (4) CPU transmits write address to RX8900.
- (5) Check for ACK signal from RX8900.
- (6) CPU transfers write data to the address specified at (4) above.
- (7) Check for ACK signal from RX8900.
- (8) Repeat (6) and (7) if necessary. Addresses are automatically incremented.
- (9) CPU transfers stop condition [P].

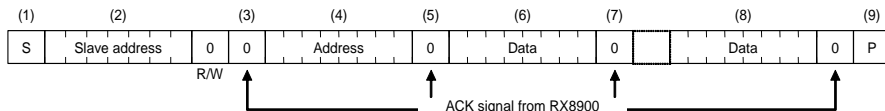

Figure 35 Address specification write sequence

8.9.6.2. Address specification read sequence

After using write mode to write the address to be read, set read mode to read the actual data.

- (1) CPU transfers start condition [S].
- (2) CPU transmits the RX8900's slave address with the R/W bit set to write mode.
- (3) Check for ACK signal from RX8900.
- (4) CPU transfers address for reading from RX8900.
- (5) Check for ACK signal from RX8900.
- (6) CPU transfers RESTART condition [Sr] (in which case, CPU does not transfer a STOP condition [P]).
- (7) CPU transfers RX8900's slave address with the R/W bit set to read mode.
- (8) Check for ACK signal from RX8900 (from this point on, the CPU is the receiver and the RX8900 is the transmitter).
- (9) Data from address specified at (4) above is output by the RX8900.
- (10) CPU transfers ACK signal to RX8900.
- (11) Repeat (9) and (10) if necessary. Read addresses are automatically incremented.
- (12) CPU transfers ACK signal for "1".
- (13) CPU transfers stop condition [P].



Figure 36 Address specification read sequence

8.9.6.3. Read sequence when address is not specified

Once read mode has been initially set, data can be read immediately. In such cases, the address for each read operation is the previously accessed address + 1.

- (1) CPU transfers start condition [S].
- (2) CPU transmits the RX8900's slave address with the R/W bit set to read mode.
- (3) Check for ACK signal from RX8900
(from this point on, the CPU is the receiver and the RX8900 is the transmitter).
- (4) Data is output from the RX8900 to the address following the end of the previously accessed address.
- (5) CPU transfers ACK signal to RX8900.
- (6) Repeat (4) and (5) if necessary. Read addresses are automatically incremented in the RX8900.
- (7) CPU transfers ACK signal for "1".
- (8) CPU transfers stop condition [P].

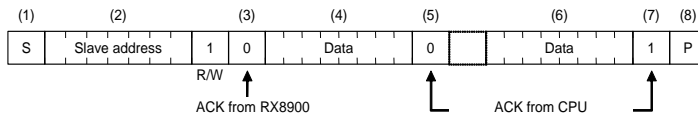

Figure 37. Read sequence when address is not specified

8.9.6.4. The address auto increment in Read/Write.

- (1) In Basic time and calendar register.
Address 08 . 09 . 0A . 0B . 0C . 0D . 0E . 0F . 00 . 01 . 02 . .
- (2) In Extension register
Address - 18 - 19 - 1A - 1B - 1C - 1D - 1E - 1F - 10 - 11 - 12 - .

8.10. Backup and Recovery

- *This circuit is sensitive to power supply noise and supply voltage should be stabilized to avoid negative impact on the accuracy.
- * tR1 is needed for a proper power-on reset. If this power-on condition cannot be kept, it is necessary to send an initialization routine to the RTC by software.
- *In case of repeated ON/OFF of the power supply within short term, it is possible that the power-on reset becomes unstable.
- After power-OFF, keep V_{DD}=V_{BAT}=GND for more than 10 seconds for a proper power-on reset.
- When Power-on-reset is uncertainty, system can initialize the RTC by the software.
- * When a controller goes to shutdown, a CPU sent STOP condition to RTC, then that I²C communication is complete status is recommended.

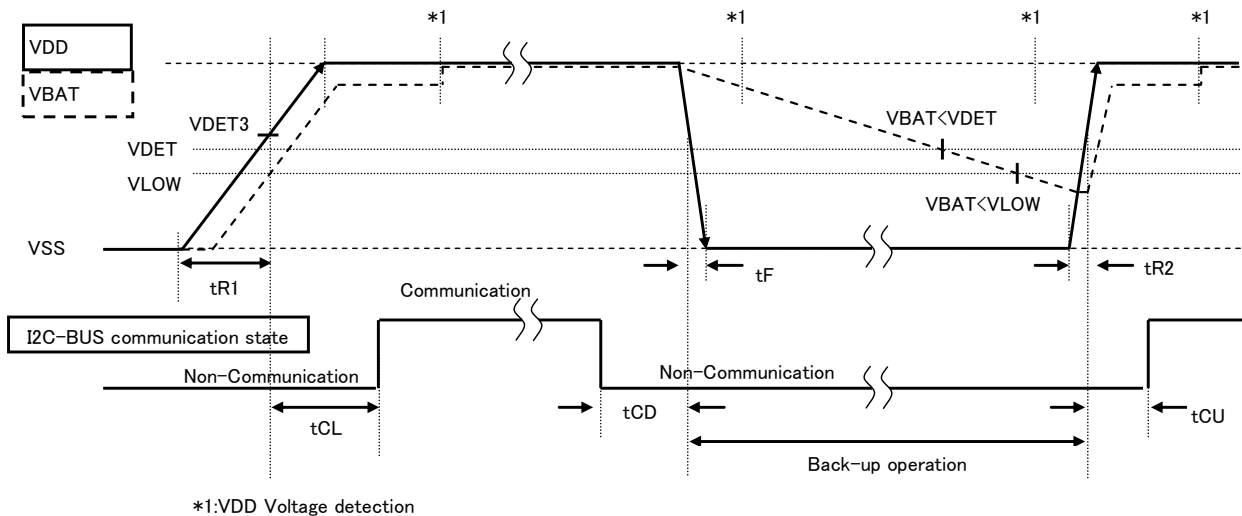

Figure 38. Backup and Recovery sequence

RX8900 SA / CE

Table 64 Power supply, detection voltage

Item	Symbol	Condition	Min.	Typ.	Max.	Unit.
Detection voltage (1) VDET-bit threshold	VDET	-	1.9	1.95	2.0	V
Detection voltage (2) VLF-bit threshold	VLOW	-	1.16	-	1.6	V
Detection voltage (3) Backup-switchover voltage	VDET3	-	2.3	2.4	2.5	V
Power supply rise time1	tR1	V _{DD} =GND to 2.5V	1	-	10	ms / V
Access wait time (After initial power on)	tCL	After V _{DD} =2.5V	30	-	-	ms
Access disable hold time	tCD	After stop condition	0	-	-	μs / V
Power supply fall time	tF	V _{DD} =2.5V to GND	2	-	-	μs / V
Power supply rise time2	tR2	V _{DD} =V _{SS} to 2.5V	15	-	-	μs / V
Access wait time (Normal power on)	tCU	After V _{DD} =2.5V	0	-	-	μs

* :tR2 is specifications for an oscillation not to stop. Some clocks are not output by an FOUT terminal.

8.11. The note of access to RTC at the time of backup return and initial power supply

Because most of RTC registers are synchronized with the oscillation clock of the built-in crystal oscillator, the RTC does not work normally without the integrated oscillator having stabilized.

- 1) The first, System should confirm status of VLF-bit.
- 2) When VLF is "1", system must initialize all of registers.
- 3) When initial-power-ON was given to RTC, wait for tSTA(3seconds) for setup of time and Calendar.
But readout access is permitted after 30ms from V_{DD}=VCLK.

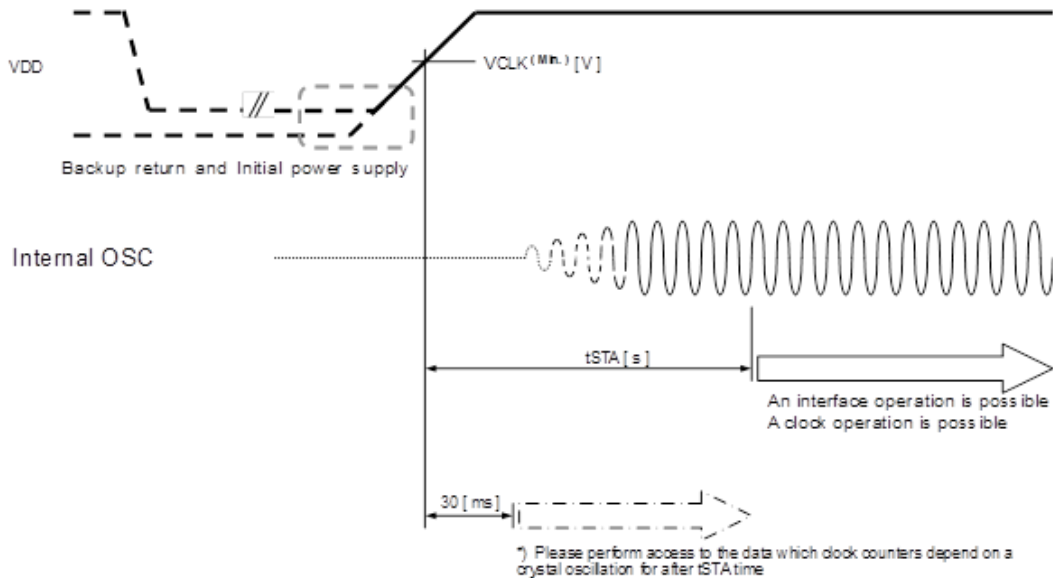

Figure 39 Oscillation starting sequence.

8.12. Flow chart

The following flow-chart is one example, but it is not necessarily applicable for every use-case and not necessarily the most effective process for individual applications.

1) An example of the initialization Ex.1 Initialize

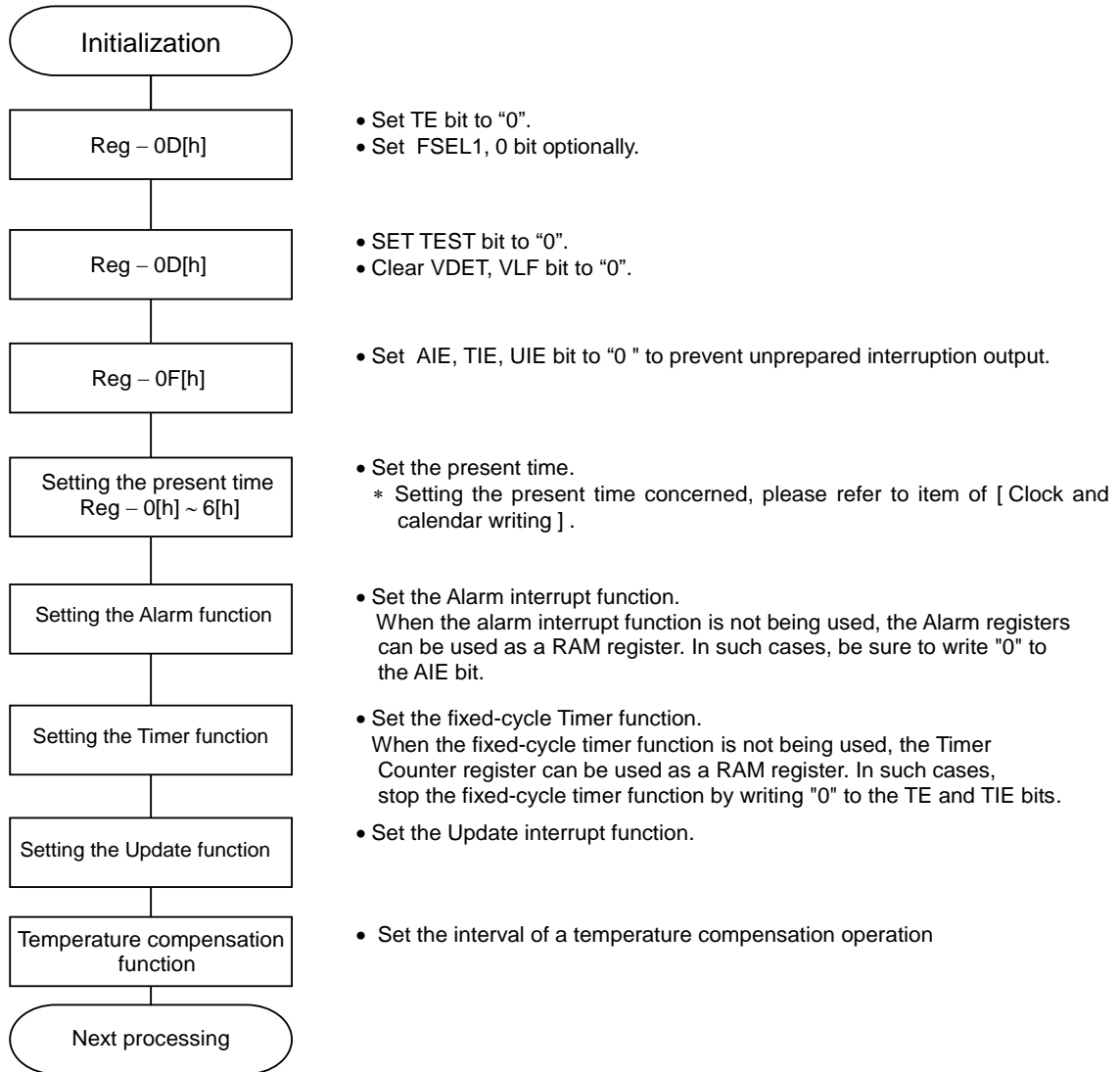
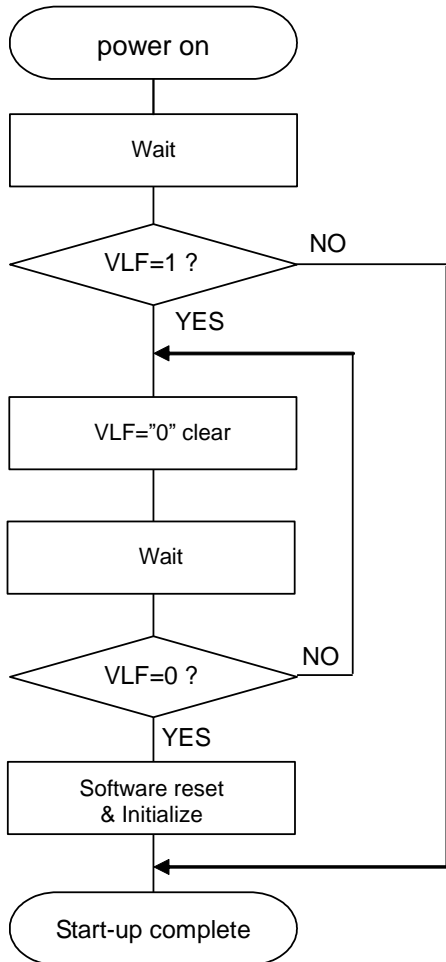

Figure 40 An example of the initialization

2) Method of initialization after starting of internal oscillation (VLF stays "0")



- Wait time of 30ms is necessary at least
- Whether it is a return from the state of the backup is confirmed.
- When an internal oscillation starts, 0 writing of VLF is approved.
- Please set waiting time depending on load of a system optionally

Figure 41 Method of initialization after starting of internal oscillation.

3) The setting of the clock and calendar

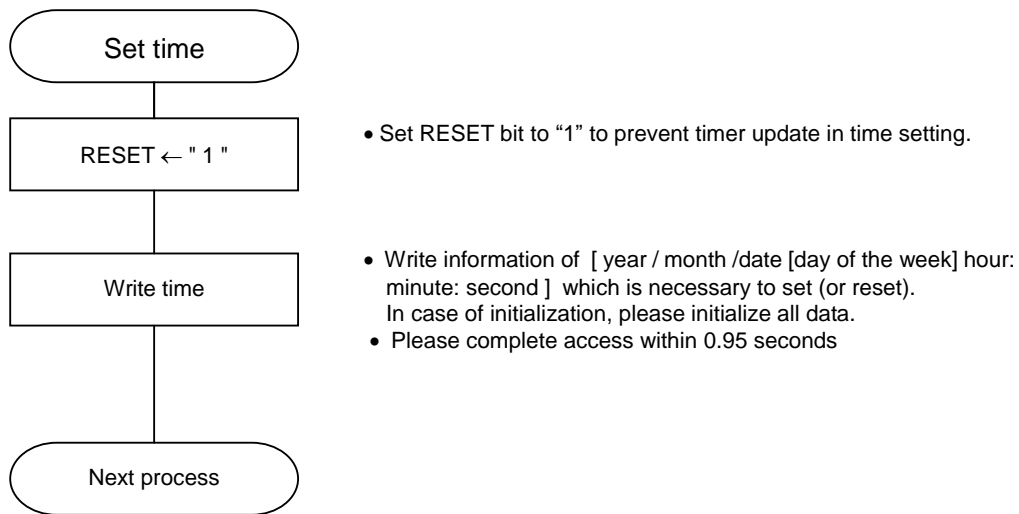

Figure 42 The setting of the clock and calendar

4) The reading of the clock and calendar

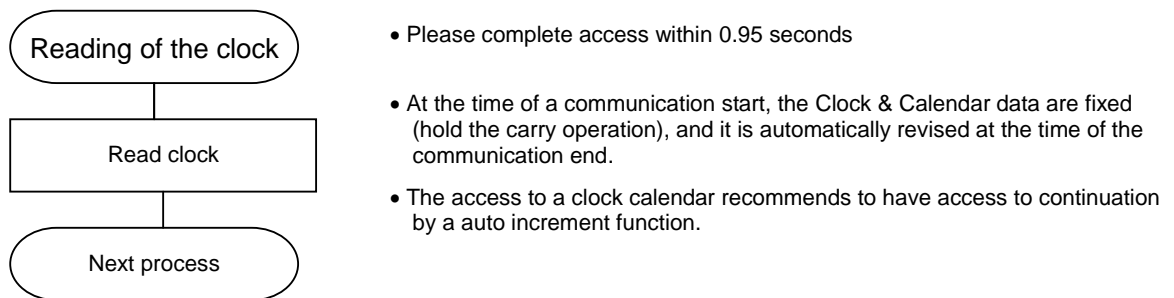

Figure 43 The reading of the clock and calendar

RX8900 SA / CE

8.13. Connection example with Typical Microcontroller

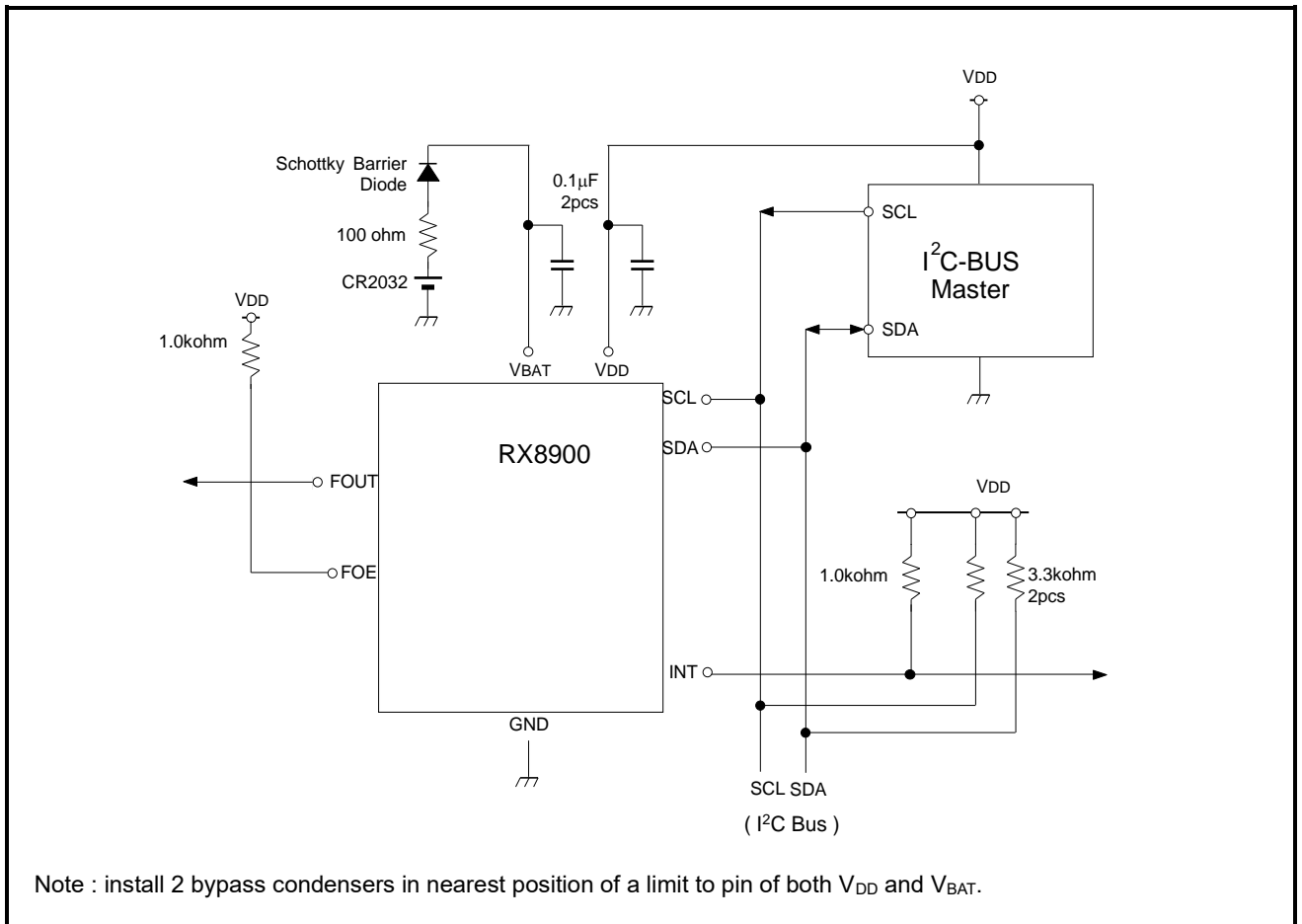

Figure 44 Connection example with Typical Microcontroller

8.14. Connection RTC used as a 32.768 kHz TCXO

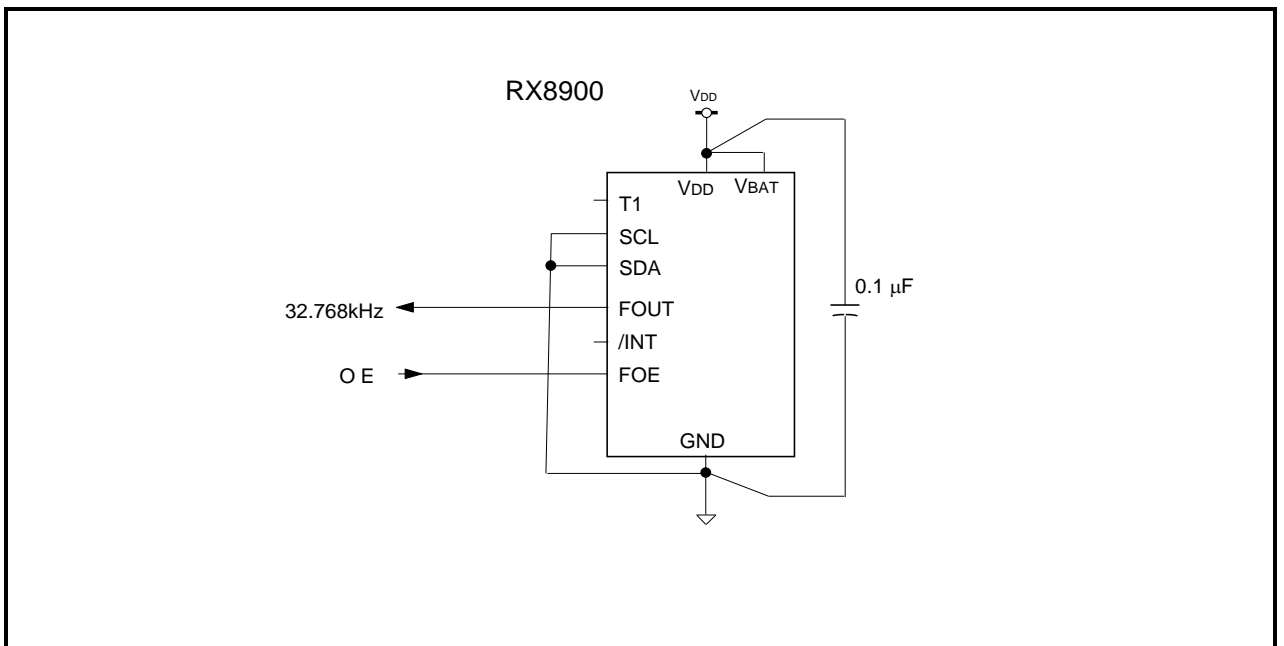

Figure 45 Connection RTC used as a 32.768 kHz TCXO.

RX8900 SA / CE

9. External Dimensions Marking Layout

9.1. RX8900SA

9.1.1. External dimensions

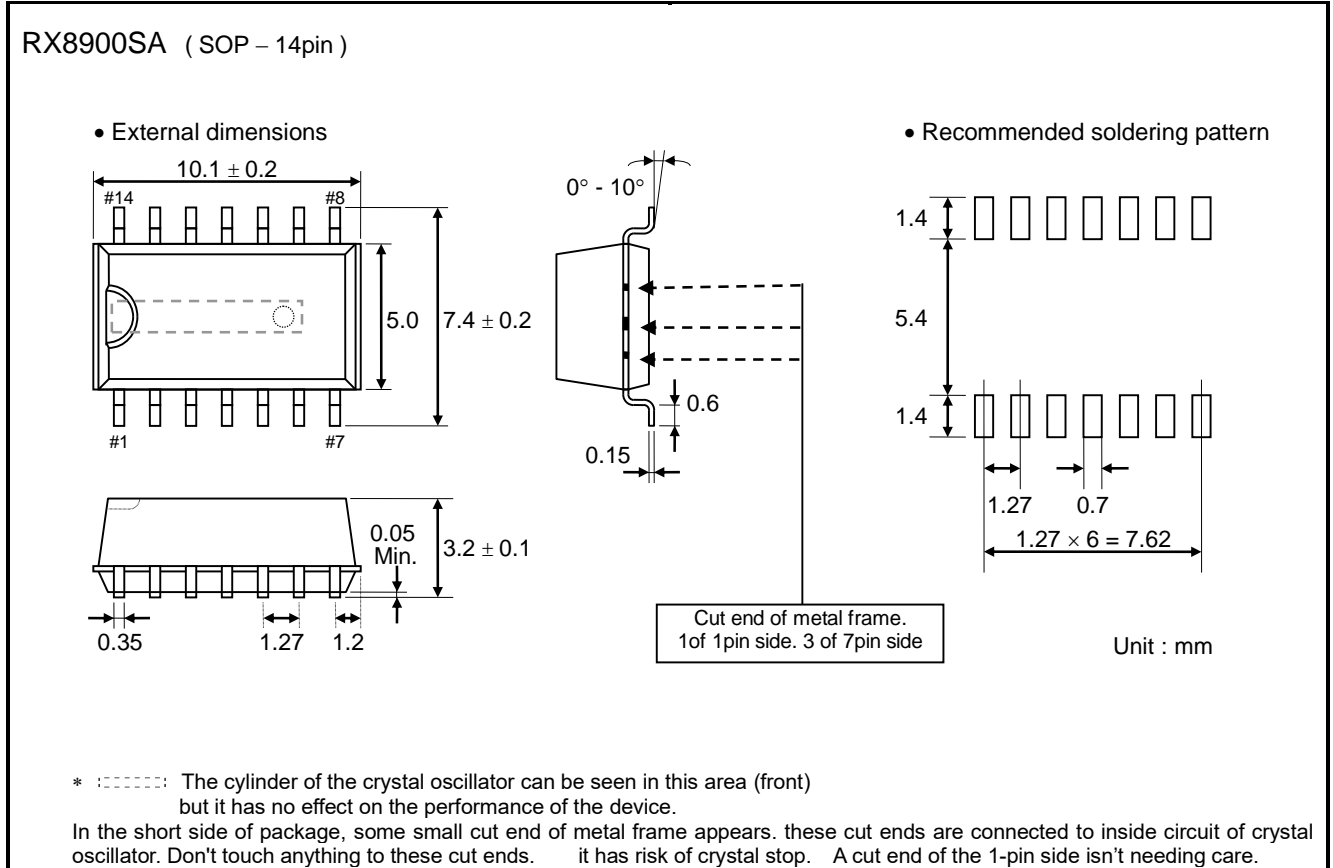

Figure 46 RX8900SA package

9.1.2. RX8900SA Marking layout

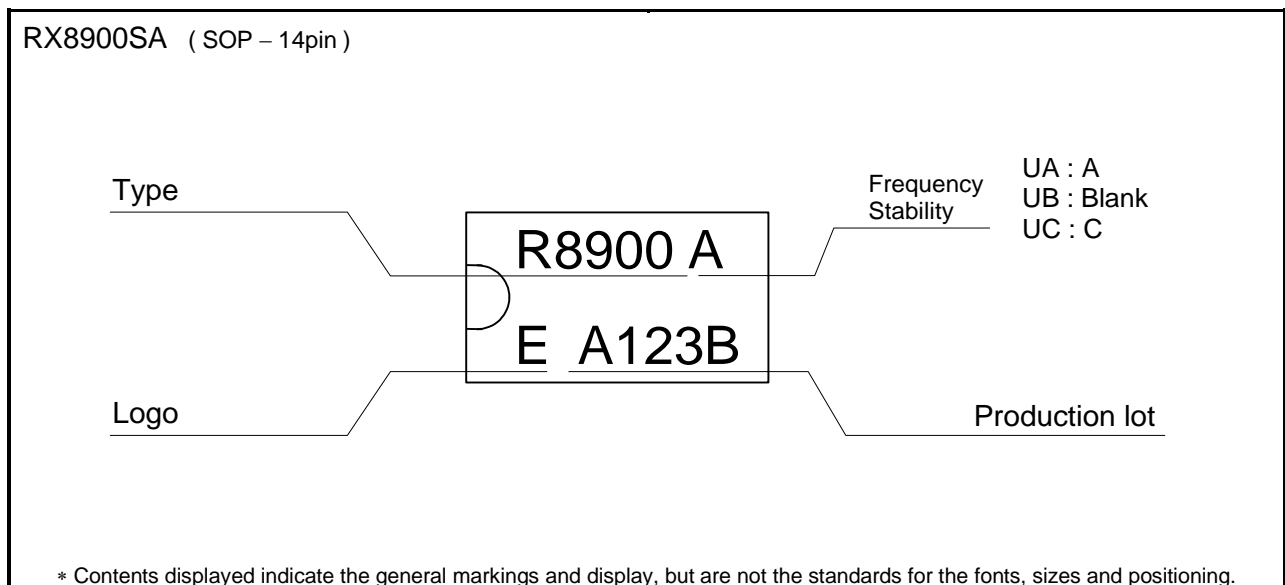

Figure 47 RX8900SA Marking layout

RX8900 SA / CE

9.2.RX8900CE

9.2.1 External Dimensions

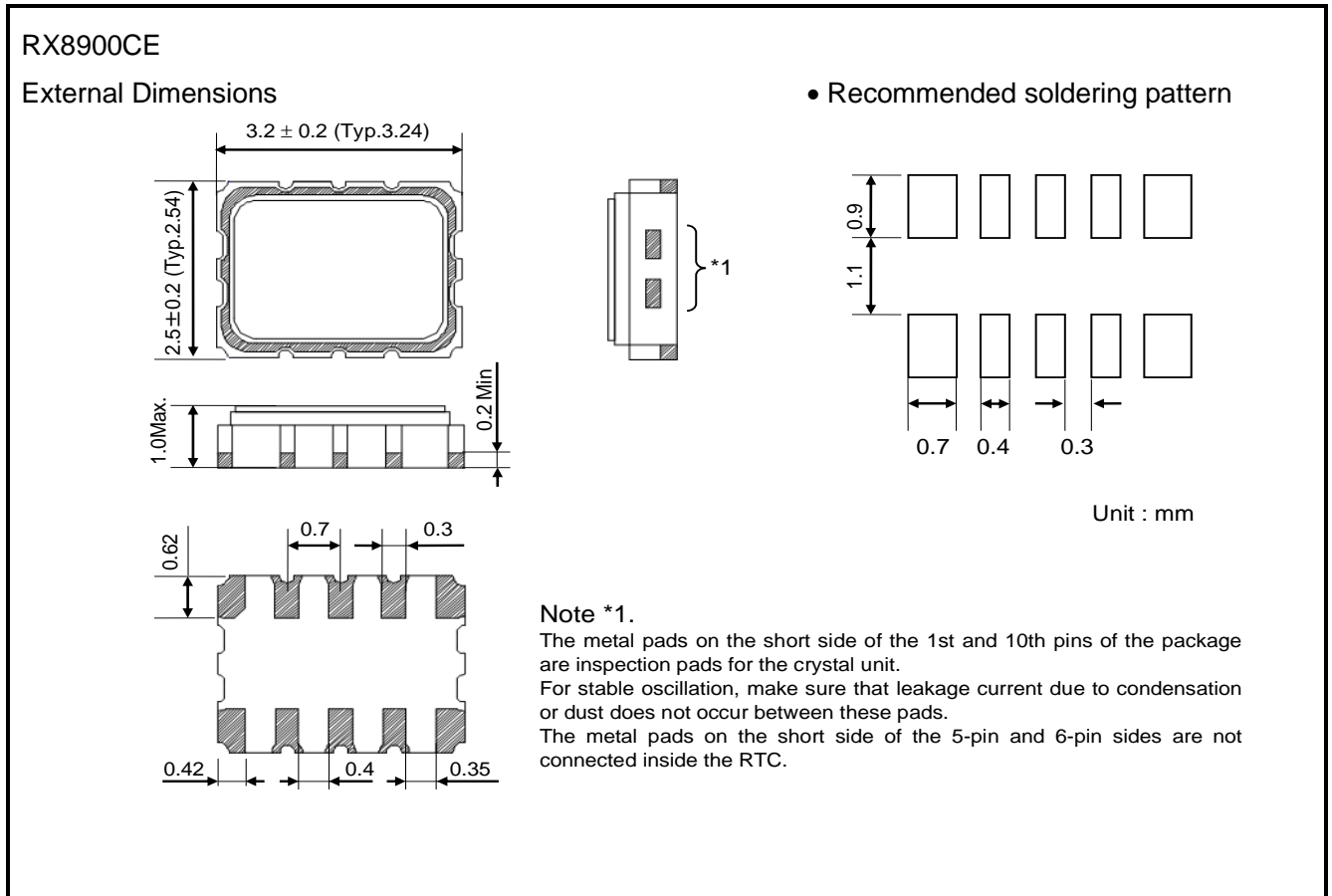

Figure 48 RX8900CE package

9.2.2. Marking layout

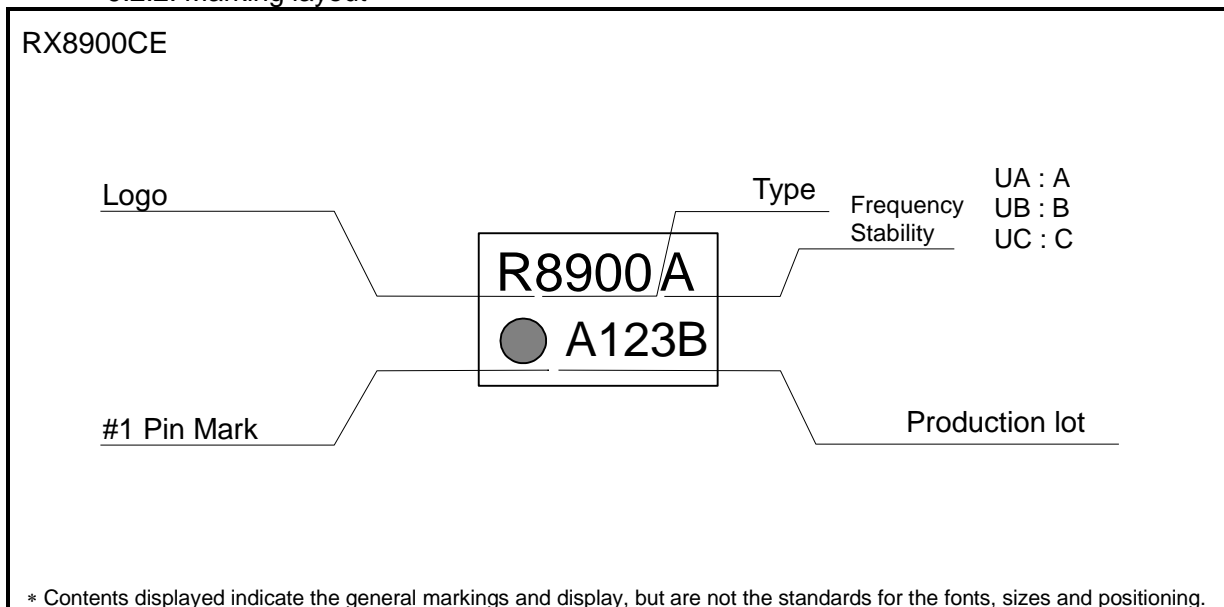

Figure 49 RX8900CE Marking layout

10 Application Notes

1) Notes on handling

This module uses a C-MOS IC to realize low power consumption. Carefully note the following cautions when handling.

(1) Static electricity

While this module has built-in circuitry designed to protect it against electrostatic discharge, the chip could still be damaged by a large discharge of static electricity. Containers used for packing and transport should be constructed of conductive materials. In addition, only soldering irons, measurement circuits, and other such devices which do not leak high voltage should be used with this module, which should also be grounded when such devices are being used.

(2) Noise

If a signal with excessive external noise is applied to the power supply or input pins, the device may malfunction or "latch up." In order to ensure stable operation, connect a filter capacitor (preferably ceramic) of greater than $0.1 \mu\text{F}$ as close as possible to the power supply pins (between VDD and GNDs). Also, avoid placing any device that generates high level of electronic noise near this module.

* Do not layout signal lines to the shaded area in the figure shown in Fig. 1 and, if possible, embed this area in a GND land.

(3) Voltage levels of input pins

When the mid-voltage (near to 50% of VDD) is applied to input-pins, it may occur the current increase, decrease of the margin of noise, and invites a error of functions. should apply near voltage of VDD or GND.

(4) Handling of unused pins

Since the input impedance of the input pins is extremely high, operating the device with these pins in the open circuit state can lead to unstable voltage level and malfunctions due to noise. Therefore, please apply the voltage level to near of VDD or GND.

(5) Installation of charged battery.

When a charged backup battery is installed by soldering, battery connection terminal of RTC should connect to GND, beforehand.

2) Notes on packaging

(1) Soldering heat resistance.

If the temperature within the package exceeds $+260 \text{ }^\circ\text{C}$, the characteristics of the crystal oscillator will be degraded and it may be damaged. The reflow conditions within our reflow profile is recommended. Therefore, always check the mounting temperature and time before mounting this device. Also, check again if the mounting conditions are later changed.

* See Fig. 2 profile for our evaluation of Soldering heat resistance for reference.

(2) Mounting equipment

While this module can be used with general-purpose mounting equipment, the internal crystal oscillator may be damaged in some circumstances, depending on the equipment and conditions. Therefore, be sure to check this. In addition, if the mounting conditions are later changed, the same check should be performed again.

(3) Ultrasonic cleaning

Depending on the usage conditions, there is a possibility that the crystal oscillator will be damaged by resonance during ultrasonic cleaning. Since the conditions under which ultrasonic cleaning is carried out (the type of cleaner, power level, time, state of the inside of the cleaning vessel, etc.) vary widely, this device is not warranted against damage during ultrasonic cleaning.

(4) Mounting orientation

This device can be damaged if it is mounted in the wrong orientation. Always confirm the orientation of the device before mounting.

(5) Leakage between pins

Leakage between pins may occur if the power is turned on while the device has condensation or dirt on it. Make sure the device is dry and clean before supplying power to it.

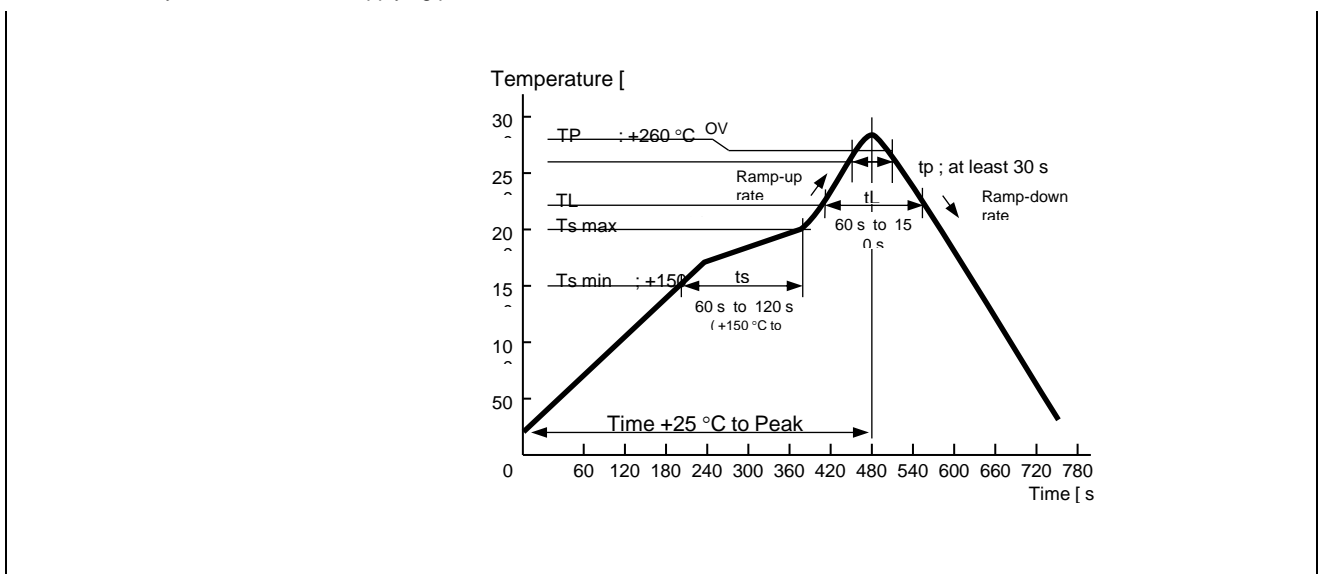

Figure 50 Reference profile

11 Tables

Table 1 Pin Description	7
Table 2. Absolute Maximum Rating	8
Table 3. Recommended Operating Conditions	8
Table 4. Frequency Characteristics	9
Table 5 DC characteristics	10
Table 6 AC Characteristics	11
Table 7 Basic Time and Calendar Registers.....	12
Table 8 Temperature Data, Backup power supply control register	14
Table 9 Register Quick Reference.....	14
Table 10. Clock Counter Registers	15
Table 11 Second Counter Register.....	15
Table 12 Minute Counter Register	15
Table 13 Hour Counter Register	15
Table 14. Calendar counter Register	16
Table 15. Week Counter Register.....	16
Table 16. Date Counter Registers.....	16
Table 17 Day Counter Register	17
Table 18. Date update pattern	17
Table 19. Month counter Register.....	17
Table 20 Year Counter Register	17
Table 21 Alarm Registers	17
Table 22 Fixed-cycle timer control registers	17
Table 23 Extension Register	18
Table 24 TEST bit	18
Table 25 USEL bit.....	18
Table 26 FSEL bits	18
Table 27 TSEL bits	19
Table 28 Flag Register.....	19
Table 29 VLF bit.....	19
Table 30 VDET bit.....	20
Table 31 Control Register	20
Table 32 CSEL bits	20
Table 33 UIE bit.....	21
Table 34 TIE bit.....	21
Table 35 AIE bit	21
Table 36 Temperature Data Register.....	22
Table 37 Backup power supply control register	22
Table 38 Related registers for function of time update interrupts.....	25
Table 39 TSEL bits	25
Table 40 Timer Counter Registers.....	26
Table 41 TE bit	26
Table 42 TF bit.....	26
Table 43 TIE bit.....	26
Table 44 Fixed-cycle timer interrupt interval	27
Table 45 Related registers for time update interrupt functions.....	29
Table 46 USEL bit.....	29
Table 47 UF bit	29
Table 48 UIE bit	30
Table 49 Alarm Related Registers	31
Table 50 WADA bit	32
Table 51 Alarm Registers	32
Table 52 AF bit	32
Table 53 AIE bit	33
Table 54 Examples of alarm setting 1.....	33
Table 55 Examples of alarm setting 2.....	33
Table 56 Temperature compensation Register	34
Table 57 CSEL bits	34
Table 58 Battery Backup switchover related register.....	36
Table 59 Battery Backup switchover related register setting	36
Table 60 Function status in Backup mode	36
Table 61 Diode (between VBAT from V _{DD}) reference characteristics	37
Table 62 The pros and cons of detection period setting.	39
Table 63 I ² C Bus Slave address	46
Table 64 Power supply, detection voltage	48

12 Figures

Figure 1 Block Diagram	6
Figure 2 Terminal connections.....	7
Figure 3 I ² C bus current consumption.....	9
Figure 4 Temperature compensation current consumption.....	10
Figure 5 I ² C Bus Timing Chart	11
Figure 6 32768Hz Divider, Counter, FOUT.....	16
Figure 7 Wakeup Timer Interrupt.....	23
Figure 8 Fixed-cycle Timer Interrupt Timing Chart.....	24
Figure 9 Fixed-cycle Timer Interrupt Block Diagram	25
Figure 10 Fixed-cycle Timer start-timing.....	27
Figure 11 An error of first count down.....	27
Figure 12 Time Update Interrupt.....	28
Figure 13 Time Update Interrupt Timing Chart.....	28
Figure 14 Time Update Interrupt Block Diagram.....	29
Figure 15 Alarm Interrupt.....	30
Figure 16 Alarm Interrupt Timing Chart.....	30
Figure 17 Alarm Interrupt Block Diagram.....	31
Figure 18 Battery Backup Switchover Block Diagram.....	35
Figure 19 IF vs VF reference characteristics.....	37
Figure 20 Mode flow of the backup power supply switchover function.....	38
Figure 21 Timing chart of the battery backup power switchover function.....	39
Figure 22 V _{DD} drop detection 1	40
Figure 23 . V _{DD} drop detection 2	40
Figure 24 Ex-1 Single power supply.....	41
Figure 25 Ex-2 Non- rechargeable battery. ex. CR2032, AAA.....	41
Figure 26 Ex-3 Rechargeable battery. EDLC, etc.....	41
Figure 27 Ex-4 For using high value protection resistor.....	41
Figure 28 Note of diode VF.....	42
Figure 29 Ex-5 Diode OR circuit.....	42
Figure 30 I ² C bus connection.....	43
Figure 31 I ² C bus START, RESRART timing.....	44
Figure 32 I ² C bus START STOP condition.....	44
Figure 33 I ² C bus data transfer	45
Figure 34 I ² C bus data acknowledge response.....	45
Figure 35 Address specification write sequence	46
Figure 36 Address specification read sequence	46
Figure 37. Read sequence when address is not specified.....	47
Figure 38. Backup and Recovery sequence	47
Figure 39 Oscillation starting sequence.....	48
Figure 40 An example of the initialization	49
Figure 41 Method of initialization after starting of internal oscillation.....	50
Figure 42 The setting of the clock and calendar	51
Figure 43 The reading of the clock and calendar	51
Figure 44 Connection example with Typical Microcontroller	52
Figure 45 Connection RTC used as a 32.768 kHz TCXO.....	52
Figure 46 RX8900SA package	53
Figure 47 RX8900SA Marking layout.....	53
Figure 48 RX8900CE package	54
Figure 49 RX8900CE Marking layout.....	54
Figure 50 Reference profile.....	55

Application Manual

Real Time Clock Module

RX8900 SA/CE

Contacts

America

Epson America, Inc.

Headquarter

3131 Katella Avenue Los Alamitos, CA 90720 USA

www.epson.com/microdevices

San Jose Office

214 Devcon Drive, San Jose, CA 95112 USA

Europe

Epson Europe Electronics GmbH

Headquarter

Riesstrasse 15, 80992 Munich, Germany

www.epson-electronics.de

Asia

Epson (China) Co., Ltd.

Headquarter

4F, Tower 1 of China Central Place, 81 Jianguo Street, Chaoyang District, Beijing, 100025 China

www.epson.com.cn/ed/

Shanghai Branch

High-Tech Building 900, Yishan Road, Shanghai, 200233 China

Shenzhen Branch

Room.603/604, 6 Floor, Tower 7, One Shenzhen Bay, No.3008 Center Rd, Shenzhen, 518054 China

Epson Hong Kong Ltd.

Unit 715-723 7/F Trade Square, 681 Cheung Sha Wan Road, Kowloon,

Hong Kong

www.epson.com.hk

Epson Taiwan Technology & Trading Ltd.

15F, No.100, Songren Rd., Sinyi Dist., Taipei City, 11073 Taiwan

www.epson.com.tw/ElectronicComponent

Epson Singapore Pte., Ltd.

Electronic Devices Sales Division Alexandra Technopark Block B, #04-01/04 438B Alexandra Rd, Singapore 119968

www.epson.com.sg/electronic-devices

Epson Korea Co.,Ltd

10F Posco Tower Yeoksam, Teheranro 134 Gangnam-gu, Seoul, 06235, Korea

www.epson.co.kr

Electronic devices information on WWW server

www5.epsondevice.com/en/