

HIGH-STABILITY HIGH-FREQUENCY OSCILLATOR

HG-1012JA / 2012JA

Product number (please refer to page 3)

Q3511JA0xxxxx00
Q3512JA0xxxxx00

- Cylindrical AT crystal unit built-in, thus assuring high reliability.
- Excellent heat resistance.
- Low current consumption.
- Available for lead (Pb)-free soldering.
- Available for lead (Pb)-free terminal.

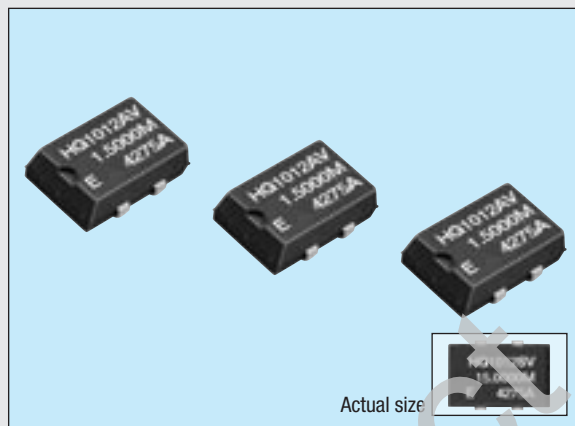

Specifications (characteristics)

Item	Symbol	Specifications		Remarks
		HG-1012JA	HG-2012JA	
Output frequency range	f _o	1.5000 MHz to 28.63636 MHz		V _{DD} = 4.75 V to 5.25 V
Power source voltage	Max. supply voltage	V _{DD} -GND		-0.5 V to +7.0 V
	Operating voltage	V _{DD}		5.0 V ±0.25 V
Temperature range	Storage temperature	T _{STG}		-55 °C to +125 °C
	Operating temperature	T _{OPR}		-40 °C to +85 °C
Frequency stability	Δf/f _o	AV: ±20 x 10 ⁻⁶ , BV: ±25 x 10 ⁻⁶	SV: ±15 x 10 ⁻⁶ , AV: ±20 x 10 ⁻⁶	T _a = -20 °C to +70 °C
		BX: ±25 x 10 ⁻⁶ , CX: ±30 x 10 ⁻⁶	BX: ±25 x 10 ⁻⁶	T _a = -40 °C to +85 °C
Current consumption	I _{OP}	10 mA Max.		No load condition
Duty	t _w / t	40 % to 60 %		1/2 V _{DD} level
High output voltage	V _{OH}	V _{DD} - 0.4 V Min.		I _{OH} = -0.8 mA
Low output voltage	V _{OL}	0.4 V Max.		I _{OL} = 3.2 mA
Output load condition	C _L	15 pF		
Output rise time	t _r	8 ns Max.		20 % → 80 % V _{DD} level
Output fall time	t _f	8 ns Max.		80 % → 20 % V _{DD} level
Oscillation start up time	t _{OSC}	4 ms Max.		Time at 4.75 V to be 0 s
Aging	f _a	±5 x 10 ⁻⁹ / year Max.	±2 x 10 ⁻⁶ / year Max.	T _a = +25 °C, first year
Shock resistance	S.R.	±10 x 10 ⁻⁶ Max.	±2 x 10 ⁻⁶ Max.	Three drops on a hard board from 750 mm or excitation test with 29400 m/s ² x 0.3 ms x 1/2sine wave in 3 directions

External dimensions

(Unit: mm)

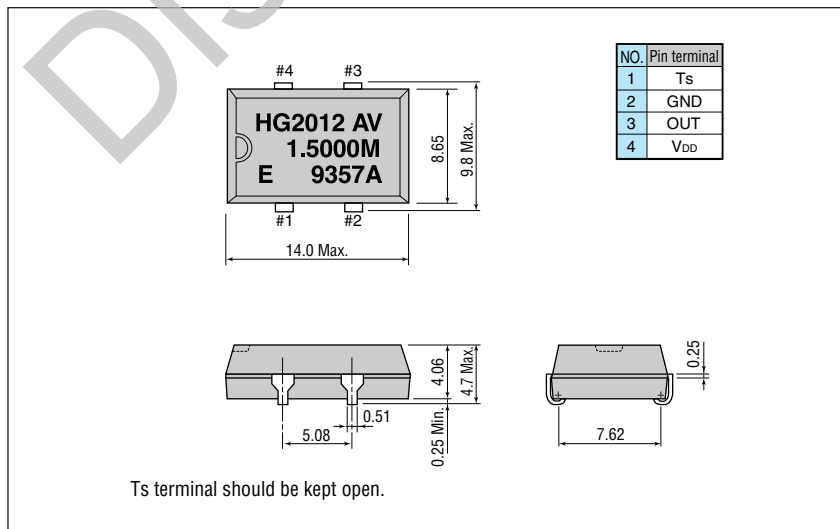

Recommended soldering pattern

(Unit: mm)

