

SERIAL-INTERFACE REAL TIME CLOCK MODULE

RTC-4513

- Built-in crystal unit allows adjustment-free efficient operation.
- Using a serial interface, controllable only three signal lines.
- Automatic leap year correction.
- 30 second adjustment, available.
- Wide operating voltage from 2.7 V to 5.5 V.

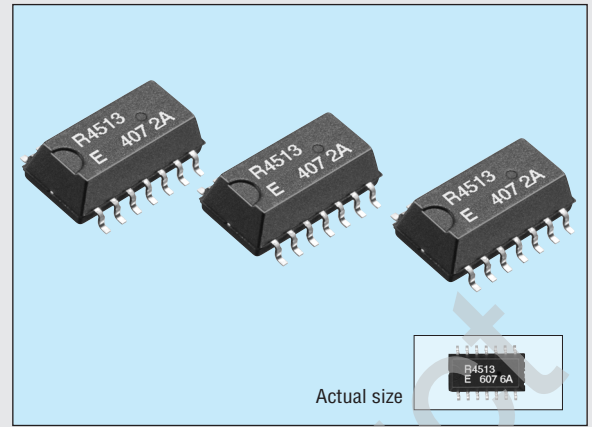

Specifications (characteristics)

Absolute Max. rating

Item	Symbol	Condition	Min.	Max.	Unit
Power source voltage	V _{DD}	V _{DD} -GND	-0.3	7.0	V
Input voltage	V _{IN}			V _{DD} +0.3	
Output voltage	V _{OUT}				
Storage temperature	T _{STG}		-55	+125	°C

Operating range

Item	Symbol	Condition	Min.	Typ.	Max.	Unit
Operating voltage	V _{DD}		2.7	5.0	5.5	V
Date holding voltage	V _{CLK}		2.0			
Operating temperature	T _{OPR}		-40		+85	°C

Frequency characteristics

Item	Symbol	Condition	Range	Unit
Frequency tolerance	Δf/f ₀	T _a =+25 °C, V _{DD} =3 V	0±25	x 10 ⁻⁶
Frequency temperature characteristics	T _{OP}	-10 °C to +70 °C	+10/-120	
f-V characteristics	f _v	T _a =+25 °C, V _{DD} =2.0 to 5.5 V	±5	x 10 ⁻⁶ /V
Aging	f _a	First year T _a =+25 °C, V _{DD} =3 V		x 10 ⁶ /year

DC characteristics

Item	Symbol	Condition	Min.	Typ.	Max.	Unit
"H" input voltage	V _{IH}	—	0.8V _{DD}			V
"L" input voltage	V _{IL}	—			0.2V _{DD}	
Input leak current 1	I _{IL1}	V _{IN} =V _{DD} /GND (CE,CLK)			1/-1	μA
Input leak current 2	I _{IL2}	V _{IN} =V _{DD} /GND (DATA)			10/-10	
"L" output voltage 1	V _{OL1}	I _o =1 mA (DATA)			0.2V _{DD}	V
"H" output voltage	V _{OH}	I _o =-400 μA (DATA)	0.8V _{DD}			
"L" output voltage 2	V _{OL2}	I _o =1 mA (STD.P)			0.2V _{DD}	V
Off leak current	I _{OFFLK}	V ₀ =V _{DD} (STD.P)			10.0	
Current consumption 1	I _{DD1}	V _{DD} =5 V, V _{IN} (CE) =0 V		10.0	20.0	μA
Current consumption 2	I _{DD2}	V _{DD} =3 V, V _{IN} (CE) =0 V		2.5	5.0	
Current consumption 3	I _{DD3}	V _{DD} =2 V, V _{IN} (CE) =0 V		1.0	2.0	

Terminal connection

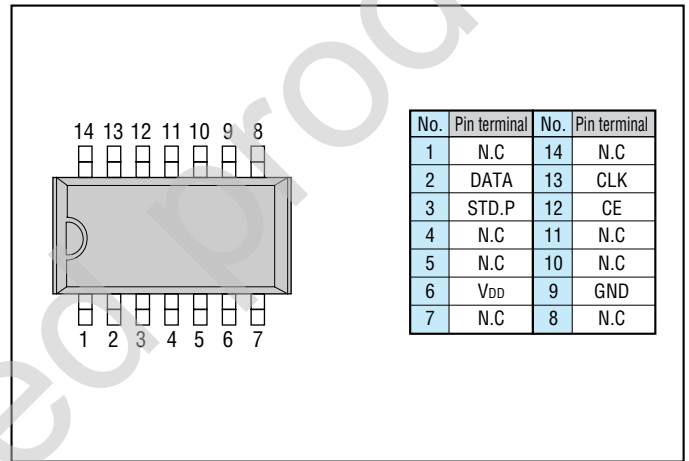

External dimensions

(Unit: mm)

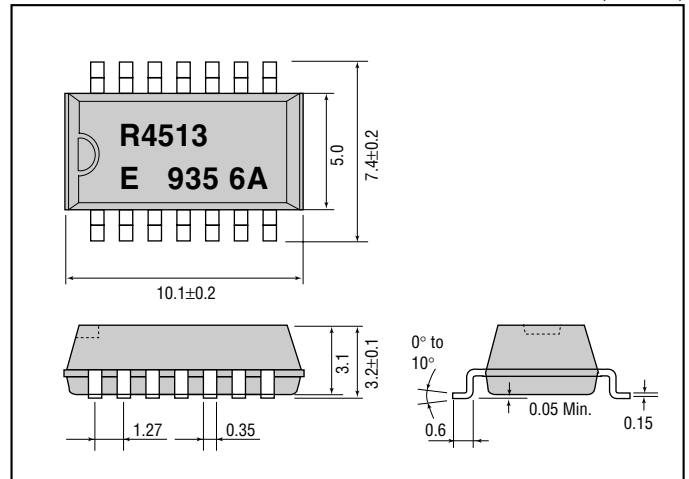

Register table

	Address				Register symbol	D ₃ (MSB)	D ₂	D ₁	D ₀ (LSB)		Register name
	A ₃	A ₂	A ₁	A ₀							
0	0	0	0	0	S ₁	s8	s4	s2	s1	0 to 9	1-second digit register
1	0	0	0	1	S ₁₀	f0	s40	s20	s10	0 to 5	10-second digit register
2	0	0	1	0	MI ₁	mi8	mi3	mi2	mi1	0 to 9	1-minute digit register
3	0	0	1	1	MI ₁₀	fr	mi40	mi20	mi10	0 to 5	10-minute digit register
4	0	1	0	0	H ₁	h8	h4	h2	h1	0 to 9	1-hour digit register
5	0	1	0	1	H ₁₀	fr	pm/am	h20	h10	0 to 1,2	10-hour digit register
6	0	1	1	0	D ₁	d8	d4	d2	d1	0 to 9	1-day digit register
7	0	1	1	1	D ₁₀	fr	*	d20	d10	0 to 3	10-day digit register
8	1	0	0	0	MO ₁	mo8	mo4	mo2	mo1	0 to 9	1-month digit register
9	1	0	0	1	MO ₁₀	fr	*		mo10	0 to 1	10-month digit register
A	1	0	1	0	Y ₁	y8	y4	y2	y1	0 to 9	1-year digit register
B	1	0	1	1	Y ₁₀	y80	y40	y20	y10		10-year digit register
C	1	1	0	0	W	fr	w4	w2	w1	0 to 6	day of the week register
D	1	1	0	1	CD	30ADJ	IRQ-F	CAL/HW	HOLD	—	Control register D
E	1	1	1	0	CE	t1	t0	INT/STND	MASK	—	Control register E
F	1	1	1	1	CF	TEST	24/12	STOP	RESET	—	Control register F

Switching characteristics

Item	Symbol	Condition	Min.	Max.	Unit	
CLK "H" time	t _{WH}	—	300	—	ns	
CLK "L" time	t _{WL}					
CE setup time	t _{CS}					
CE hold time	t _{CH}					
CE recovery time	t _{CR}					
CLK setup time	t _{CKS}					
CLK hold time	t _{CKH}					
Write data setup time	t _{DS}					50
Write data hold time	t _{DH}					
Read data delay time	t _{RD}					CL=50 pF
Read data disable delay time	t _{RZ}	—	—	100		
CLK rise time/fall time	t _{RF}	—	—	20		

Block diagram

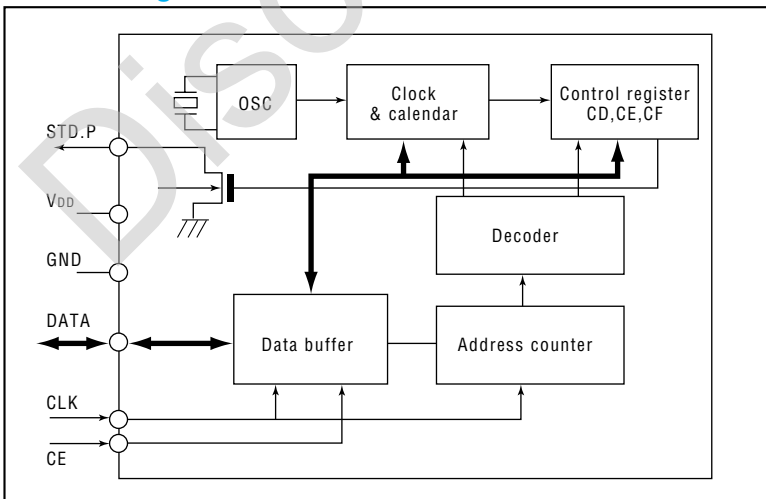

Timing chart

