

SERIAL INTERFACE RTC WITH AN ALARM TIMER

RTC-4573SB

- Built-in crystal unit allows adjustment-free efficient operation.
- 2.0 mm thickness featuring high-density mounting.
- Using a serial interface, controllable only three signal lines.
- Alarm interruption of sec. to month and day of week possible.
- Interval timer interrupt function that can be set with an interval ranging from 1/4096 of a second to 255 minutes.
- Automatic leap year correction.
- Similar mounting method to that used for universal type SMD IC.
- Low current consumption. (0.5 μ A/3 V Typ.)

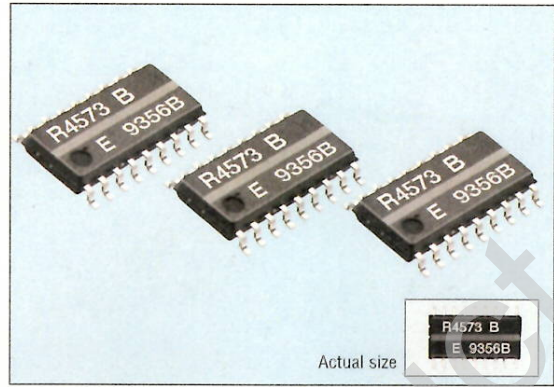

Specifications (characteristics)

Absolute Max. rating

Item	Symbol	Condition	Min.	Max.	Unit
Supply voltage	V_{DD}	V_{DD} -GND	-0.3	+7.0	V
Input voltage	V_{IN}	Input Pin		$V_{DD}+0.3$ V	
Output voltage	V_{OUT1}	TIRQ, AIRQ		+8.0	
	V_{OUT2}	FOUT, DATA	$V_{DD}+0.3$ V		
Storage temperature	T_{STG}	Stored without tape & reel	-55	+125	$^{\circ}$ C
Soldering conditions	T_{SOL}		Twice at under +260 $^{\circ}$ C within 10 s or under +230 $^{\circ}$ C within 3 min.		

Operating range

Item	Symbol	Condition	Min.	Max.	Unit
Operating voltage	V_{DD}	—	1.6	5.5	V
Operating temperature	T_{OPR}	—	-40	+85	$^{\circ}$ C

Frequency characteristics

Item	Symbol	Condition	Range	Unit
Frequency tolerance	$\Delta f/f_0$	$T_a=+25$ $^{\circ}$ C, $V_{DD}=3$ V	5 ± 23	$\times 10^{-6}$
Frequency temperature characteristics	T_{CP}	$T_a=-10$ $^{\circ}$ C to +70 $^{\circ}$ C, Reference at +25 $^{\circ}$ C	+10 -120	
Frequency voltage characteristics	f_v	$T_a=+25$ $^{\circ}$ C, $V_{DD}=1.6$ to 5.5 V	± 2	$\times 10^{-6}/V$
Oscillation start up time	t_{STA}	$T_a=+25$ $^{\circ}$ C, $V_{DD}=1.6$ V	3	s
Aging	f_a	$T_a=+25$ $^{\circ}$ C, $V_{DD}=3$ V, first year	± 5	$\times 10^4/\text{year}$

DC characteristics

($V_{DD}=1.6$ to 5.5 V, $T_a=-40$ to +85 $^{\circ}$ C)

Item	Symbol	Condition	Min.	Typ.	Max.	Unit
Input voltage	V_{IH}	CE_0, CE_1	0.8 V_{DD}	—	V_{DD}	V
	V_{IL}	CLK, DATA pins	0	—	0.2 V_{DD}	
Input leakage current	I_{LK}	$V_I=GND$ or V_{DD} DATA, CLK pins	-0.5	—	0.5	μ A
Pulldown R1	R_{DWN1}	$V_{DD}=5$ V	75	150	300	$k\Omega$
Pulldown R2	R_{DWN2}	$V_{DD}=3$ V	150	300	600	
Output voltage 1	V_{OH1}	$V_{DD}=5$ V	4.5	—	5.0	V
	V_{OH2}	$V_{DD}=3$ V	2.0	—	3.0	
	V_{OL1}	$V_{DD}=5$ V	—	—	GND+0.5	
	V_{OL2}	$V_{DD}=3$ V	—	—	GND+0.8	
Output voltage 2	V_{OL3}	$V_{DD}=5$ V	—	—	GND+0.25	V
	V_{OL4}	$V_{DD}=3$ V	—	—	GND+0.4	
Leakage current	I_{OZ}	$V_O=GND$ or V_{DD} , DATA, AIRQ, TIRQ pins	-0.5	—	0.5	μ A
Standby current 1	I_{DD1}	$V_{DD}=5$ V	—	1.0	2.0	μ A
Standby current 2	I_{DD2}	$V_{DD}=3$ V	—	0.5	1.0	

Terminal connection

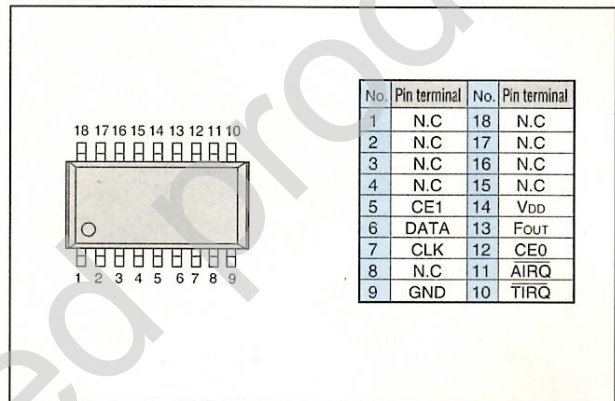

External dimensions

(Unit: mm)

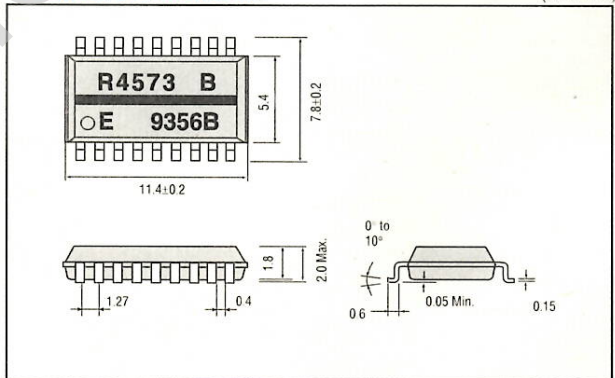

Register table

Address	Register symbol	bit 7	bit 6	bit 5	bit 4	bit 3	bit 2	bit 1	bit 0
0	Sec	fos	S40	S20	S10	S8	S4	S2	S1
1	Min	fr	Min40	Min20	Min10	Min8	Min4	Min2	Min1
2	Hour	fr	*	Hour20	Hour10	Hour8	Hour4	Hour2	Hour1
3	Week	fr	W7	W6	W5	W4	W3	W2	W1
4	Day	fr	*	Day20	Day10	Day8	Day4	Day2	Day1
5	Month	fr	*	*	Month10	Month8	Month4	Month2	Month1
6	Year	Year80	Year40	Year20	Year10	Year8	Year4	Year2	Year1
7	Minutes Alarm	AE	A-Min40	A-Min20	A-Min10	A-Min8	A-Min4	A-Min2	A-Min1
8	Hours Alarm	AE	*	A-Hr20	A-Hr10	A-Hr8	A-Hr4	A-Hr2	A-Hr1
9	Week Alarm	AE	A-W7	A-W6	A-W5	A-W4	A-W3	A-W2	A-W1
A	Day Alarm	AE	*	A-Day20	A-Day10	A-Day8	A-Day4	A-Day2	A-Day1
B	F _{OUT} control	FE	*	FD ₄	FD ₃	*	FD ₂	FD ₁	FD ₀
C	Timer interrupt control	TE	*	TD ₁	TD ₀	*	*	*	*
D	Count Down Timer	Timer128	Timer64	Timer32	Timer16	Timer8	Timer4	Timer2	Timer1
E	Control 1	*	*	*	TI/TP	AF	TF	AIE	TIE
F	Control 2	*	TEST	STOP	RESET	HOLD	*	*	*

Switching characteristics

(GND=0 V, Ta=-40 °C to +85 °C)

Item	Symbol	V _{DD} =3.0 V±10 %		V _{DD} =5.0 V±10 %		Unit	
		Min.	Max.	Min.	Max.		
CLK clock cycle	t _{CLK}	1200		600		ns	
CLK H Pulse Width	t _{WH}			300			
CLK L Pulse Width	t _{WL}	600					
CE setup time	t _{CS}	300		150			
CE hold time	t _{CH}	400		200			
CE recovery time	t _{CR}	600		300			
CLK hold time	t _{CKH}						
Write data setup time	t _{DS}	100		50			
Write data hold time	t _{DH}						
Read data delay time	t _{RD}	0	400	0	200		
Read data disable delay time	t _{RZ}		200		100		
Rise and fall time	t _{RF}		40		20		
F _{OUT} duty ratio (32.768 kHz output)	Duty	35	65	40	60		%

Block diagram

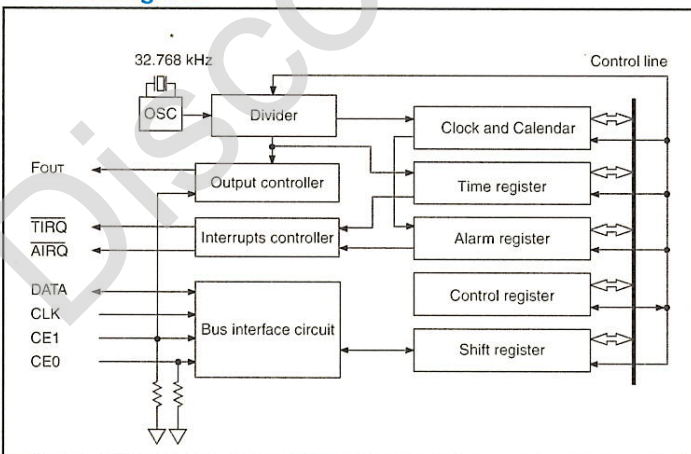

Timing chart

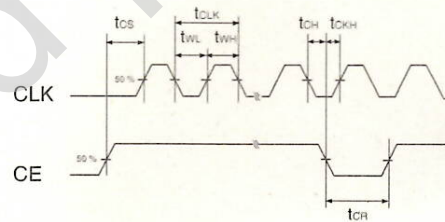

Write mode

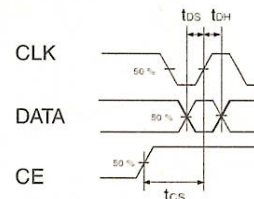

Read mode

