

8-bit REAL TIME CLOCK MODULE

RTC-65271

- Built-in crystal unit allows adjustment-free efficient operation.
- A builtin power supply switching circuit makes it possible to provide automatic power supply backup to both the RTC and extended RAM.
- The real-time clock block consists of:
 Indirect register: 1-byte Control register: 4-bytes
 Clock, alarm, calendar: 10-bytes User RAM: 50-bytes
- Extended RAM: 4k-bytes of builtin S-RAM
 Page register: 1-byte Configuration: 32-bytes x 128 pages
- The package is a 28-pin DIP IC with a battery holder that makes battery replacement possible.
- Batteries (BR1225) are available as an option. (Batteries are packed separately from the RTC.)

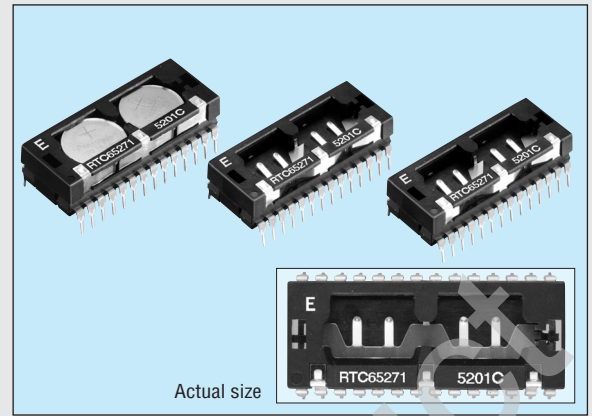

Actual size

Specifications (characteristics)

Batteries in this photograph are used only to show the inserted condition. This RTC is not supplied with the batteries inserted.

Absolute Max. rating

Item	Symbol	Condition	Min.	Max.	Unit
Supply voltage	V _{DD}	V _{DD} -GND	-0.3	+7.0	V
Input voltage	V _{IN}	Input Pin		V _{DD} +0.3	
Storage temperature	T _{STG}	*1	-40	+85	°C
Soldering condition	T _{SOL}	+260 °C or less, for 10 s or less; (package should be +150 °C or less)			

*1 Storage temperature as a discrete component.

Operating conditions

Item	Symbol	Condition	Min.	Typ.	Max.	Unit
Supply voltage	V _{DD}	—	4.75	5.0	5.5	V
Operating temperature	T _{OPR}	—	-10	—	+70	°C

Frequency characteristics

Item	Symbol	Condition	Max.	Unit
Frequency tolerance	Δf/f ₀	T _a =+25 °C, V _{DD} =5 V	5±20	x 10 ⁻⁶
Temperature characteristics	T _{OP}	T _a =-10 to +70 °C, V _{DD} =5 V *1	+10 -120	
Voltage characteristics	f _v	T _a =stable, V _{DD} =3 V *1	±5	x 10 ⁶ /V
Aging	f _a	T _a =+25 °C, V _{DD} =5 V, first year	±5	x 10 ⁶ /year

*1: The frequency deviation (0 x 10⁻⁶) at T_a=+25 °C for "top" or at V_{DD}=5 V for "fv" is used as the reference value.

DC characteristics

(V_{DD} = 5.0 V ± 10 %, T_a = -10 to +70 °C)

Item	Symbol	Condition	Min.	Typ.	Max.	Unit
Input voltage	V _{IH}	—	2.2	—	V _{DD} +0.3	V
	V _{IL}		-0.3		0.8	
Input leak current	I _I	RESET, RD, WR, RTC, XRAM, D ₀ to D ₇ , A ₀ to A ₅	—	—	±1	μA
Output voltage	V _{OH}	V _{DD} =5 V, I _{LOAD} =4 mA	2.4	—	—	V
	V _{OL}	V _{DD} =5 V, I _{LOAD} =4 mA	—	—	0.4	
Power supply current	I _{DD}	Output unloaded	—	—	15	mA
Current when using battery backup	I _{BAT}	T _a =+25 °C	—	0.5	1.0	μA
Input current	I _{STBY}	STBY=GND	—	—	2	

Note: For information on handling batteries, please independently refer to the pertinent regulations, as this product does not come equipped with batteries.

Terminal connection

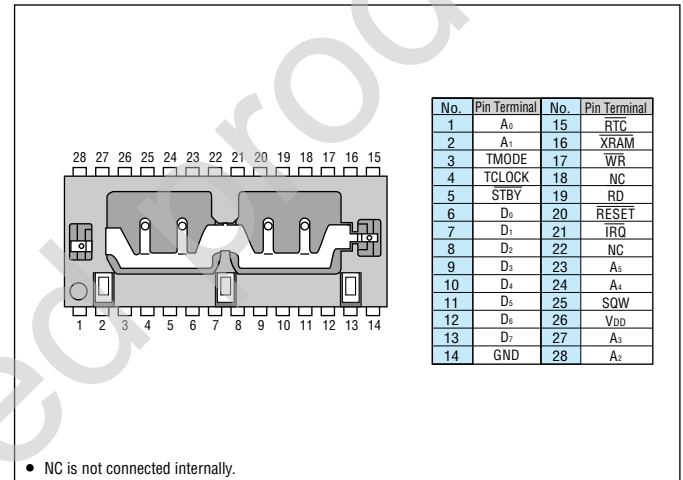

External dimensions

(Unit: mm)

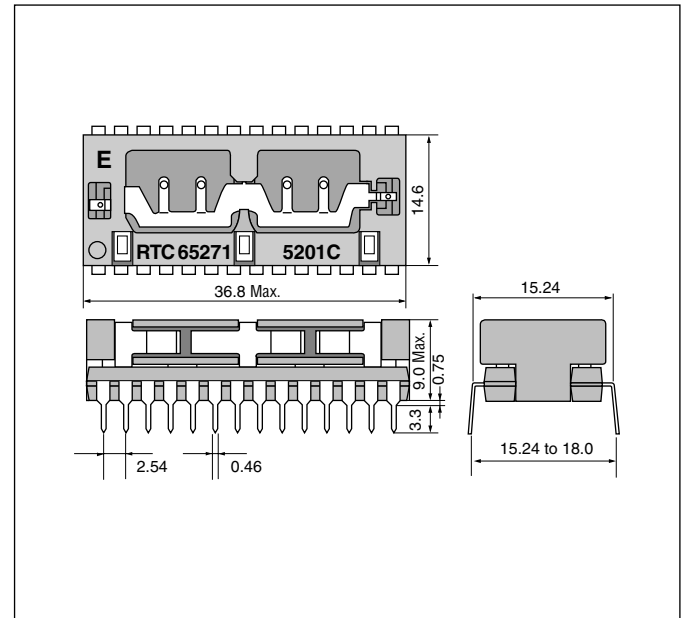

Address map

RTC address map

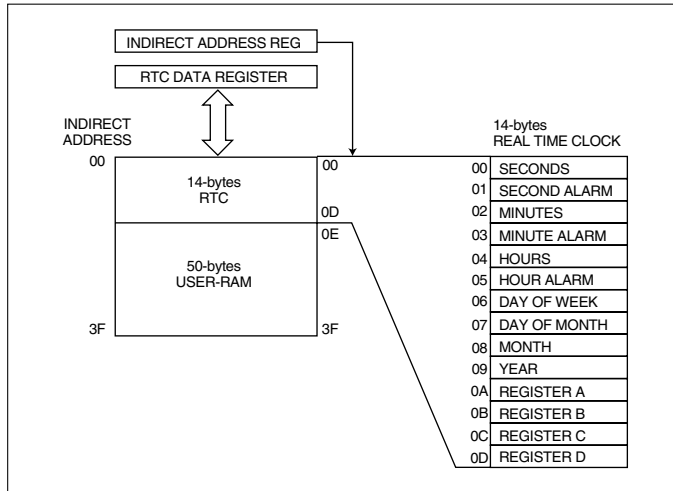

Extended RAM address map

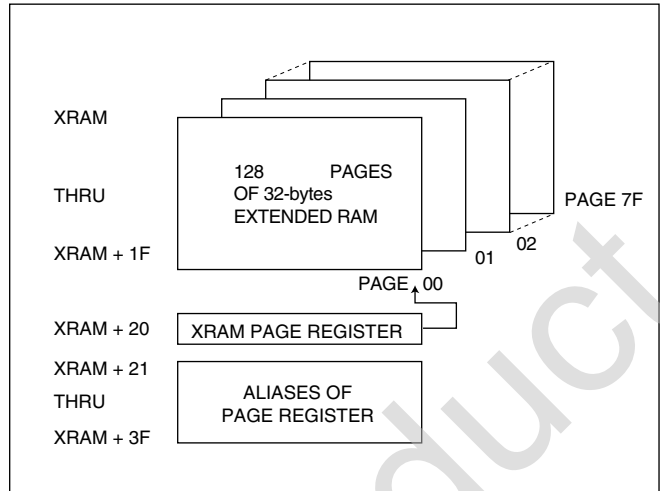

Switching characteristics (V_{DD} = 5 V ± 10 %, G_{ND} = 0 V, T_a = -10 to +70 °C)

Item	Symbol	Min.	Max.	Remarks
Cycle Time	t _{cy}	395	DC	ns
Pulse width $\overline{RD}/\overline{WR}="L"$ interval	t _{rwl}	325	—	
Signal rise / fall time CS, \overline{RD} , \overline{WR}	t _r , t _f	—	30	
Address holding time	t _{ah}	20	—	
Address setup before \overline{RD}	t _{ars}	50	—	
Address setup before \overline{WR}	t _{aws}	0	—	
Chip select setup time before \overline{RD}	t _{crs}	50	—	
Chip select setup time before \overline{WR}	t _{cws}	0	—	
Chip select hold time a after $\overline{RD}/\overline{WR}$	t _{ch}	20	—	
Read data holding time	t _{dhr}	10	100	
Write data holding time	t _{dhw}	0	—	
\overline{RD} Peripheral output data delay time	t _{odr}	20	240	
Peripheral write data setup time	t _{dsw}	200	—	

Timing chart

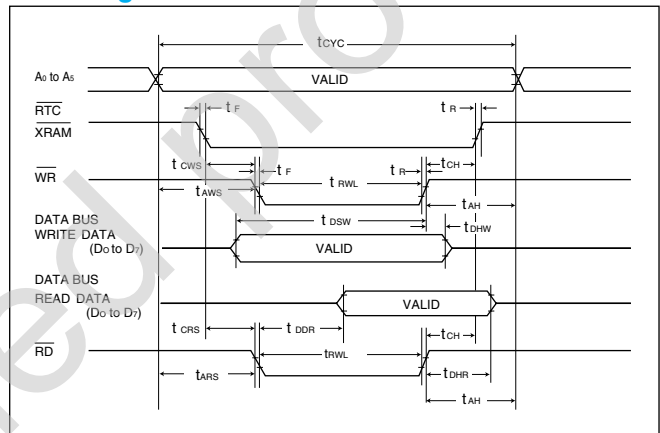

Block diagram

