

I²C-BUS COMPATIBLE REAL TIME CLOCK MODULE

RTC-8583/8593 series

- Built-in crystal unit. Adjustment free with 10 pF external capacitor.
- Small package (SOP 14-pin).
- Three mode operations: internal crystal oscillation, external 50 Hz clock and event counter.
- I²C-Bus interface compatible.
- Built-in 240 x 8 bit S-RAM available (RTC8583).
- Alarm and timer functions available.
- Wide operating voltage range 2.5 V to 6.0 V.
- Wide data hold voltage range 1.0 V to 6.0 V.
- Low current consumption (RTC8593, 1.0 μA typical).

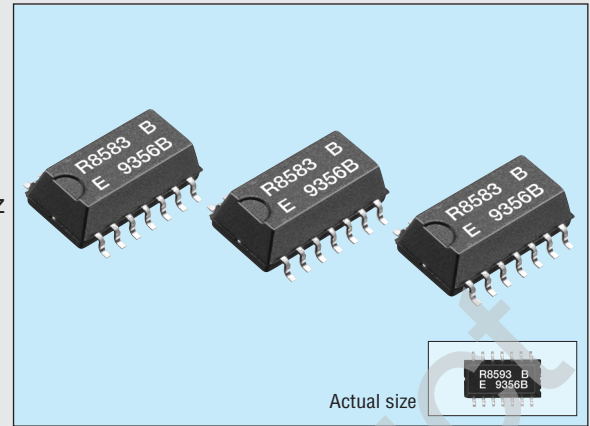

Specifications (characteristics)

Absolute Max. rating

Item	Symbol	Condition	Min.	Max.	Unit
Supply voltage	V _{DD}	V _{DD} -GND	-0.8	+7.0	V
Input voltage	V _{IN}			V _{DD} +0.8	
Input current	I _I			10	mA
Output current	I _O				
Storage temperature	T _{STG}		-55	+125	°C

Operating range

Item	Symbol	Condition	Min.	Max.	Unit
Operating voltage	V _{DD}		2.5	6.0	V
Data holding voltage	V _{CLK}		1.0		
Operating temperature	T _{OPR}		-30	+70	°C
External capacitor	C _G		10±5 %		pF

Frequency characteristics

Item	Symbol	Condition	Max.	Unit
Frequency tolerance	Δf/f ₀	T _a =+25 °C, V _{DD} =5 V	A: 5±20 B: 5±50	x 10 ⁻⁶
Frequency temperature characteristics	T _{OP}	T _a =-10 °C to +70 °C, V _{DD} =5 V	+10 -120	
Frequency voltage characteristics	f _V	T _a =+25 °C, V _{DD} =2.0 to 6.0 V	±3	
Oscillation start-up time	t _{OSC}	T _a =+25 °C, V _{DD} =5 V	3	s
Aging	f _A	T _a =+25 °C, V _{DD} =5 V first year	±5	x 10 ⁶ /year

DC characteristics

Item	Pin	Symbol	Condition	Min.	Typ.	Max.	Unit
"H" input voltage	SDA	V _{IH}	—	0.7V _{DD}		V _{DD} +0.8	V
"L" input voltage		V _{IL}		-0.8		0.3	
"L" output current		I _{OL}	V _{OL} =0.4 V	3			
Input leak current						1	μA
Leak current	A ₀ RESET OSC1	I _L	V _{IN} =V _{DD} or GND			250	nA
Output current	INT	I _{OL}	V _{OL} =0.4 V	1			mA
Leak current	INT SCL	I _L	V _{IN} =V _{DD} or GND			1	
Source current (access)		I _{DD0}	f _{SCL} =100 kHz			200	
Current Consumption (non access)	8583	1	I _{DD1} V _{DD} =5 V, f _{SCL} =0 Hz	10	50	μA	
		2	I _{DD2} V _{DD} =3 V, f _{SCL} =0 Hz	3.5	15		
		3	I _{DD3} V _{DD} =2 V, f _{SCL} =0 Hz	2.0	10		
	8593	1	I _{DD1} V _{DD} =5 V, f _{SCL} =0 Hz	3.0	15		
		2	I _{DD2} V _{DD} =3 V, f _{SCL} =0 Hz	1.2	10		
		3	I _{DD3} V _{DD} =2 V, f _{SCL} =0 Hz	1.0	8		

The I²C-Bus is a trademark of Philips Electronics N.V.

Terminal connection

RTC-8583/8593

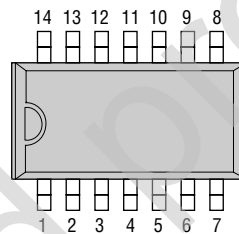

No.	8583	8593	8593SB
1	GND1	N.C	N.C
2	SCL	SCL	N.C
3	SDA	SDA	N.C
4	N.C	N.C	N.C
5	GND	GND	N.C
6	N.C	N.C	N.C
7	A0	RESET	N.C
8	OSC1	OSC1	RESET
9	N.C	N.C	GND
10	N.C	N.C	SDA
11	V _{DD}	V _{DD}	SCL
12	N.C	N.C	INT
13	N.C	N.C	V _{DD}
14	INT	INT	OSC1
15			N.C
16			N.C
17			N.C
18			N.C

RTC-8593SB

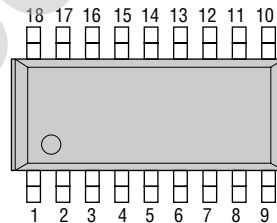

External dimensions

(Unit: mm)

RTC-8583/8593 (SOP 14-pin)

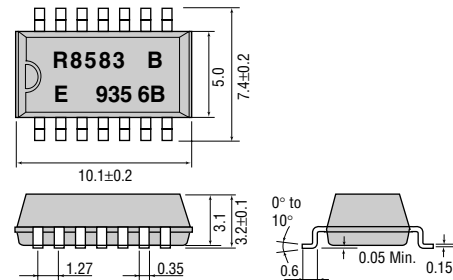

RTC-8593SB (SOP 18-pin)

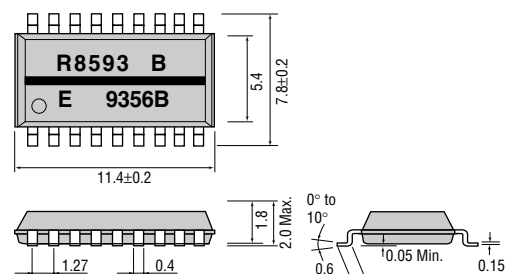

Register table

Address	Register name	count	bit 7	bit 6	bit 5	bit 4	bit 3	bit 2	bit 1	bit 0
00	CNT		STOP	HOLD	MODE1	MODE2	MASK	ALM	AF	TF
01	1/100SEC	0 to 99	8/10	4/10	2/10	1/10	8/100	4/100	2/100	1/100
02	SEC	0 to 59	10S8	10S4	10S2	10S1	S8	S4	S2	S1
03	MIN	0 to 59	10MIN8	10MIN4	10MIN2	10MIN1	MIN8	MIN4	MIN2	MIN1
04	HOUR	0 to 23	12/24	AM/PM	10HOUR2	10HOUR1	HOUR8	HOUR4	HOUR2	HOUR1
05	DAY	0 to 31	YEAR2	YEAR1	10DAY2	10DAY1	DAY8	DAY4	DAY2	DAY1
06	MONTH	0 to 12	W4	W2	W1	10MONTH1	MONTH8	MONTH4	MONTH2	MONTH1
07	TIMER	0 to 99	10TIMER8	10TIMER4	10TIMER2	10TIMER1	TIMER8	TIMER4	TIMER2	TIMER1
08	ALARM		AIE	TAIE	AS1	AS0	TIE	TCP2	TCP1	TCPO
09	A-1/100	0 to 99	A-8/10	A-4/10	A-2/10	A-1/10	A-8/100	A-4/100	A-2/100	A-1/100
0A	A-SEC	0 to 59	10A-SEC8	10A-SEC4	10A-SEC2	10A-SEC1	10A-SEC8	10A-SEC4	10A-SEC2	10A-SEC1
0B	A-MIN	0 to 59	10A-MIN8	10A-MIN4	10A-MIN2	10A-MIN1	10A-MIN8	10A-MIN4	10A-MIN2	10A-MIN1
0C	A-HR	0 to 23	A-12/24	A-AM/PM	10A-HR2	10A-HR1	A-HR8	A-HR4	A-HR2	A-HR1
0D	A-DAY	0 to 31	—		A-DAY2	A-DAY1	A-DAY8	A-DAY4	A-DAY2	A-DAY1
0E	A-MON	0 to 12	—			10A-MON1	10A-MON8	10A-MON4	10A-MON2	10A-MON1
0F	A-TIM	0 to 99	10A-TIM8	10A-TIM4	10A-TIM2	10A-TIM1	A-TIM8	A-TIM4	A-TIM2	A-TIM1
10 to FF		0 to FF	User's RAM (RTC-8583 is available)							

Switching characteristics

Item	Symbol	Min.	Max.	Unit
SCL clock frequency	f _{SCL}	—	100	kHz
Spike tolerance on bus	t _{sw}	—	100	ns
Bus free time	t _{BUF}	4.7	—	μs
Start condition set-up time	t _{SU} ; STA	4.0	—	μs
Hold time	t _{HD} ; STA	4.0	—	μs
SCL "L" time	t _{LOW}	4.7	—	μs
SCL "H" time	t _{HIGH}	4.0	—	μs
SCL, SDA rise time	t _{TLH}	—	1.0	ns
SCL, SDA fall time	t _{THL}	—	0.3	ns
Date set-up time	t _{SU} ; DAT	250	—	ns
Date hold time	t _{HD} ; DAT	0	—	ns
SCL low to data out valid	t _{VD} ; DAT	—	3.4	μs
Stop condition set-up time	t _{SU} ; STO	4.0	—	μs
Event counter frequency	f _i	—	1.0	MHz

Timing chart

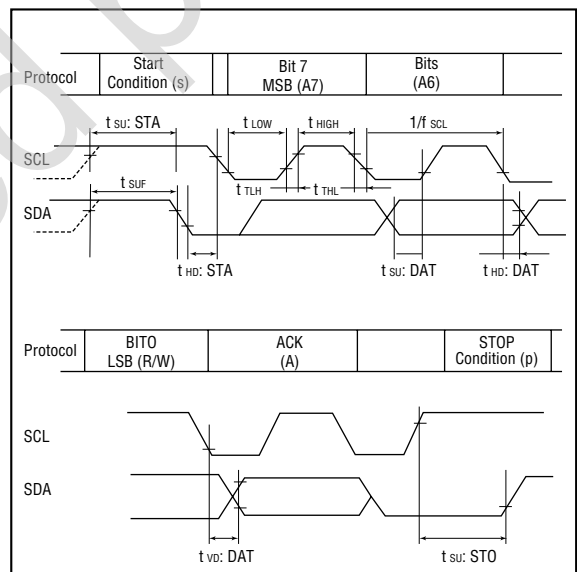

Block diagram

