

REAL TIME CLOCK MODULE (SPI-Bus)
 High-Stability Frequency with Built in Timestamp and Power Switching



Product Number
RX-4035SA B: X1B000192000100
RX-4035SA AC: X1B000192000200
RX-4035SA AA: X1B000192000300
RX-4035LC B: X1B000202000100
RX-4035LC AC: X1B000202000200
RX-4035LC AA: X1B000202000300

RX-4035SA / LC

- Built-in 32.768 kHz crystal unit : Frequency adjusted for high accuracy. ($\pm 5 \times 10^{-6} / T_a = +25^\circ\text{C}$)
- Interface Type : SPI-Bus (1MHz)
- Operating voltage range : 2.4 V to 5.5 V
- Timekeeping voltage range : 1.0 V to 5.5 V
- Low backup current : 350 nA (SA) 400 nA (LC) / 3 V (Typ.)
- Event detection and Time stamp : One-shot full timestamp and interrupt.
- Dual event detection ports : Each terminal has a de-bounce circuit.
- Auto power switching functions : When VDD deteriorates than 2.4V, internal source is switched to VBAT.



RX-4035SA



RX-4035LC

Block diagram

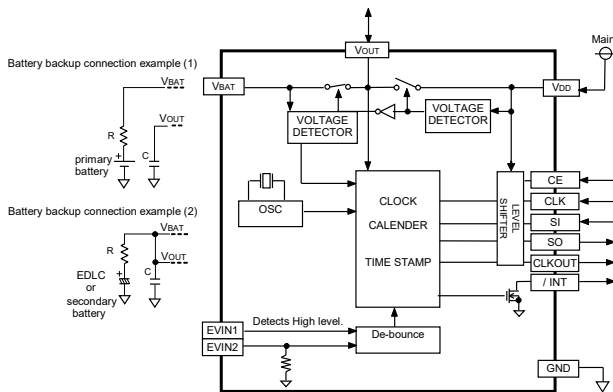

Overview

- **The event detection and Timestamp function**
 Dual event detection terminals.
 Selectable de-bounce time 35ms or 2s.
 Available event detection interrupt output.
- **Power switching functions.**
 - An external diode is unnecessary to have a reverse current prevention switch built-in in the VBAT side to connect a primary cell to.
 - When VDD is less than 2.4V, an internal source is switched to VBAT.
 - Note: When the supply from VBAT, SPI interface are disabled.
- **Alarm, Periodic interrupt, 32.768kHz clock output.**
 - Available monthly-alarm and weekly-alarm.
 - Interrupt period are selectable from 2Hz to Monthly.
 - CLKOUT outputs 32.768kHz clock powered by VDD.

Pin function

Signal Name	Input / Output	Function
VBAT	—	Power supply for backup.
Vout	Output	Switched power out. (maximum output current 20mA)
CE	Input	SPI chip enable.
CLK	Input	SPI serial clock.
SO	Output	SPI data out.
SI	Input	SPI data in.
GND	—	Ground
EVIN1	Input	Event detection input 1
EVIN2	Input	Event detection input 2
/ INT	Output	Interrupt out.
CLKOUT	Output	32.768kHz output. (CMOS. Can not inhibit.)
N.C.	—	Do not connect.
VDD	—	Main power supply.

Terminal connection / External dimensions

(Unit:mm)

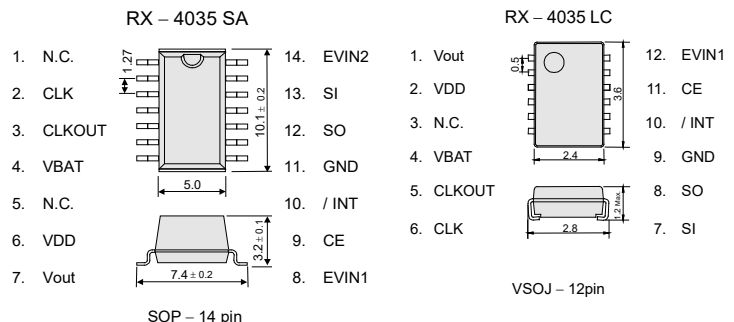

The metal case inside of the molding compound may be exposed on the top or bottom of this product. This purely cosmetic and does not have any effect on quality, reliability or electrical specs.

Prohibition of use of glue after a mount of a product
 An LC package product cannot use glue and resin coating. When such a processing is necessary, please examine a CE package product.

Specifications (characteristics)

* Refer to application manual for details.

Recommended Operating Conditions

Item	Symbol	Conditions	Min.	Typ.	Max.	Unit
Operating voltage	VACCESS	VDD	2.4	3.0	5.5	V
Time keeping voltage	VCLK	VBAT	1.0	3.0	5.5	V
Operating temperature	TOPR	—	-40	+25	+85	°C
Storage temperature	TSTG	—	-55	—	+125	°C

Frequency characteristics

Item	Symbol	Conditions	Rating	Unit
Frequency tolerance	$\Delta f / f$	Ta = +25°C VBAT = 3.0 V	B: 5 ± 23 *1) AA: 5 ± 5 *2) AC: 0 ± 5 *2)	$\times 10^{-6}$
Oscillation start-up time	tSTA	Ta = +25°C VDD = 3.0 V	1 Max.	s
Frequency / voltage characteristics	f / V	Ta = +25°C VDD = 2.4 V to 5.5 V	± 1 Max.	$\times 10^{-6}$

*1) Equivalent to ± 1 minute of monthly deviation (excluding offset.)
 *2) Equivalent to ± 13 seconds of monthly deviation (excluding offset.)

Current consumption characteristics

Ta = -40 °C to +85 °C

Item	Symbol	Conditions	Min.	Typ.	Max.	Unit
Current Consumption	IBAT	RX-4035SA VBAT = 3.0V, VDD = 0.0V CE = 0V, CLKOUT = open	-	350	1200	nA
		RX-4035LC VBAT = 3.0V, VDD = 0.0V CE = 0V, CLKOUT = open	-	400		
	IDD	VDD = 3.0V CE = 0V CLKOUT = open	-	1.40	2.50	μA

Power supply detection voltage

Ta = -40 °C to +85 °C

Item	Symbol	Conditions	Min.	Typ.	Max.	Unit
Voltage of low battery detection	VLow	-	1.10	1.25	1.40	V
Power switching voltage (VDD to VBAT)	VD2B	+25 °C	2.328	2.40	2.472	V

► Explanation of the mark that are using it for the catalog

	<p>► Pb free.</p>
	<p>► Complies with EU RoHS directive. *About the products without the Pb-free mark. Contains Pb in products exempted by EU RoHS directive. (Contains Pb in sealing glass, high melting temperature type solder or other.)</p>
	<p>► Designed for automotive general equipment.</p>
	<p>► Designed for automotive applications related to driving and safety.</p>

NOTICE : PLEASE READ CAREFULLY BELOW BEFORE THE USE OF THIS DOCUMENT

1. The content of this document is subject to change without notice. Before purchasing or using Epson products, please contact with sales representative of Seiko Epson Corporation ("Epson") for the latest information and be always sure to check the latest information published on Epson's official web sites and resources.
2. This document may not be copied, reproduced, or used for any other purposes, in whole or in part, without Epson's prior consent.
3. Information provided in this document including, but not limited to application circuits, programs and usage, is for reference purpose only. Epson makes no guarantees against any infringements or damages to any third parties' intellectual property rights or any other rights resulting from the information. This document does not grant you any licenses, any intellectual property rights or any other rights with respect to Epson products owned by Epson or any third parties.
4. Epson has prepared this document carefully to be accurate and dependable, but Epson does not guarantee that the information is always accurate and complete. Epson assumes no responsibility for any damages you incurred due to any misinformation in this document.
5. Epson products listed in this document and our associated technologies shall not be used in any equipment or systems that laws and regulations in Japan or any other countries prohibit to manufacture, use or sell. Furthermore, Epson products and our associated technologies shall not be used for the purposes of military weapons development (e.g. mass destruction weapons), military use, or any other military applications. If exporting Epson products or our associated technologies, please be sure to comply with the Foreign Exchange and Foreign Trade Control Act in Japan, Export Administration Regulations in the U.S.A (EAR) and other export-related laws and regulations in Japan and any other countries and to follow their required procedures.
6. Epson assumes no responsibility for any damages (whether direct or indirect) caused by or in relation with your non-compliance with the terms and conditions in this document or for any damages (whether direct or indirect) incurred by any third party that you give, transfer or assign Epson products.
7. For more details or other concerns about this document, please contact our sales representative.
8. Company names and product names listed in this document are trademarks or registered trademarks of their respective companies.

● Disclaimer

1. Epson products are designed for use in general electronic equipment applications that do not require extremely high reliability or safety.
2. Epson does not represent or warrant that its products will not cause a failure for any particular application, except for cases where the failure is a direct result caused by defects in materials and workmanship of this product.
 If a product fails due to defects in materials and workmanship, to the maximum extent permitted by law, we will, at our sole discretion, refund or replace the affected product.
3. When products for used directly or indirectly in certain devices or applications (ex. Nuclear power, aerospace, infrastructure facilities, medical equipment, etc.) which are connected to or affect safety of human life or property, Customer is solely responsible for determining if the products and respective specifications are suitable for the intended use in particular customer applications.
 Customer shall implement necessary and proper safety design and measures (including redundant design, malfunction prevention design, etc.) to ensure reliability and safety before using the products in/with customer's Equipment.
4. For the products designed for automotive applications, the products comply with AEC-Q100 or AEC-Q200.
 Products do not comply with ISO 26262 (Products are not categorized to ASIL A, B, C and D).
5. No dismantling, analysis, reverse engineering, modification, alteration, adaptation, reproduction, etc., of Epson products is allowed.
 Furthermore, any defects caused by this are not covered by the warranty.

©Seiko Epson Corporation 2025