

**REAL TIME CLOCK MODULE (SPI-Bus)
LOW BACKUP VOLTAGE**



Product Number
RX-4571LC : Q414571C2000100
RX-4571SA : Q41457152000100

RX-4571LC / SA

- Built in frequency adjusted 32.768 kHz crystal unit.
- Interface Type : 3-wire serial interface
- Operating voltage range : 1.6 V to 5.5 V
- The wide voltage for time keeping. : 1.0 V to 5.5 V / T_a = +25 °C
- Low backup current : 0.32 μA (Typ.) / 3 V
- 32.768 kHz frequency output function : C-MOS output With OE pin.
- Real-time clock function
 Clock/calendar function, auto leap year correction function, alarm and Timer interrupt function, etc.



Block diagram

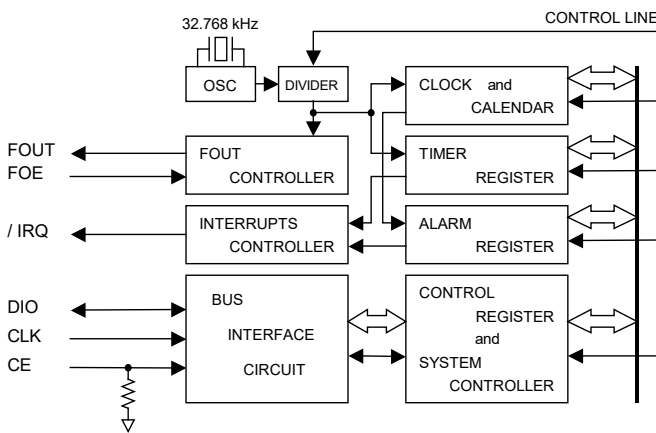

Overview

- **32.768 kHz frequency output function**
 - FOUT pin output (C-MOS output), CL=30 pF
- **Timer function**
 - Timer function which can be set up between 1/4096 second and 4095 minutes.
- **Alarm function**
 - Alarm function can be set to any combination of day, day of week, hour, or minute.

Pin Function

Signal Name	Input / Output	Function
CE	Input	The chip enabled input pin 0. (It has a built -in pull-down resistance)
CLK	Input	The shift clock input pin for serial data transfer.
DIO	Bi-directional	The data input / output pin for serial data transfer.
FOUT	Output	32.768 kHz clock output pin with the output control function. (C-MOS)
FOE	Input	FOE pin control the condition of FOUT with FSEL1-bit, FSEL0-bit, etc.
/ IRQ	Output	Interrupt output (N-ch open drain)
VDD	—	Connected to a positive power supply.
GND	—	Connected to a ground.

Terminal connection / External dimensions

(Unit:mm)

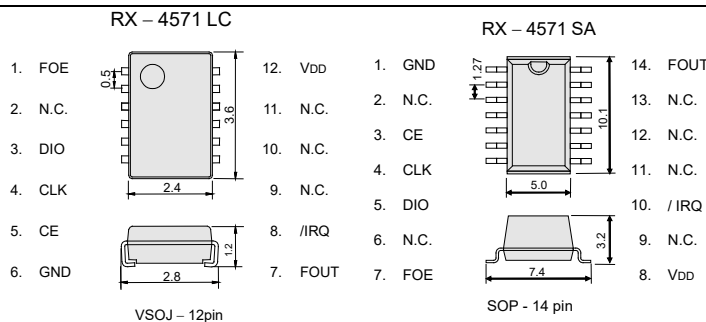

Prohibition of use of glue after a mount of a product
 An LC package product cannot use glue and resin coating.
 When such a processing is necessary, please examine a CE package product.

The metal case inside of the molding compound may be exposed on the top or bottom of this product.
 This purely cosmetic and does not have any effect on quality, reliability or electrical specs.

Specifications (characteristics)

* Refer to application manual for details.

Recommended Operating Conditions

Item	Symbol	Conditions	Min.	Typ.	Max.	Unit
Power voltage	VDD	—	1.6	3.0	5.5	V
Clock voltage	VCLK	T _a = +25 °C	1.0	3.0	5.5	V
		T _a = -40 to +85 °C	1.1	3.0	5.5	V
Operating temperature	TOPR	—	-40	+25	+85	°C

Frequency characteristics

Item	Symbol	Conditions	Rating	Unit
Frequency tolerance	Δf/f	T _a = +25 °C VDD = 3.0 V	B: 5 ± 23 *	× 10 ⁻⁶
Oscillation start-up time	t _{STA}	T _a = +25 °C VDD = 1.6 V	1 Max.	s

* Please ask for tighter tolerance. (Equivalent to ±1 minute of monthly deviation)

Current consumption characteristics

T_a = -40 °C to +85 °C

Symbol	Conditions	Min.	Typ.	Max.	Unit	
I _{BK}	CE = GND /IRQ = OFF	VDD = 5 V	-	0.40	1.00	μA
	FOUT ; output OFF (Hi - z)	VDD = 3 V	-	0.32	0.95	
I _{32k}	CE = GND /IRQ = OFF	VDD = 5 V	-	8.0	14.0	μA
	FOUT ; 32.768 kHz output ON CL = 30 pF	VDD = 3 V	-	5.0	8.5	

► Explanation of the mark that are using it for the catalog

	<p>► Pb free.</p>
	<p>► Complies with EU RoHS directive. *About the products without the Pb-free mark. Contains Pb in products exempted by EU RoHS directive. (Contains Pb in sealing glass, high melting temperature type solder or other.)</p>
	<p>► Designed for automotive general equipment.</p>
	<p>► Designed for automotive applications related to driving and safety.</p>

NOTICE : PLEASE READ CAREFULLY BELOW BEFORE THE USE OF THIS DOCUMENT

1. The content of this document is subject to change without notice. Before purchasing or using Epson products, please contact with sales representative of Seiko Epson Corporation ("Epson") for the latest information and be always sure to check the latest information published on Epson's official web sites and resources.
2. This document may not be copied, reproduced, or used for any other purposes, in whole or in part, without Epson's prior consent.
3. Information provided in this document including, but not limited to application circuits, programs and usage, is for reference purpose only. Epson makes no guarantees against any infringements or damages to any third parties' intellectual property rights or any other rights resulting from the information. This document does not grant you any licenses, any intellectual property rights or any other rights with respect to Epson products owned by Epson or any third parties.
4. Epson has prepared this document carefully to be accurate and dependable, but Epson does not guarantee that the information is always accurate and complete. Epson assumes no responsibility for any damages you incurred due to any misinformation in this document.
5. Epson products listed in this document and our associated technologies shall not be used in any equipment or systems that laws and regulations in Japan or any other countries prohibit to manufacture, use or sell. Furthermore, Epson products and our associated technologies shall not be used for the purposes of military weapons development (e.g. mass destruction weapons), military use, or any other military applications. If exporting Epson products or our associated technologies, please be sure to comply with the Foreign Exchange and Foreign Trade Control Act in Japan, Export Administration Regulations in the U.S.A (EAR) and other export-related laws and regulations in Japan and any other countries and to follow their required procedures.
6. Epson assumes no responsibility for any damages (whether direct or indirect) caused by or in relation with your non-compliance with the terms and conditions in this document or for any damages (whether direct or indirect) incurred by any third party that you give, transfer or assign Epson products.
7. For more details or other concerns about this document, please contact our sales representative.
8. Company names and product names listed in this document are trademarks or registered trademarks of their respective companies.

● Disclaimer

1. Epson products are designed for use in general electronic equipment applications that do not require extremely high reliability or safety.
2. Epson does not represent or warrant that its products will not cause a failure for any particular application, except for cases where the failure is a direct result caused by defects in materials and workmanship of this product.
 If a product fails due to defects in materials and workmanship, to the maximum extent permitted by law, we will, at our sole discretion, refund or replace the affected product.
3. When products for used directly or indirectly in certain devices or applications (ex. Nuclear power, aerospace, infrastructure facilities, medical equipment, etc.) which are connected to or affect safety of human life or property, Customer is solely responsible for determining if the products and respective specifications are suitable for the intended use in particular customer applications.
 Customer shall implement necessary and proper safety design and measures (including redundant design, malfunction prevention design, etc.) to ensure reliability and safety before using the products in/with customer's Equipment.
4. For the products designed for automotive applications, the products comply with AEC-Q100 or AEC-Q200.
 Products do not comply with ISO 26262 (Products are not categorized to ASIL A, B, C and D).
5. No dismantling, analysis, reverse engineering, modification, alteration, adaptation, reproduction, etc., of Epson products is allowed.
 Furthermore, any defects caused by this are not covered by the warranty.

©Seiko Epson Corporation 2025