

REAL TIME CLOCK MODULE (SPI-Bus)

Built-in 32.768 kHz-DTCXO, High Stability

RX-4803SA / LC

Product Number
RX-4803SA : X1B000131xxx00
RX-4803LC : X1B000122xxx00
RX-4803LC UB : X1B000122000200

- Built in frequency adjusted 32.768 kHz crystal unit and DTCXO.
- 1/100s resolution Time register
- Interface Type : 4-wire serial interface
- Interface voltage range : 1.6 V to 5.5 V
- Temp. compensated voltage range : 2.2 V to 5.5 V
- Clock supply voltage range : 1.6 V to 5.5 V
- Selectable clock output (32.768 kHz, 1024 Hz, 1 Hz)
- The various functions include full calendar, alarm, timer, EVIN input.



RX-4803SA



RX-4803LC

Block diagram

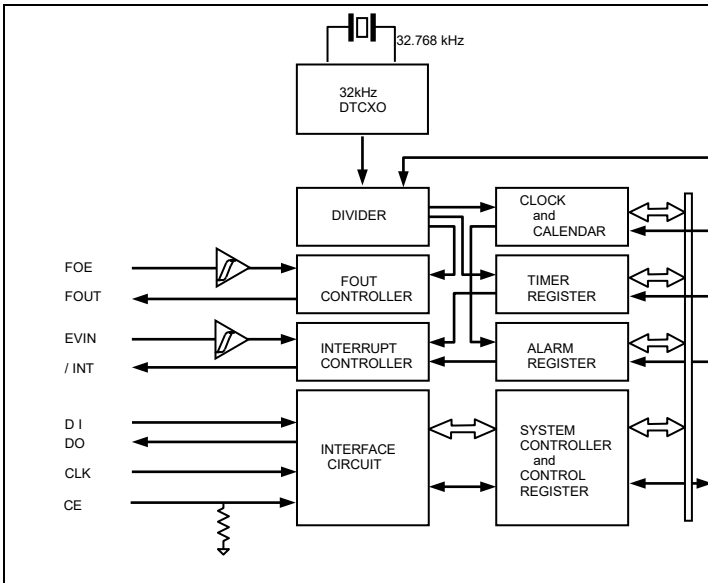

Overview

- **High Stability**
 - UA $\pm 3.4 \times 10^{-6}$ / -40 °C to +85 °C (Equivalent to ± 9 seconds of month deviation)
 - UB $\pm 5.0 \times 10^{-6}$ / -40 °C to +85 °C (Equivalent to ± 13 seconds of month deviation)
 - UC $\pm 5.0 \times 10^{-6}$ / -30 °C to +70 °C
 - AA $(+5 \pm 5.0) \times 10^{-6}$ / +25 °C
- **High Resolution:** 1/100s Time register with capture buffer
- **32.768 kHz frequency output function**
 - FOUT pin output (C-MOS output), CL=30 pF
 - Output selectable: 32.768 kHz, 1024 Hz, 1 Hz
- **The various interrupt**
 - Timer Function can be set between 1/ 4096 second and 4095 minutes.
 - Alarm Function can be set to day of week, day, hour, or minute.
 - EVIN input.
- **Time synchronize function with 1PPS signal input**
- **Register compatibility:** upper compatible with RX-4801.

*It is possible to use it by the terminal connection as 32.768 kHz-DTCXO.

Pin Function

Signal Name	I / O	Function
CE	input	The chip enable input pin.
CLK	input	The shift clock input pin for serial data transfer.
FOUT	Output	The pin outputs the reference clock signal. (CMOS output)
TEST	input	Use by the manufacture for testing. (Do not connect externally. RX-4803SA only.)
VDD	-	Connected to a positive power supply
FOE	input	The input pin for the FOUT output control.
EVIN	input	External event input. Open is prohibited
/INT	Output	Interrupt output (N-ch. open drain).
GND	-	Connected to a ground
T2(VPP)	-	Use by the manufacture for testing. (Do not connect externally.)
DO	Output	The data output pin for serial data transfer.
DI	input	The data input pin for serial data transfer.

When it is replaced to 4803SA from 4801SA, please do not make open state of 9pin.

Terminal connection / External dimensions

(Unit:mm)

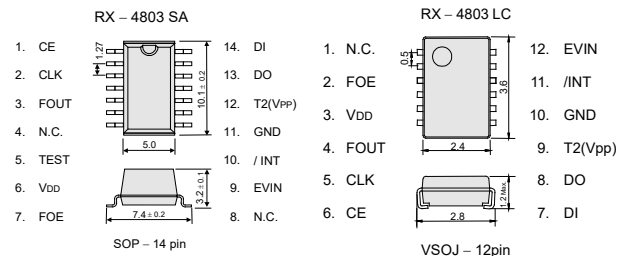

The metal case inside of the molding compound may be exposed on the top or bottom of this product. This purely cosmetic and does not have any effect on quality, reliability or electrical specs.

Prohibition of use of glue after a mount of a product
 An LC package product cannot use glue and resin coating.
 When such a processing is necessary, please examine a CE package product.

Specifications (characteristics)

* Refer to application manual for details.

Electrical Characteristics

Item	Symbol	Conditions	Min.	Typ.	Max.	Unit	
Interface voltage	V _{DD}	Interface voltage	1.6	3.0	5.5	V	
Temp. compensated Voltage	V _{TEM}	Temp. compensated voltage	2.2	3.0	5.5	V	
Clock supply voltage	V _{CLK}	-	1.6	3.0	5.5	V	
Operating temperature	T _{OPR}	No condensation	-40	+25	+85	°C	
Stability	Δf/f	UA	Ta = -40 °C to +85 °C	±3.4 *1		× 10 ⁻⁶	
		UB	Ta = -40 °C to +85 °C	±5.0 *2			
		UC	Ta = -30 °C to +70 °C				
		AA	Ta = +25 °C	5 ± 5.0 *3			
Current consumption (1)	I _{DD1}	Backup Mode FOE = GND, /INT = V _{DD} FOUT output : OFF	V _{DD} = 5V	-	0.75	3.4	μA
Current consumption (2)	I _{DD2}		V _{DD} = 3V	-	0.75	2.1	μA

*1) Equivalent to ± 9 seconds of month deviation. *2) Equivalent to ± 13 seconds of month deviation.

*3) Equivalent to ± 13 seconds of month deviation. (excluding offset)

32.768 kHz-DTCXO Frequency temperature characteristics (Example)

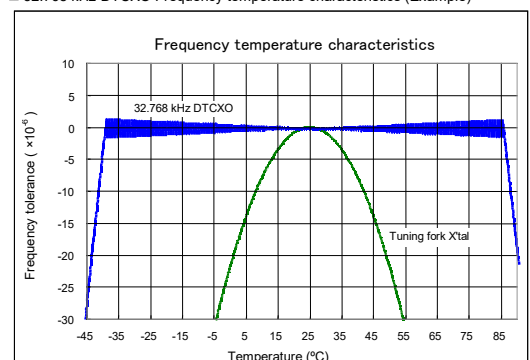

► Explanation of the mark that are using it for the catalog

	<p>► Pb free.</p>
	<p>► Complies with EU RoHS directive. *About the products without the Pb-free mark. Contains Pb in products exempted by EU RoHS directive. (Contains Pb in sealing glass, high melting temperature type solder or other.)</p>
	<p>► Designed for automotive general equipment.</p>
	<p>► Designed for automotive applications related to driving and safety.</p>

NOTICE : PLEASE READ CAREFULLY BELOW BEFORE THE USE OF THIS DOCUMENT

1. The content of this document is subject to change without notice. Before purchasing or using Epson products, please contact with sales representative of Seiko Epson Corporation ("Epson") for the latest information and be always sure to check the latest information published on Epson's official web sites and resources.
2. This document may not be copied, reproduced, or used for any other purposes, in whole or in part, without Epson's prior consent.
3. Information provided in this document including, but not limited to application circuits, programs and usage, is for reference purpose only. Epson makes no guarantees against any infringements or damages to any third parties' intellectual property rights or any other rights resulting from the information. This document does not grant you any licenses, any intellectual property rights or any other rights with respect to Epson products owned by Epson or any third parties.
4. Epson has prepared this document carefully to be accurate and dependable, but Epson does not guarantee that the information is always accurate and complete. Epson assumes no responsibility for any damages you incurred due to any misinformation in this document.
5. Epson products listed in this document and our associated technologies shall not be used in any equipment or systems that laws and regulations in Japan or any other countries prohibit to manufacture, use or sell. Furthermore, Epson products and our associated technologies shall not be used for the purposes of military weapons development (e.g. mass destruction weapons), military use, or any other military applications. If exporting Epson products or our associated technologies, please be sure to comply with the Foreign Exchange and Foreign Trade Control Act in Japan, Export Administration Regulations in the U.S.A (EAR) and other export-related laws and regulations in Japan and any other countries and to follow their required procedures.
6. Epson assumes no responsibility for any damages (whether direct or indirect) caused by or in relation with your non-compliance with the terms and conditions in this document or for any damages (whether direct or indirect) incurred by any third party that you give, transfer or assign Epson products.
7. For more details or other concerns about this document, please contact our sales representative.
8. Company names and product names listed in this document are trademarks or registered trademarks of their respective companies.

● Disclaimer

1. Epson products are designed for use in general electronic equipment applications that do not require extremely high reliability or safety.
2. Epson does not represent or warrant that its products will not cause a failure for any particular application, except for cases where the failure is a direct result caused by defects in materials and workmanship of this product.
 If a product fails due to defects in materials and workmanship, to the maximum extent permitted by law, we will, at our sole discretion, refund or replace the affected product.
3. When products for used directly or indirectly in certain devices or applications (ex. Nuclear power, aerospace, infrastructure facilities, medical equipment, etc.) which are connected to or affect safety of human life or property, Customer is solely responsible for determining if the products and respective specifications are suitable for the intended use in particular customer applications.
 Customer shall implement necessary and proper safety design and measures (including redundant design, malfunction prevention design, etc.) to ensure reliability and safety before using the products in/with customer's Equipment.
4. For the products designed for automotive applications, the products comply with AEC-Q100 or AEC-Q200.
 Products do not comply with ISO 26262 (Products are not categorized to ASIL A, B, C and D).
5. No dismantling, analysis, reverse engineering, modification, alteration, adaptation, reproduction, etc., of Epson products is allowed.
 Furthermore, any defects caused by this are not covered by the warranty.

©Seiko Epson Corporation 2025