

**Built-in EVENT RECORDER FUNCTION
SERIAL-INTERFACE REAL TIME CLOCK MODULE**

RX-5412 SF

- Built in frequency adjusted 32.768 kHz crystal unit.
- Interface Type : 4-wire serial interface
- Operating voltage range : 2.5 V to 5.5 V
- Wide Timekeeper voltage range : 1.4 V to 5.5 V
- Low backup current : 0.5 μ A / 3 V (Typ.)
- Built-in SRAM : Built-in 2048 bit (8 bit \times 256)
- The various functions include full calendar, alarm, timer, event record, watch dog timer, automatic power switching function.



Product Number (Please contact us)
X1B000082xxxx00

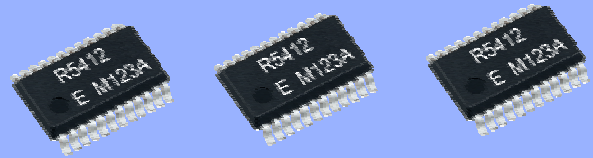

Actual size



NEW

Block diagram

Overview

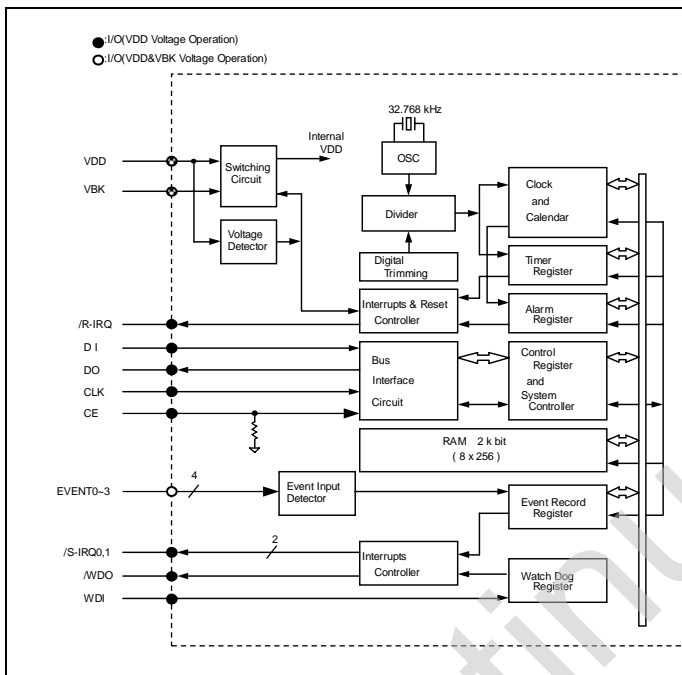

- **Event recorder function**
 - 4 input ports are available for event recorder request.
 - Event recorder data are recorded in inside memory according to user setting.
- **Power switching circuit**
 - When VDD voltage are down, real time clock module power source are switched to VBAT from VDD.
- **Built-in SRAM (256 bytes)**
 - Available built in SRAM for users memory and event recorder memory.
- **Watch dog timer function**
 - Watch dog time, it can set from 1.95 ms to 468.75 ms
- **Voltage drop detection**
 - When real time clock module return from backup mode, this function indicate The reliability of real time clock module data.
- **Periodic timer function**
 - In a timer period, it can set from 1/4096 seconds to 4095 minutes.
- **Alarm function**
 - Alarm by combination of day of week, day, hours, and minutes.

Pin Function

External dimensions

(Unit:mm)

Signal name	Pin No.	I / O	Function	Signal name	Pin No.	I / O	Function
Vss	1	-	GND	(Vss)	24	-	
EVENT0	2	Input	Event input	(Vss)	23	-	
EVENT1	3	Input	Event input	(Vss)	22	-	
VBK	4	-	Backup power supply	(Vss)	21	-	
EVENT2	5	Input	Event input	(Vss)	20	-	
(Vss)	6	-		(Vss)	19	-	
EVENT3	7	Input	Event input	/S-IRQ1	18	Output	Event record interrupt output (open drain)
CE	8	Input	Chip enabled input	/S-IRQ0	17	Output	Event record interrupt output (open drain)
CLK	9	Input	Clock input pin for serial data transmission	WDI	16	Input	Watch dog input (open drain)
DO	10	Output	Data output pin for serial data transmission	WDO	15	Output	Watch dog output (open drain)
DI	11	Input	Data input pin for serial data transmission	N.C.	14	-	-
/R-IRQ	12	Output	RTC function interrupt output (open drain)	V _{DD}	13	-	Power supply

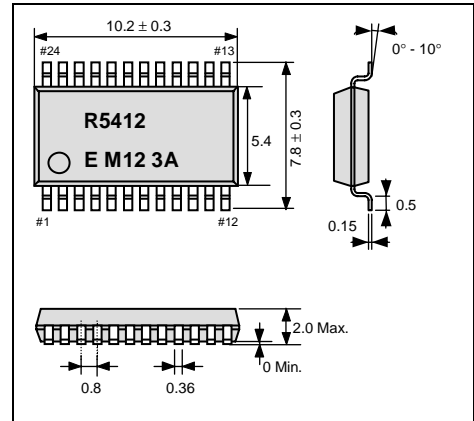

Specifications (characteristics)

*Refer to application manual for details.

Electrical Characteristics

Item	Symbol	Condition	Min.	Typ.	Max.	Unit
Power voltage	V _{DD}	-	2.5	3.0	5.5	V
Clock voltage	V _{CLK}	-	1.4	3.0	5.5	V
Operating temperature	T _{OPR}	-	-40	+25	+85	°C
Frequency tolerance	$\Delta f / f$	T _a = +25 °C, V _{DD} = 3.0 V		5 ± 23 *		$\times 10^{-6}$
Current Consumption	I _{DD1}	Back up operation , CE = GND , /IRQ = OFF		0.5	1.0	μ A
	I _{DD2}			0.5	1.0	

*Equivalent to 1 minute of monthly deviation.