

REAL TIME CLOCK MODULE (I²C-Bus)

Built-in 32.768 kHz DTCXO, High Stability,
Power switching



Product Number
 1,000 pcs / Reel
RX8900SA UA: X1B000292000100
RX8900SA UB: X1B000292000200
RX8900SA UC: X1B000292000300
 2,000 pcs / Reel
RX8900CE UA: X1B000301000100
RX8900CE UB: X1B000301000200
RX8900CE UC: X1B000301000300

RX8900SA / RX8900CE

- Built-in frequency adjusted 32.768 kHz crystal unit and DTCXO
- Interface Type : I²C-Bus
- Interface voltage range : 2.5 V to 5.5 V
- Temp. compensated voltage range : 2.0 V to 5.5 V
- Timekeeping voltage range : 1.6 V to 5.5 V
- Auto power switching function : Automatically switches to backup power supply by monitoring the VDD voltage
- Interrupt output : Wake up every minute or every second
- Alarm interruption : Day, date, hour, minute
- Auto repeat wakeup timer interruption



RX8900SA



RX8900CE

(10.1 x 7.4 mm, t = 3.3 mm Max.) (3.2 x 2.5 mm, t = 1.0 mm Max.)

Block diagram

Overview

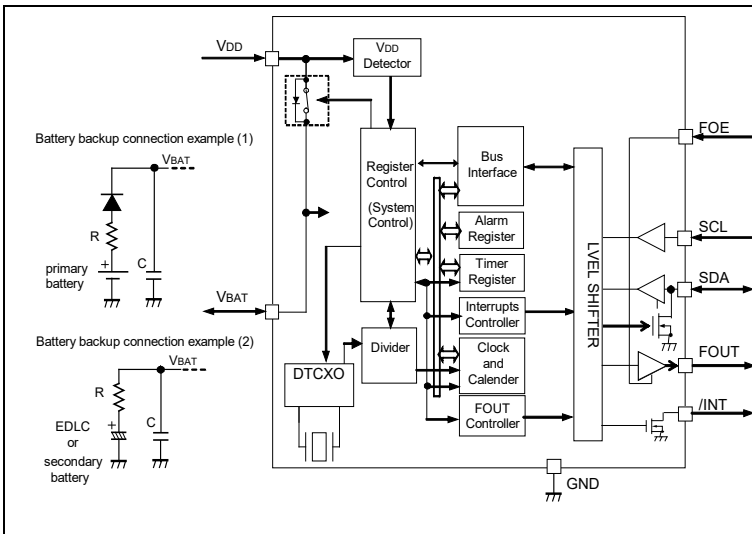

- Interface type
I²C-Bus interface Fast-Mode 400 kHz
- High stability
 UA: $\pm 3.4 \times 10^{-6}$ / -40 °C to +85 °C (equiv. to ± 9 s of mo. deviation)
 UB: $\pm 5.0 \times 10^{-6}$ / -40 °C to +85 °C (equiv. to ± 13 s of mo. deviation)
 UC: $\pm 5.0 \times 10^{-6}$ / -30 °C to +70 °C (equiv. to ± 13 s of mo. deviation)
- Auto power switch function
 The VDD voltage is monitored and it switches to the backup power supply by the automatic operation
 Backup power supply switching voltage 1.9 V Min.
- Clock output function
 Output frequency is selectable from 32.768 kHz, 1024 Hz, 1 Hz
- Wakeup timer function
 Selectable from 244 μ s to 2.8 days (12 bit x 1 ch.)
 Timer source clock selectable from 1/60 Hz, 1 Hz, 64 Hz, 4096 Hz
 Auto release after interrupt output from /INT pin at timer completes
 This operation is auto repeat with a selected cycle, it can be used like a watchdog timer
- Alarm function
 It is possible program from day to minute
- Temp. sensor function
 Available readout temperature data from embedded temp sensor

Pin Function

Terminal connection / External dimensions

(Unit: mm)

Signal Name	I / O	Function
T1	-	Test pin in the factory (Do not connect externally)
SCL	Input	Serial clock input pin
FOUT	Output	Frequency output pin (CMOS) (frequency selection: 32.768 kHz, 1024 Hz, 1 Hz)
VBAT	-	This is a power supply pin for backup battery Connect an EDLC, a secondary battery, a primary battery. In the backup voltage range, supplied to IC, from this pin
VDD	-	Power-supply pin
FOE	Input	The FOUT output control pin
/INT	Output	Interrupt output (N-ch. open drain).
GND	-	Ground pin
T2	-	Test pin in the factory (Do not connect externally)
SDA	Input / Output	Serial data input and output pin

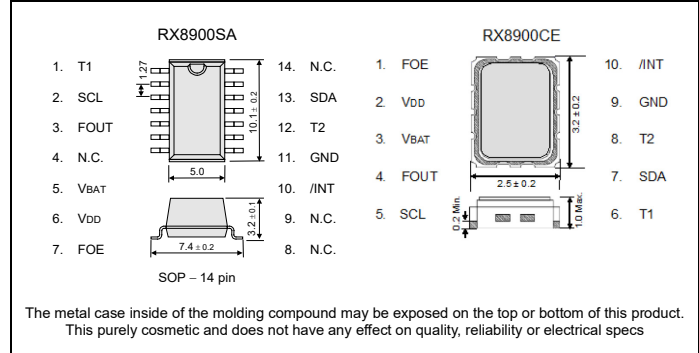

Specifications (characteristics)

* Refer to application manual for details

■ Electrical Characteristics

Item	Symbol	Conditions	Min.	Typ.	Max.	Unit	
Operating voltage	VDD	-	2.5	3.0	5.5	V	
Temp. compensated Voltage	VTEM	-	2.0	3.0	5.5	V	
Clock supply voltage	VCLK	-	1.6	3.0	5.5	V	
VDD detect voltage (3)	VDET3	-	2.3	2.4	2.5	V	
Operating temperature	Ta	-	-40	+25	+85	°C	
Stability	$\Delta f / f$	UA	Ta = -40 °C to +85 °C		± 3.4	$\times 10^{-6}$	
		UB	Ta = -40 °C to +85 °C		± 5.0		
		UC	Ta = -30 °C to +70 °C				
Current consumption (1)	I _{DD1}	fSCL = 0 Hz, /INT = VDD, FOE = GND, VDD = VBAT, FOUT: OFF, Temp. Compensation interval 2.0 s	VDD = 5 V	-	0.72	1.5	μ A
Current consumption (2)	I _{DD2}		VDD = 3 V	-	0.70	1.4	μ A

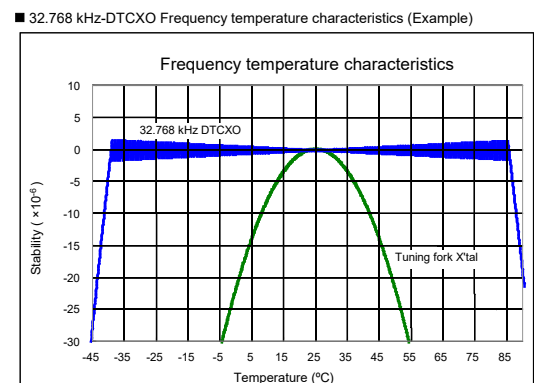

► Explanation of the mark that are using it for the catalog

	<p>► Pb free.</p>
	<p>► Complies with EU RoHS directive. *About the products without the Pb-free mark. Contains Pb in products exempted by EU RoHS directive. (Contains Pb in sealing glass, high melting temperature type solder or other.)</p>
	<p>► Designed for automotive general equipment.</p>
	<p>► Designed for automotive applications related to driving and safety.</p>

NOTICE : PLEASE READ CAREFULLY BELOW BEFORE THE USE OF THIS DOCUMENT

1. The content of this document is subject to change without notice. Before purchasing or using Epson products, please contact with sales representative of Seiko Epson Corporation ("Epson") for the latest information and be always sure to check the latest information published on Epson's official web sites and resources.
2. This document may not be copied, reproduced, or used for any other purposes, in whole or in part, without Epson's prior consent.
3. Information provided in this document including, but not limited to application circuits, programs and usage, is for reference purpose only. Epson makes no guarantees against any infringements or damages to any third parties' intellectual property rights or any other rights resulting from the information. This document does not grant you any licenses, any intellectual property rights or any other rights with respect to Epson products owned by Epson or any third parties.
4. Epson has prepared this document carefully to be accurate and dependable, but Epson does not guarantee that the information is always accurate and complete. Epson assumes no responsibility for any damages you incurred due to any misinformation in this document.
5. Epson products listed in this document and our associated technologies shall not be used in any equipment or systems that laws and regulations in Japan or any other countries prohibit to manufacture, use or sell. Furthermore, Epson products and our associated technologies shall not be used for the purposes of military weapons development (e.g. mass destruction weapons), military use, or any other military applications. If exporting Epson products or our associated technologies, please be sure to comply with the Foreign Exchange and Foreign Trade Control Act in Japan, Export Administration Regulations in the U.S.A (EAR) and other export-related laws and regulations in Japan and any other countries and to follow their required procedures.
6. Epson assumes no responsibility for any damages (whether direct or indirect) caused by or in relation with your non-compliance with the terms and conditions in this document or for any damages (whether direct or indirect) incurred by any third party that you give, transfer or assign Epson products.
7. For more details or other concerns about this document, please contact our sales representative.
8. Company names and product names listed in this document are trademarks or registered trademarks of their respective companies.

● Disclaimer

1. Epson products are designed for use in general electronic equipment applications that do not require extremely high reliability or safety.
2. Epson does not represent or warrant that its products will not cause a failure for any particular application, except for cases where the failure is a direct result caused by defects in materials and workmanship of this product.
 If a product fails due to defects in materials and workmanship, to the maximum extent permitted by law, we will, at our sole discretion, refund or replace the affected product.
3. When products for used directly or indirectly in certain devices or applications (ex. Nuclear power, aerospace, infrastructure facilities, medical equipment, etc.) which are connected to or affect safety of human life or property, Customer is solely responsible for determining if the products and respective specifications are suitable for the intended use in particular customer applications.
 Customer shall implement necessary and proper safety design and measures (including redundant design, malfunction prevention design, etc.) to ensure reliability and safety before using the products in/with customer's Equipment.
4. For the products designed for automotive applications, the products comply with AEC-Q100 or AEC-Q200.
 Products do not comply with ISO 26262 (Products are not categorized to ASIL A, B, C and D).
5. No dismantling, analysis, reverse engineering, modification, alteration, adaptation, reproduction, etc., of Epson products is allowed.
 Furthermore, any defects caused by this are not covered by the warranty.

©Seiko Epson Corporation 2025