

**Crystal Oscillator (SPXO)**

- Package size (3.2 mm × 2.5 mm × 1.05 mm)
- Fundamental mode SPXO
- Output: HCSL
- Reference weight Typ.26 mg

**[ 1 ] Product Number / Product Name / Marking**

(1-1) Product Number / Ordering Code

**X1G0051410002xx**

Last 2 digits code(xx) defines Quantity.

The standard is "00", 2 000 pcs/Reel.

(1-2) Product Name / Model Name

**SG3225HBN 156.250000MHz CJGA****[ 2 ] Operating Range**

Parameter	Symbol	Specifications			Unit	Conditions
		Min.	Typ.	Max.		
Supply voltage	V <sub>CC</sub>	3.135	3.3	3.465	V	-
	GND	0	-	0	V	-
Operating temperature range	T <sub>use</sub>	-40	-	85	°C	-
HCSL load condition	L <sub>HCSL</sub>	-	50	-	Ω	-
	R <sub>s</sub>	-	33	-	Ω	-

**[ 3 ] Frequency Characteristics**

(Unless stated otherwise [ 2 ] Operating Range)

Parameter	Symbol	Specifications			Unit	Conditions
		Min.	Typ.	Max.		
Output frequency	f <sub>o</sub>	-	156.250000	-	MHz	-
Frequency tolerance *1	f <sub>tol</sub>	-50	-	+50	×10 <sup>-6</sup>	T <sub>use</sub>

\*1 Frequency tolerance includes Initial frequency tolerance, Frequency / temperature characteristics, Frequency / voltage coefficient, and aging (10 years, +25 °C).

**[ 4 ] Electrical Characteristics**

(Unless stated otherwise [ 2 ] Operating Range)

Parameter	Symbol	Specifications			Unit	Conditions
		Min.	Typ.	Max.		
Start-up time	t <sub>str</sub>	-	-	10	ms	t = 0 at 90 % V <sub>CC</sub>
Current consumption	I <sub>CC</sub>	-	25	35	mA	OE = V <sub>CC</sub> , with HCSL load condition
Disable current	I <sub>dis</sub>	-	-	15	mA	OE = GND
Output voltage	V <sub>OH</sub>	0.66	-	0.85	V	DC characteristics
	V <sub>OL</sub>	-0.15	-	0.15	V	DC characteristics
Differential swing	V <sub>SW</sub>	0.3	-	-	V	-
Crossing voltage	V <sub>CR</sub>	0.25	-	0.55	V	-
Differential output rise slew rate	R <sub>r</sub>	1	-	4	V/ns	Between -0.15 V and 0.15 V of differential output
Differential output fall slew rate	R <sub>f</sub>	1	-	4	V/ns	Between -0.15 V and 0.15 V of differential output
Symmetry	SYM	45	50	55	%	At output crossing point
Input voltage	V <sub>IH</sub>	70 % V <sub>CC</sub>	-	-	V	OE Terminal
	V <sub>IL</sub>	-	-	30 % V <sub>CC</sub>	V	OE Terminal
Output disable time (OE)	t <sub>stp_oe</sub>	-	-	100	ns	OE terminal HIGH → LOW
Output enable time (OE)	t <sub>sta_oe</sub>	-	-	100	ns	OE terminal LOW → HIGH

**[ For other general specifications, please refer to the attached Full Data Sheet below ]**

## Low Jitter Crystal Oscillator: SG3225HBN

### Features

- HCSL Output, Low Jitter SPXO
- Phase Jitter: 180 fs Max.  
fo = 100 MHz, 12 kHz to 20 MHz RMS
- Frequency range: 100 MHz to 325 MHz
- Supply Voltage Options: 2.5 V Typ. / 3.3 V Typ.
- Frequency Tolerance Options:  $\pm 50 \times 10^{-6}$ ,  $\pm 100 \times 10^{-6}$
- Operating Temperature Options:  
-40 °C to +85 °C and -40 °C to +105 °C

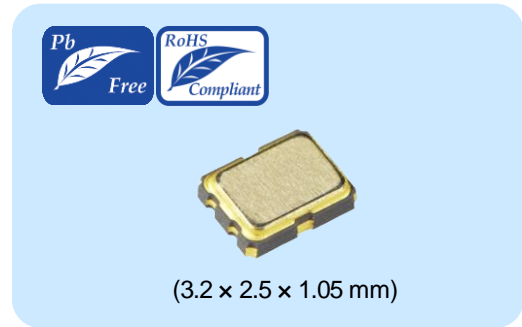

### Applications

- Server
- NIC, HBA
- PCI Express® serial communications
- Various high-speed serial communications

### Description

SG3225HBN is a low jitter, HCSL output crystal oscillator. This product is excellent as a PCI Express® reference clock meeting PCIe® 1.0 to PCIe® 6.2 jitter requirements

### Outline Drawing

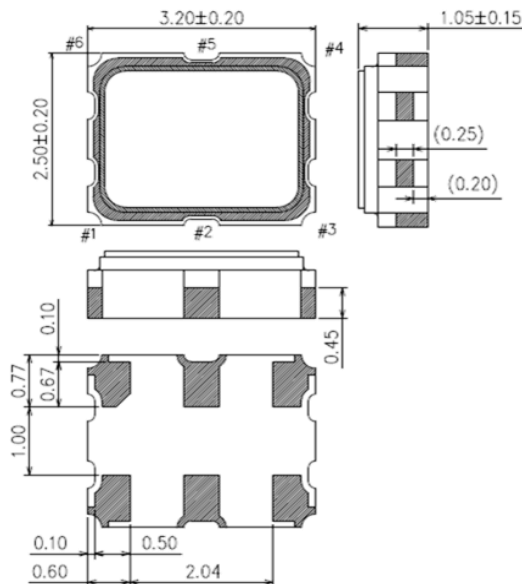

### Typical Performance

Compatible with PCIe® Jitter Requirement\* [Units: ps]

	Gen3	Gen4	Gen5	Gen6
PCIe CC jitter limit	1.0 Max.	0.5 Max.	0.15 Max.	0.1 Max.
SG3225HBN	0.04 Typ.	0.04 Typ.	0.02 Typ.	0.01 Typ.

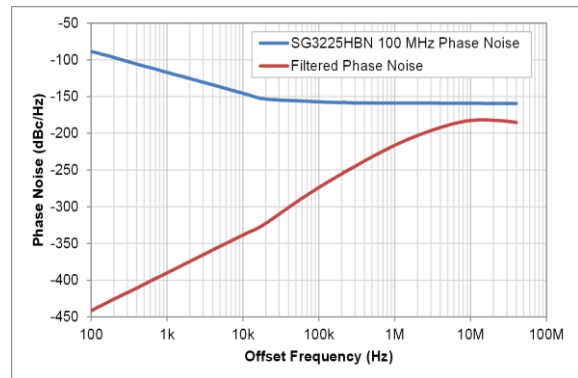

\* PCI Express® Base Specification Revision 6.2  
8.6.6 Common Refclk Rx Architecture (CC)  
8.6.7 Jitter Limits for Refclk Architectures

### Terminal Assignment

Pin #	Connection	Function	
#1	OE	OE terminal / active high	
		OE function	
		"H" or OPEN	Specified frequency is output: Enable
		"L"	Output becomes high impedance: Disable
#2	NC	—	
#3	GND	GND terminal	
#4	OUT	Output terminal (Positive)	
#5	$\overline{\text{OUT}}$	Output terminal (Negative)	
#6	V <sub>CC</sub>	V <sub>CC</sub> terminal	

\* PCI Express and PCIe are a registered trademark of PCI-SIG

## [ 1 ] Product Number / Product Name

(1-1) Product Number

X1G005141xxx00 (Please contact Epson for details)

(1-2) Product Name (Standard Form)

SG3225 H BN 156.250000MHz C J G A (⑤⑥: Unavailable code JH)  
① ② ③ ④ ⑤ ⑥ ⑦

① Model ② Output(H: HCSSL) ③ Frequency ④ Supply voltage

⑤ Frequency tolerance ⑥ Operating temperature ⑦ Internal identification code("A" is default)

④ Supply voltage	
D	2.5 V Typ.
C	3.3 V Typ.

⑤ Frequency tolerance	
J	$\pm 50 \times 10^{-6}$
L	$\pm 100 \times 10^{-6}$

⑥ Operating temperature	
G	-40 °C to +85 °C
H	-40 °C to +105 °C

## [ 2 ] Absolute Maximum Ratings

Parameter	Symbol	Specification			Unit	Conditions
		Min.	Typ.	Max.		
Maximum supply voltage	$V_{CC}$	-0.5	-	4	V	-
Input voltage	$V_{in}$	-0.3	-	$V_{CC} + 0.3$	V	OE terminal
Storage temperature range	$T_{stg}$	-55	-	125	°C	

## [ 3 ] Operating Range

Parameter	Symbol	Specification			Unit	Conditions
		Min.	Typ.	Max.		
Supply voltage	$V_{CC}$	2.375	2.5	2.625	V	Suffix: D
		3.135	3.3	3.465	V	Suffix: C
Supply voltage	GND	0.0	0.0	0.0	V	
Operating temperature range	$T_{use}$	-40	+25	+85	°C	Suffix: G
		-40	+25	+105	°C	Suffix: H
HCSSL load condition	$L_{HCSSL}$	50			$\Omega$	

\* Power supply startup time (0 % $V_{CC}$ →90 % $V_{CC}$ ) should be more than 150  $\mu$ s\* A 0.1  $\mu$ F and a 10  $\mu$ F bypass capacitor should be connected between  $V_{CC}$  and GND pins located close to the device

## [ 4 ] Frequency Characteristics

(Unless stated otherwise [ 3 ] Operating Range)

Parameter	Symbol	Specification			Unit	Conditions
		Min.	Typ.	Max.		
Output frequency *1	$f_o$	100	-	325	MHz	
Frequency tolerance *2	$f_{tol}$	-50	-	+50	$\times 10^{-6}$	Suffix: J $T_{use}$ : G
		-100	-	+100	$\times 10^{-6}$	Suffix: L $T_{use}$ : G or H

\*1 Please contact Epson for available frequencies

\*2 Frequency tolerance includes initial frequency tolerance, temperature variation, supply voltage change and 10 years aging at +25 °C

## [ 5 ] Electrical Characteristics

(Unless stated otherwise [ 3 ] Operating Range)

Parameter	Symbol	Specification			Unit	Conditions
		Min.	Typ.	Max.		
Startup time	t <sub>str</sub>	-	-	10	ms	t = 0 at 90 %V <sub>CC</sub>
Current consumption	I <sub>CC</sub>	-	25	35	mA	
Disable current	I <sub>dis</sub>	-	-	15	mA	OE = GND
Differential output rise slew rate	R <sub>r</sub>	1	-	4	V/ns	Between -0.15 V and 0.15 V of differential output
Differential output fall slew rate	R <sub>f</sub>	1	-	4	V/ns	
Symmetry	SYM	45	50	55	%	At output crossing point
Output voltage	V <sub>OH</sub>	0.66	-	0.85	V	DC characteristics, fo ≤ 200 MHz
		0.57	-	0.77	V	DC characteristics, fo > 200 MHz
	V <sub>OL</sub>	-0.15	-	0.15	V	DC characteristics
Differential swing	V <sub>SW</sub>	0.3	-	-	V	
Crossing voltage	V <sub>CR</sub>	0.25	-	0.55	V	
Crossing voltage variation	V <sub>DCR</sub>	-	-	0.14	V	
Input voltage	V <sub>IH</sub>	70 % V <sub>CC</sub>	-	-	V	OE terminal
	V <sub>IL</sub>	-	-	30 % V <sub>CC</sub>	V	
Output disable time (OE)	t <sub>stp_oe</sub>	-	-	100	ns	100 MHz ≤ fo ≤ 200 MHz
		-	-	200	ns	200 MHz < fo ≤ 325 MHz
Output enable time (OE)	t <sub>sta_oe</sub>	-	-	100	ns	100 MHz ≤ fo ≤ 200 MHz
		-	-	200	ns	200 MHz < fo ≤ 325 MHz
Phase jitter (12 kHz to 20 MHz)	t <sub>pJ</sub>	-	-	180	fs	fo=100 MHz
		-	-	160	fs	fo=125 MHz
		-	-	140	fs	fo=156.25 MHz
		-	-	125	fs	fo=200 MHz
		-	-	110	fs	fo=322.265625 MHz

## [ 6 ] Thermal resistance (For reference only)

Parameter	Symbol	Specification			Unit	Conditions
		Min.	Typ.	Max.		
Junction temperature	T <sub>j</sub>	-	-	125	°C	
Junction to case	θ <sub>jc</sub>	-	97.9	-	°C/W	
Junction to ambient	θ <sub>ja</sub>	-	155.4	-	°C/W	

[ 7 ] Typical Performance Characteristics (For reference only)

The following data shows typical performance characteristics

(7-1) Frequency / Temperature Characteristics

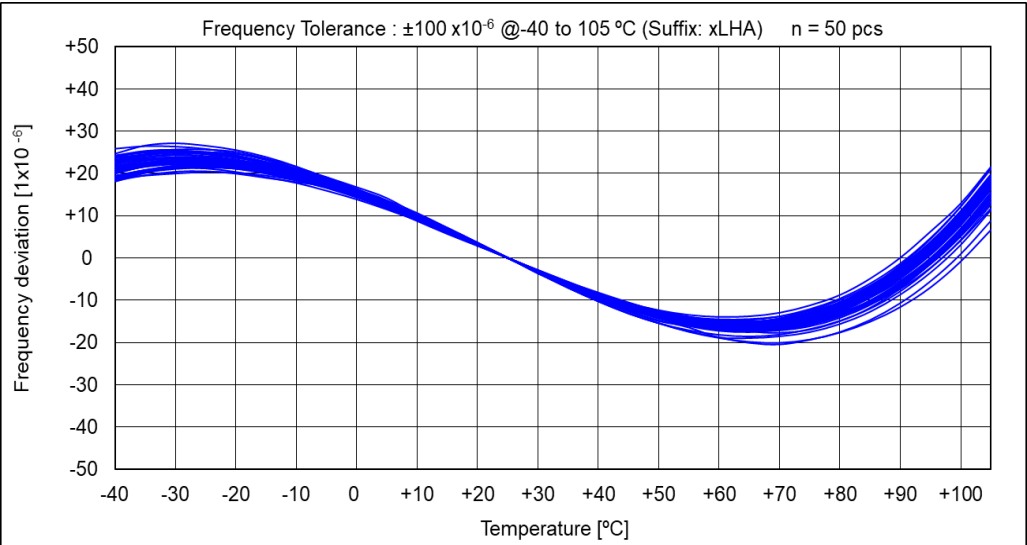
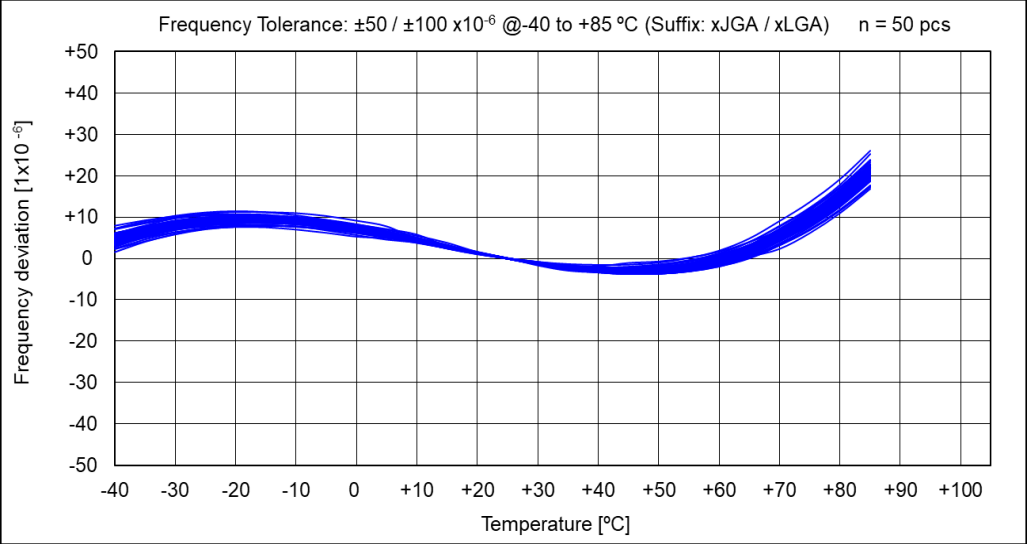

## (7-2) Current Consumption

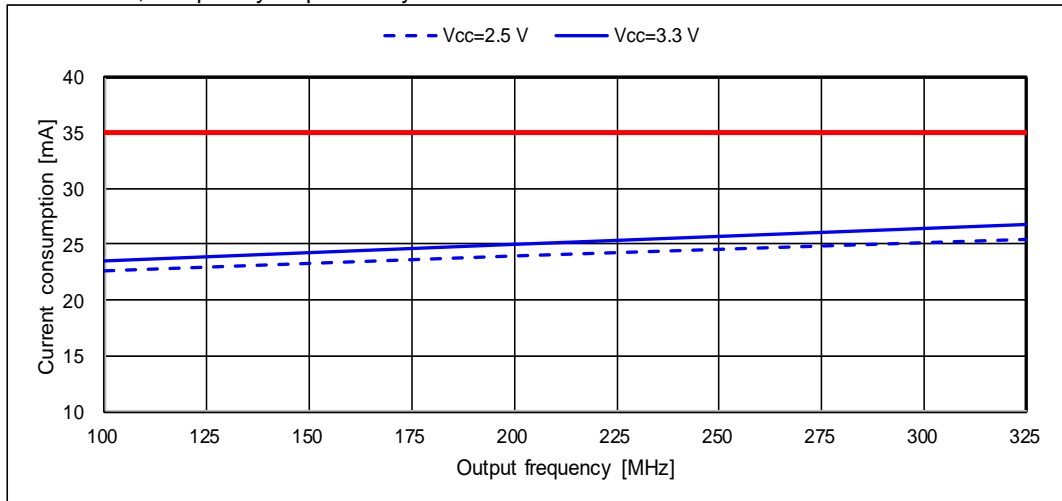
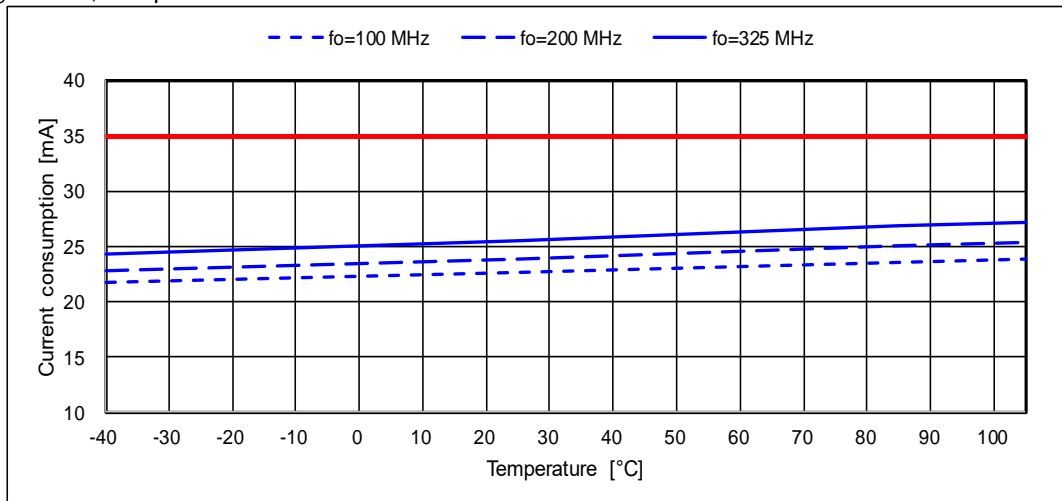
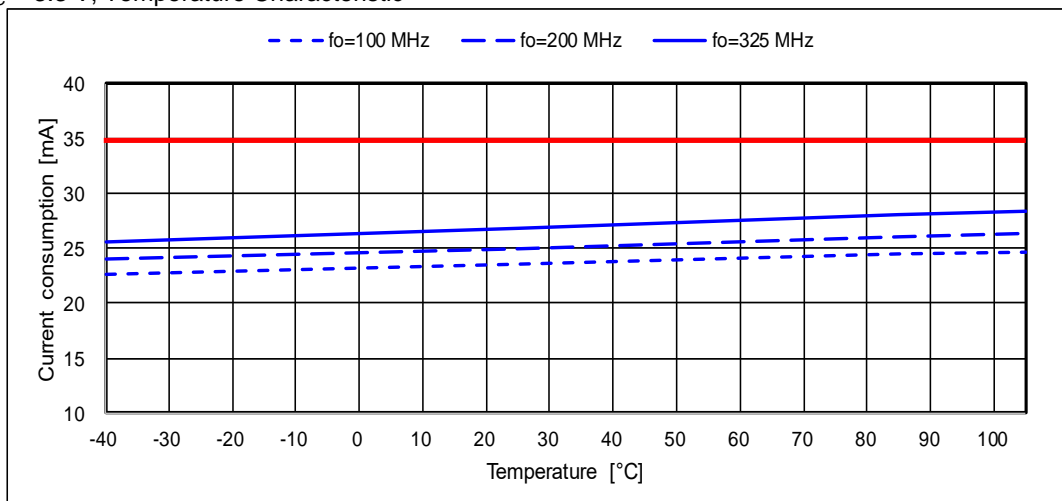
T<sub>use</sub> = +25 °C, Frequency DependencyV<sub>CC</sub> = 2.5 V, Temperature CharacteristicV<sub>CC</sub> = 3.3 V, Temperature Characteristic

## (7-3) Differential Output Rise / Fall Slew Rate Temperature Characteristic

fo = 100 MHz

Rise Slew Rate

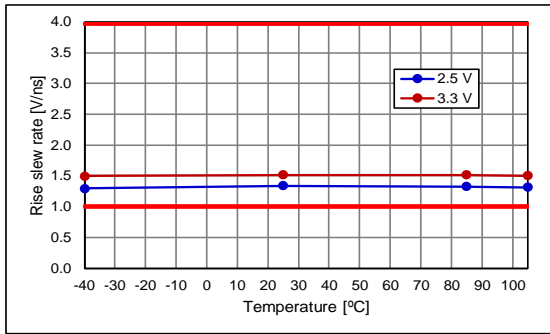

Fall Slew Rate

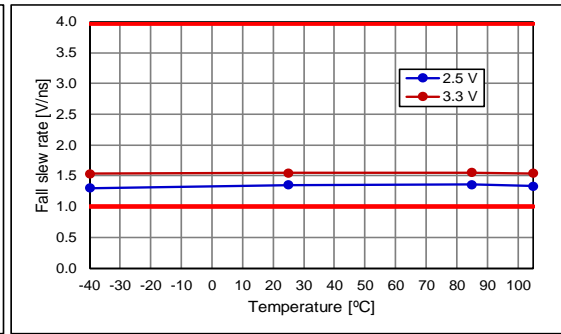

fo = 200 MHz

Rise Slew Rate

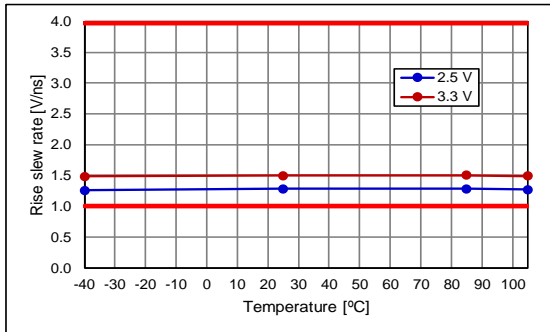

Fall Slew Rate

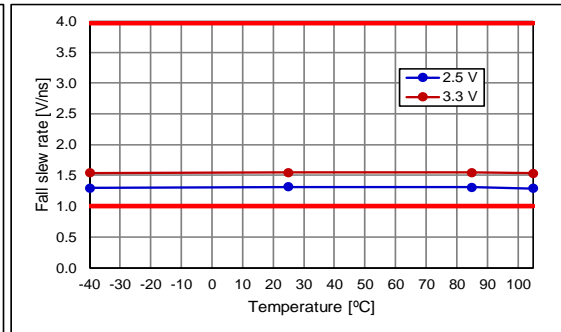

fo = 322.265625 MHz

Rise Slew Rate

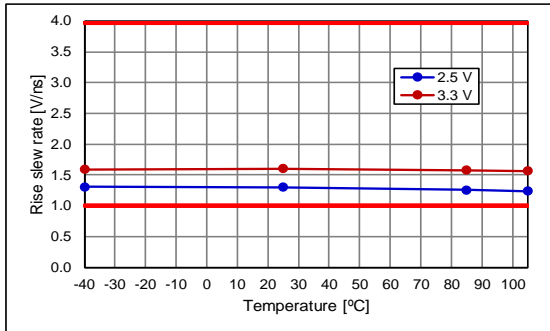

Fall Slew Rate

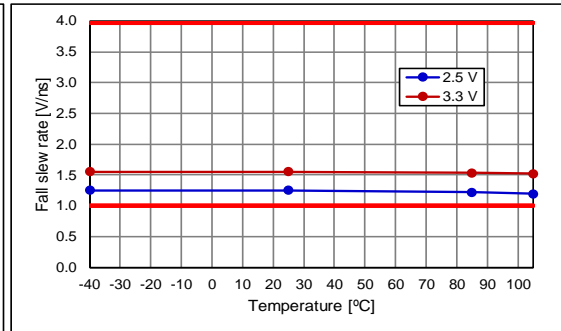

(7-4) Symmetry Temperature Characteristic

fo = 100 MHz

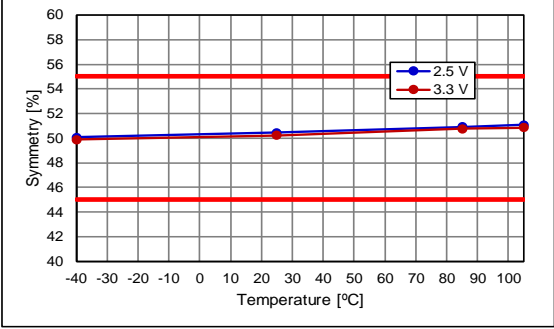

fo = 200 MHz

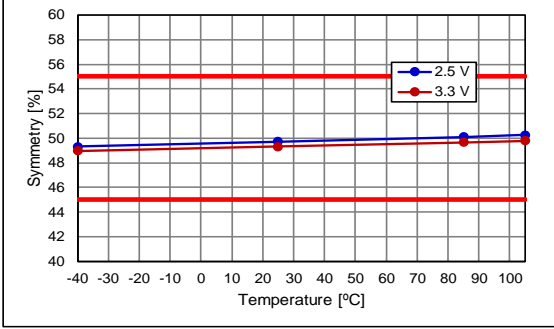

fo = 322.265625 MHz

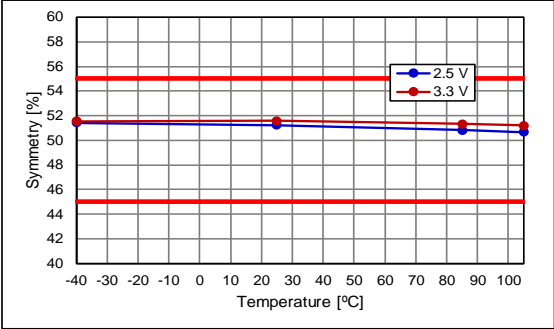

(7-5) Output Voltage Temperature Characteristic

V<sub>OH</sub>

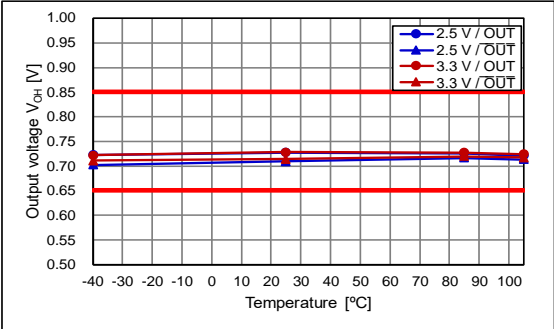

V<sub>OL</sub>

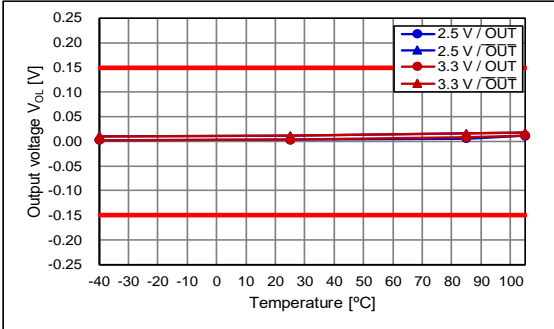



(7-6) Crossing Voltage Temperature Characteristic

fo = 100 MHz

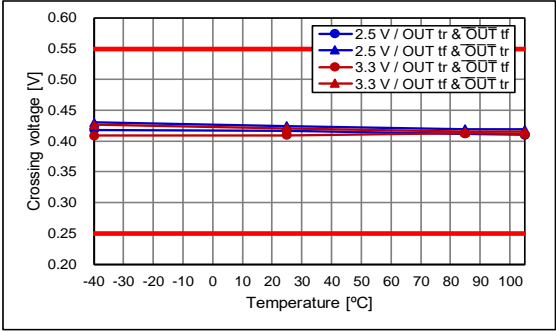

fo = 200 MHz

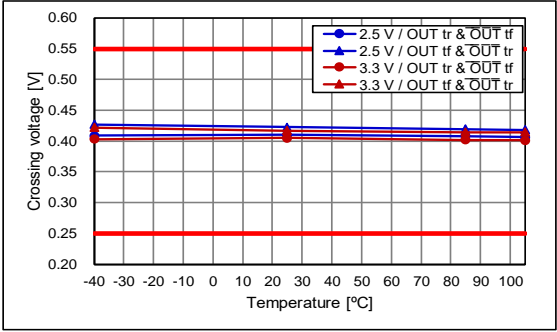

fo = 322.265625 MHz

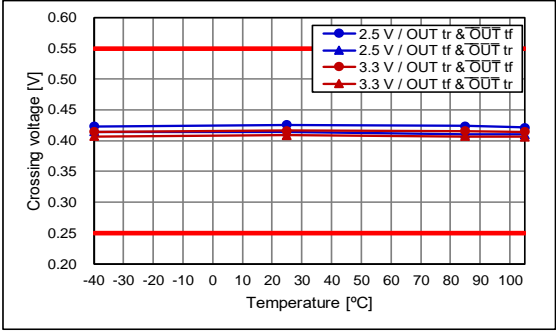

(7-7) Crossing Voltage Variation Temperature Characteristic

fo = 100 MHz

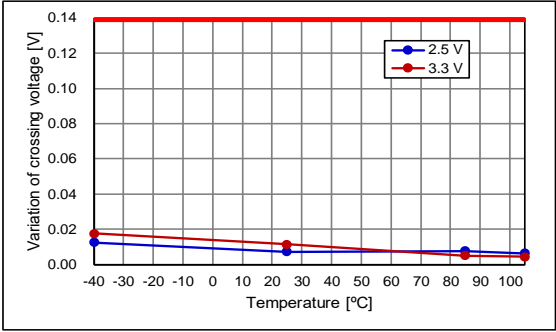

fo = 200 MHz

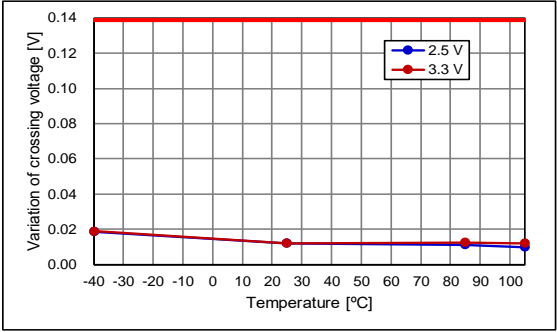

fo = 322.265625 MHz

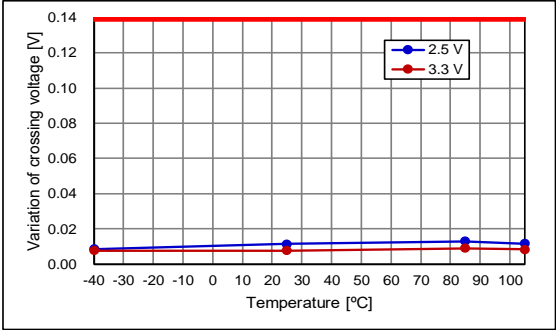

(7-8) Phase Noise and Phase Jitter

fo = 100 MHz, T<sub>use</sub> = +25 °C

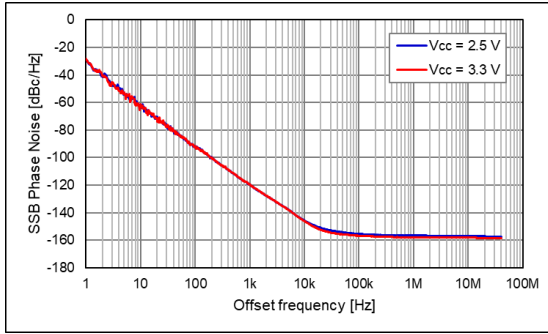

V <sub>CC</sub>	Phase Jitter*
2.5 V	126 fs
3.3 V	145 fs

\* Offset frequency: 12 kHz to 20 MHz

fo = 125 MHz, T<sub>use</sub> = +25 °C

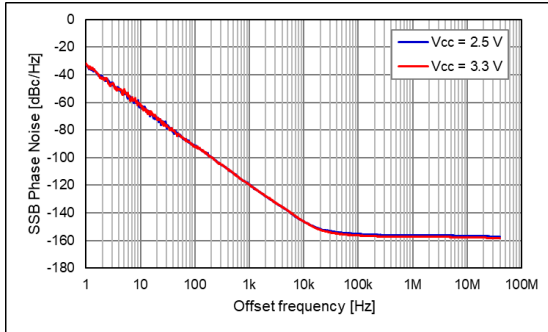

V <sub>CC</sub>	Phase Jitter*
2.5 V	121 fs
3.3 V	107 fs

\* Offset frequency: 12 kHz to 20 MHz

fo = 156.25 MHz, T<sub>use</sub> = +25 °C

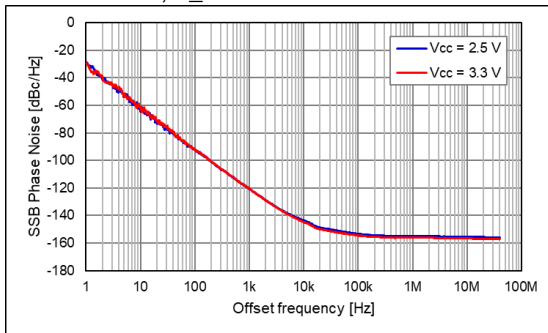

V <sub>CC</sub>	Phase Jitter*
2.5 V	110 fs
3.3 V	96 fs

\* Offset frequency: 12 kHz to 20 MHz

fo = 200 MHz, T<sub>use</sub> = +25 °C

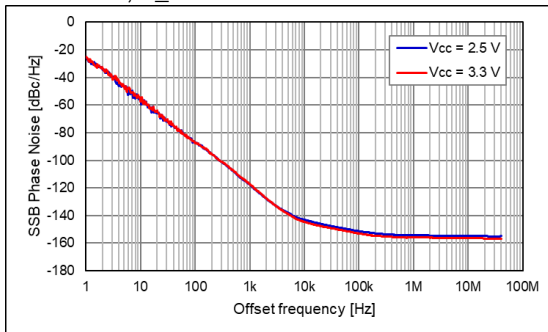

V <sub>CC</sub>	Phase Jitter*
2.5 V	94 fs
3.3 V	78 fs

\* Offset frequency: 12 kHz to 20 MHz

(7-8) Phase Noise and Phase Jitter [cont'd]

fo = 322.265625 MHz, T\_use = +25 °C

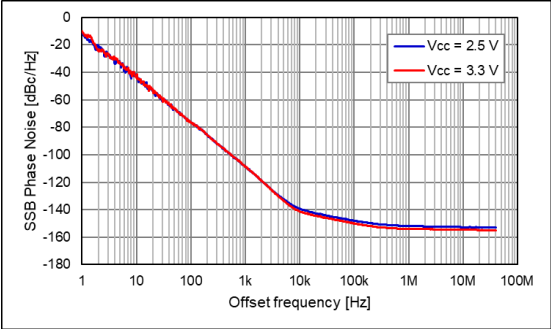

V <sub>CC</sub>	Phase Jitter*
2.5 V	75 fs
3.3 V	60 fs

\* Offset frequency: 12 kHz to 20 MHz

[ 8 ] Test Circuit

(8-1) Waveform Observation and Current Consumption Test Setup

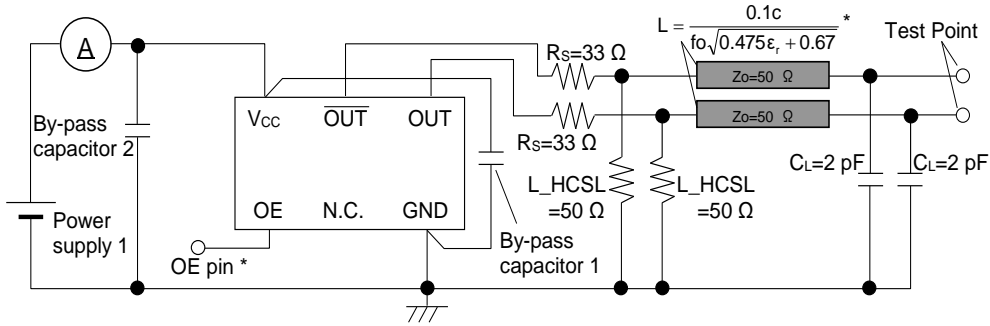

- \* Each output trace should be same length
- \* To measure Disable Current, OE terminal is connected to GND

(8-2) Conditions

(1) Oscilloscope

The bandwidth should be a minimum of 5 times wider than the measurement frequency  
 The probe ground should be placed closely to the test point and the lead length should be as short as possible

(2) A 0.1 μF and a 10 μF bypass capacitor should be connected between V<sub>CC</sub> and GND pins located close to the device

(3) Use a current meter with a low internal impedance

(4) Power Supply

Power supply startup time (0 %V<sub>CC</sub>→90 %V<sub>CC</sub>) should be more than 150 μs  
 Power supply impedance should be as low as possible

(8-3) Timing Chart

(1) Output Waveform and Level

OUT,  $\overline{\text{OUT}}$  Output Waveform

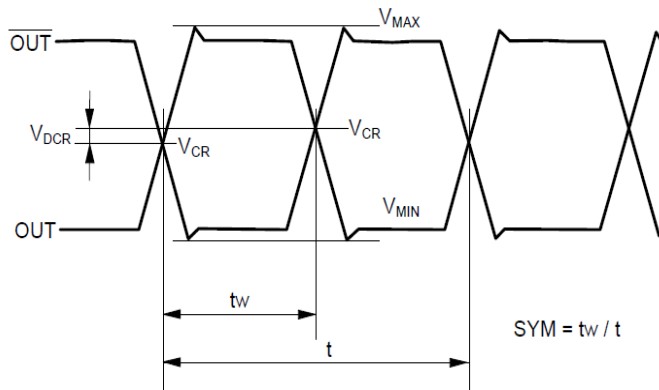

Differential Output Waveform

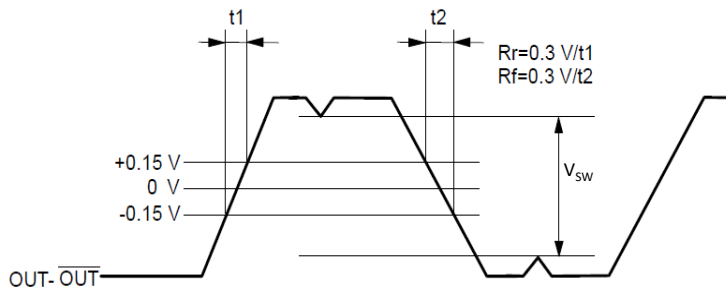

(8-3) Timing Chart (cont'd)  
 (2) Output Frequency Timing

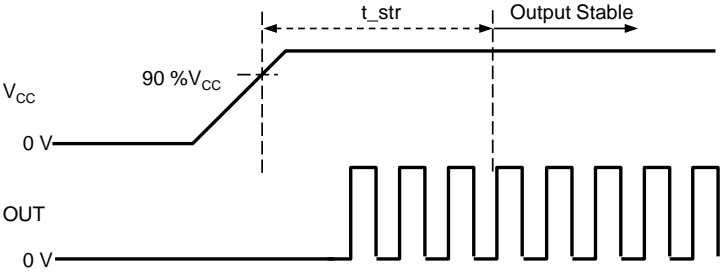

(3) OE Function and Timing

OE Terminal	Osc. Circuit	Output status
"H" or OPEN	Oscillation	Specified frequency is output: Enable
"L"	Oscillation	Output becomes high impedance: Disable

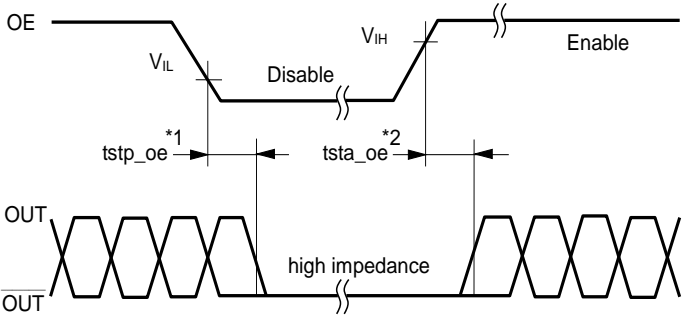

- \*1 The time from OE= $V_{IL}$  to output = disable (high impedance)
  - \*2 The time from OE= $V_{IH}$  to starting output
  - \* OE level should not exceed supply voltage when using the OE function
- Please note that during startup the OE voltage level should not exceed the supply voltage

[ 9 ] Outline Drawing and Recommended Footprint

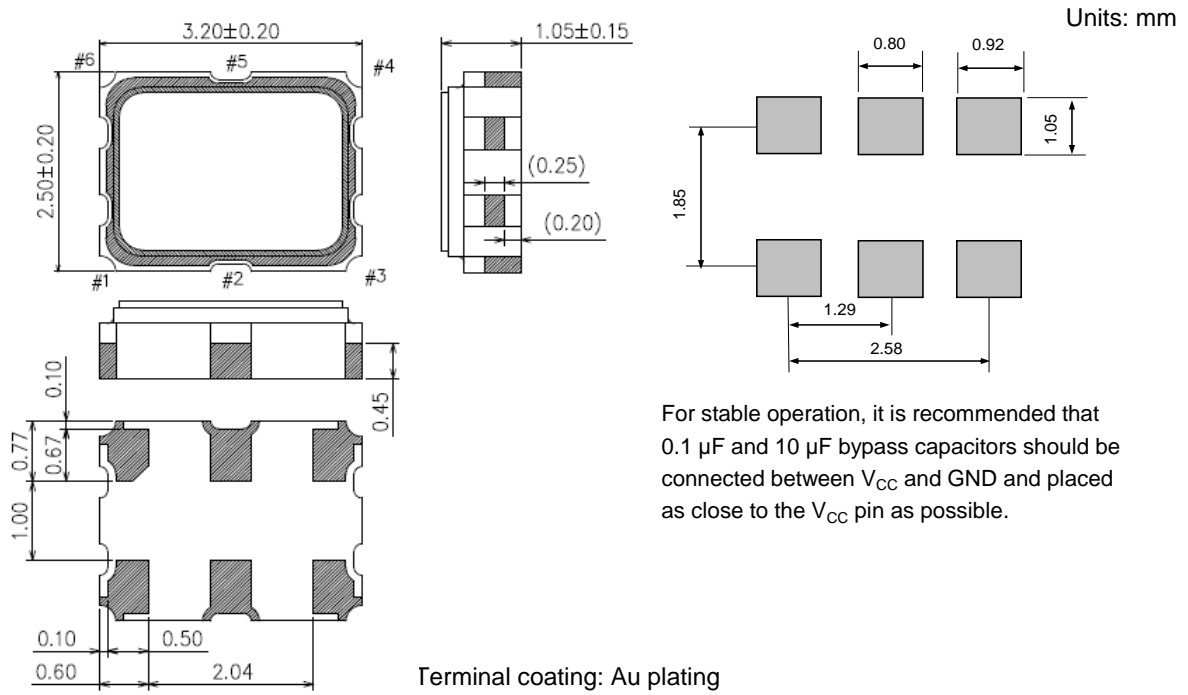

Reference weight Typ.: 25.6 mg

Terminal Assignment

Pin #	Connection	Function	
#1	OE	OE terminal / active high	
		OE function	Output
		"H" or OPEN	Specified frequency is output: Enable
		"L"	Output becomes high impedance: Disable
#2	NC	—	
#3	GND	GND terminal	
#4	OUT	Output terminal (Positive)	
#5	$\overline{\text{OUT}}$	Output terminal (Negative)	
#6	V <sub>CC</sub>	V <sub>CC</sub> terminal	

Marking

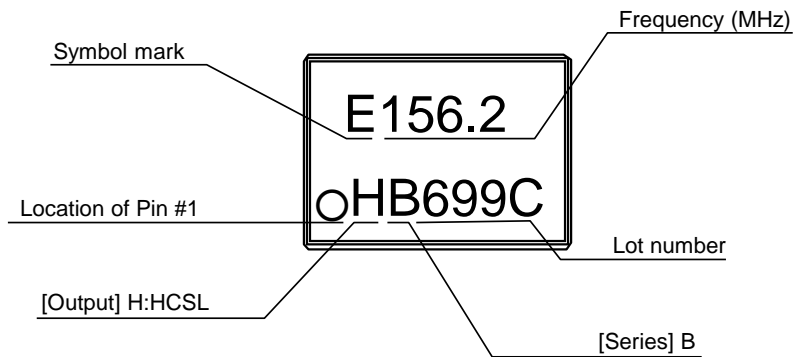

[ 10 ] Moisture Sensitivity Level

Parameter	Specification	Conditions
MSL	LEVEL 1	IPC/JEDEC J-STD-020D.1

[ 11 ] Reflow Profile

IPC/JEDEC J-STD-020D.1

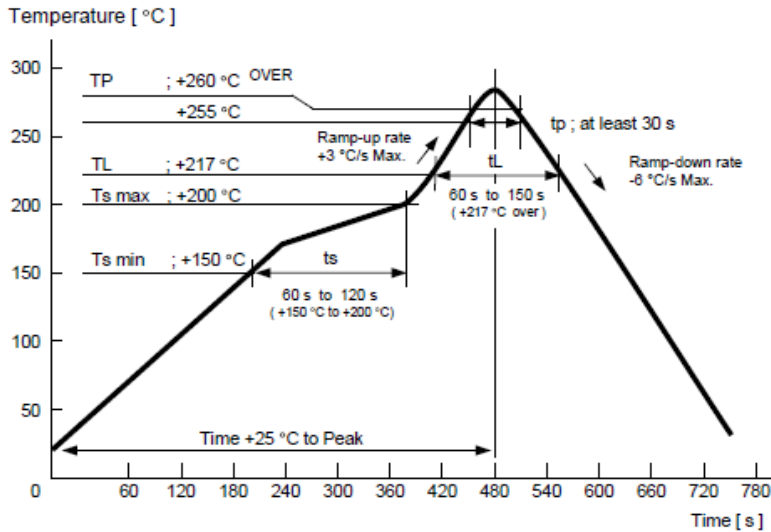

[ 12 ] Packing Information

(12-1) Packing Quantity

The last two digits of the Product Number (X1G005141xxxxxx) are a code that defines the packing quantity. The standard is "00" for a 2 000 pcs/Reel.

(12-2) Taping Specification

Subject to EIA-481, IEC-60286 and JIS C0806

(1) Tape Dimensions

Carrier Tape Material: PS (Polystyrene)

Top Tape Material: PET (Polyethylene Terephthalate) +PE (Polyethylene)

Units: mm

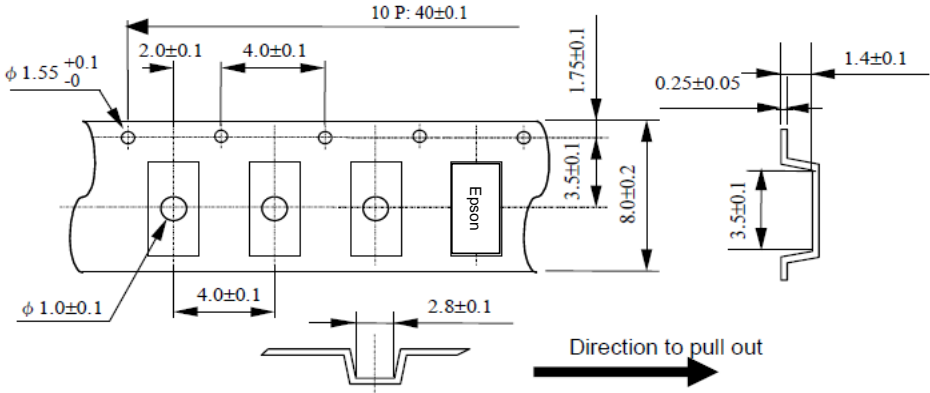

(2) Reel Dimensions

Center Material: PS (Polystyrene)

Reel Material: PS (Polystyrene)

Units: mm

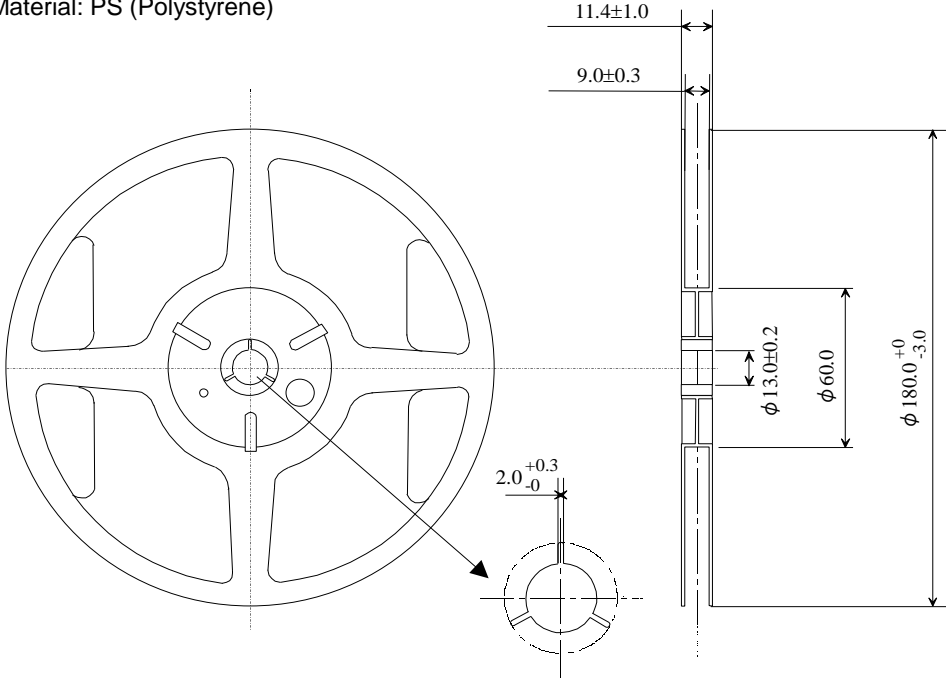

(12-3) Storage Environment

We recommend to keep less than +30 °C and 85 %RH of humidity in a packed condition, and to use it less than 6 months after delivery.



## [ 13 ] Handling Precautions

Prior to using this product, please carefully read the section entitled "Precautions" on our Web site (<https://www5.epsondevice.com/en/information/#precaution>) for instructions on how to handle and use the product properly to ensure optimal performance of the product in your equipment.

Before using the product under any conditions other than those specified therein, please consult with us to verify and confirm that the performance of the product will not be negatively affected by use under such conditions.

In addition to the foregoing precautions, in order to avoid the deteriorating performance of the product, we strongly recommend that you DO NOT use the product under ANY of the following conditions:

- (1) Do not expose this product to excessive mechanical shock or vibration.
- (2) This product can be damaged by mechanical shock during the soldering process depending on the equipment used, process conditions, and any impact forces experienced. Always follow appropriate procedures, particularly when changing the assembly process in any way and be sure to follow applicable process qualification standards before starting production.
- (3) These devices are sensitive to ESD, use appropriate precautions during handling, assembly, test, shipment, and installation.
- (4) The use of ultrasonic technology for cleaning, bonding, etc. can damage the Xtal unit inside this product. Please carefully check for this consideration before using ultrasonic equipment for volume production with this product.
- (5) Noise and ripple on the power supply may have undesirable effects on operation and cause degradation of phase noise characteristics. Evaluate the operation of this device with appropriate power supplies carefully before use.
- (6) When applying power, ensure that the supply voltage increases monotonically for proper operation. On power down, do not reapply power until the supplies, bypass capacitors, and any bulk capacitors are completely discharged since that may cause the unit to malfunction.
- (7) Aging specifications are estimated from environmental reliability tests and expected frequency variation over time. They do not provide a guarantee of aging over the product lifecycle.
- (8) The metal cap on top of the device is directly connected to the GND terminal. Take necessary precautions to prevent any conductor not at ground potential from contacting the cap as that could cause a short circuit to GND.
- (9) To avoid any issues due to interference of other signal lines, please take care not to place signal lines near the product as this may have an adverse affect on the performance of the product.
- (10) A bypass capacitor of the recommended value(s) must be connected between the  $V_{CC}$  and GND terminals of the product. Whenever possible, mount the capacitor(s) on the same side of the PCB and as close to the product as possible to keep the routing traces short.
- (11) Power supply connections to  $V_{CC}$  and GND pins should be routed as thick as possible while keeping the high frequency impedance low in order to get the best performance.
- (12) The use of a filter or similar element in series with the power supply connections to protect from electromagnetic radiation noise may increase the high frequency impedance of the power supply line and may cause the oscillator to not operate properly. Please verify the design to ensure sufficient operational margin prior to use.
- (13) Keep PCB routing from the output terminal(s) to the load as short as possible for best performance.
- (14) The Enable (OE) input terminal is high impedance and so susceptible to noise. Connect it to a low impedance source when used and when not used it is recommended to connect it to  $V_{CC}$  for active high inputs and GND for active low inputs.
- (15) Do not short the output to GND as that will damage the product. Always use with an appropriate load resistor connected.
- (16) This product should be reflowed no more than 3 times.  
If rework is needed after reflow, please correct it with a soldering iron with the tip set for a temperature of +350 °C or less and only contact each terminal once and for no more than 5 seconds.  
If this product is mounted on the bottom of the board during a reflow please check that it soldered down properly afterwards.
- (17) Product failures during the warranty period only apply when the product is used according to the recommended operating conditions described in the specifications. Products that have been opened for analysis or damaged will not be covered.  
It is recommended to store and use in normal temperature and humidity environments described in the specifications to ensure frequency accuracy and prevent moisture condensation. If the product is stored for more than one year, please confirm the pin solderability prior to use.
- (18) If the oscillation circuit is exposed to condensation, the frequency may change or oscillation may stop. Do not use in any conditions where condensation occurs.
- (19) Do not store or use the product in an environment where it can be exposed to chemical substances that are corrosive to metal or plastics such as salt water, organic solvents, chemical gasses, etc. Do not use the product when it is exposed to sunlight, dust, corrosive gasses, or other materials for long periods of time.
- (20) When using water-soluble solder flux make sure to completely remove the flux residue after soldering.  
Pay particular attention when the residues contain active halogens which will negatively affect the product and its performance.
- (21) Terminals on the side of the product are internally connected to the IC, be careful not to cause short-circuits or reduce the insulation resistance of them in any way.
- (22) Should any customer use the product in any manner contrary to the precautions and/or advice herein, such use shall be done at the customer's own risk.

## [Availability of mounting conditions]

Reflow on the board	Available
Reflow under the board	The parts may fail. Please judge whether it is possible to implement.
Soldering pot/bath (Dip soldering system, Flow soldering system)	<b>Not Available</b>
Soldering iron	Available

**PROMOTION OF ENVIRONMENTAL MANAGEMENT SYSTEM  
CONFORMING TO INTERNATIONAL STANDARDS**

At Seiko Epson, all environmental initiatives operate under the Plan-Do-Check-Action (PDCA) cycle designed to achieve continuous improvements. The environmental management system (EMS) operates under the ISO 14001 environmental management standard.

All of our major manufacturing and non-manufacturing sites, in Japan and overseas, completed the acquisition of ISO 14001 certification.



ISO 14000 is an international standard for environmental management that was established by the International Standards Organization in 1996 against the background of growing concern regarding global warming, destruction of the ozone layer, and global deforestation.

**WORKING FOR HIGH QUALITY**

In order provide high quality and reliable products and services than meet customer needs, Seiko Epson made early efforts towards obtaining ISO9000 series certification and has acquired ISO9001 for all business establishments in Japan and abroad. We have also acquired IATF 16949 certification that is requested strongly by major manufacturers as standard.

IATF 16949 is the international standard that added the sector-specific supplemental requirements for automotive industry based on ISO9001.

■ Explanation of marks used in this datasheet

	<p>●Pb free.</p>
	<p>●Complies with EU RoHS directive. *About the products without the Pb-free mark. Contains Pb in products exempted by EU RoHS directive (Contains Pb in sealing glass, high melting temperature type solder or other)</p>

**NOTICE: PLEASE READ CAREFULLY BELOW BEFORE THE USE OF THIS DOCUMENT ©Seiko Epson Corporation 2020**

- The content of this document is subject to change without notice. Before purchasing or using Epson products, please contact with sales representative of Seiko Epson Corporation ("Epson") for the latest information and be always sure to check the latest information published on Epson's official web sites and resources.
- This document may not be copied, reproduced, or used for any other purposes, in whole or in part, without Epson's prior consent.
- Information provided in this document including, but not limited to application circuits, programs and usage, is for reference purpose only. Epson makes no guarantees against any infringements or damages to any third parties' intellectual property rights or any other rights resulting from the information. This document does not grant you any licenses, any intellectual property rights or any other rights with respect to Epson products owned by Epson or any third parties.
- Using Epson products, you shall be responsible for safe design in your products; that is, your hardware, software, and/or systems shall be designed enough to prevent any critical harm or damages to life, health or property, even if any malfunction or failure might be caused by Epson products. In designing your products with Epson products, please be sure to check and comply with the latest information regarding Epson products (including, but not limited to this document, specifications, data sheets, manuals, and Epson's web site). Using technical contents such as product data, graphic and chart, and technical information, including programs, algorithms and application circuit examples under this document, you shall evaluate your products thoroughly both in stand-alone basis and within your overall systems. You shall be solely responsible for deciding whether to adopt/use Epson products with your products.
- Epson has prepared this document carefully to be accurate and dependable, but Epson does not guarantee that the information is always accurate and complete. Epson assumes no responsibility for any damages you incurred due to any misinformation in this document.
- No dismantling, analysis, reverse engineering, modification, alteration, adaptation, reproduction, etc., of Epson products is allowed.
- Epson products have been designed, developed and manufactured to be used in general electronic applications and specifically requires particular quality or extremely high reliability in order to refrain from causing any malfunction or failure leading to critical harm to life and health, serious property damage, or severe impact on society, including, but not limited to listed below ("Specific Purpose"). Therefore, you are strongly advised to use Epson products only for the Anticipated Purpose. Should you desire to purchase and use Epson products for Specific Purpose, Epson makes no warranty and disclaims with respect to Epson products, whether express or implied, including without limitation any implied warranty of merchantability or fitness for any Specific Purpose. Please be sure to contact our sales representative in advance, if you desire Epson products for Specific Purpose:  
Space equipment (artificial satellites, rockets, etc.)/ Transportation vehicles and their control equipment (automobiles, aircraft, trains, ships, etc.) / Medical equipment/ Relay equipment to be placed on sea floor/ Power station control equipment / Disaster or crime prevention equipment/Traffic control equipment/ Financial equipment  
Other applications requiring similar levels of reliability as the above
- Epson products listed in this document and our associated technologies shall not be used in any equipment or systems that laws and regulations in Japan or any other countries prohibit to manufacture, use or sell. Furthermore, Epson products and our associated technologies shall not be used for the purposes of military weapons development (e.g. mass destruction weapons), military use, or any other military applications. If exporting Epson products or our associated technologies, please be sure to comply with the Foreign Exchange and Foreign Trade Control Act in Japan, Export Administration Regulations in the U.S.A (EAR) and other export-related laws and regulations in Japan and any other countries and to follow their required procedures.
- Epson assumes no responsibility for any damages (whether direct or indirect) caused by or in relation with your non-compliance with the terms and conditions in this document or for any damages (whether direct or indirect) incurred by any third party that you give, transfer or assign Epson products.
- For more details or other concerns about this document, please contact our sales representative.
- Company names and product names listed in this document are trademarks or registered trademarks of their respective companies.